

## CAPACIDADE DE CARGA E DIMENSÃO TOTAL

Capacidad de carga y dimensión total  
Load capacity and total dimension

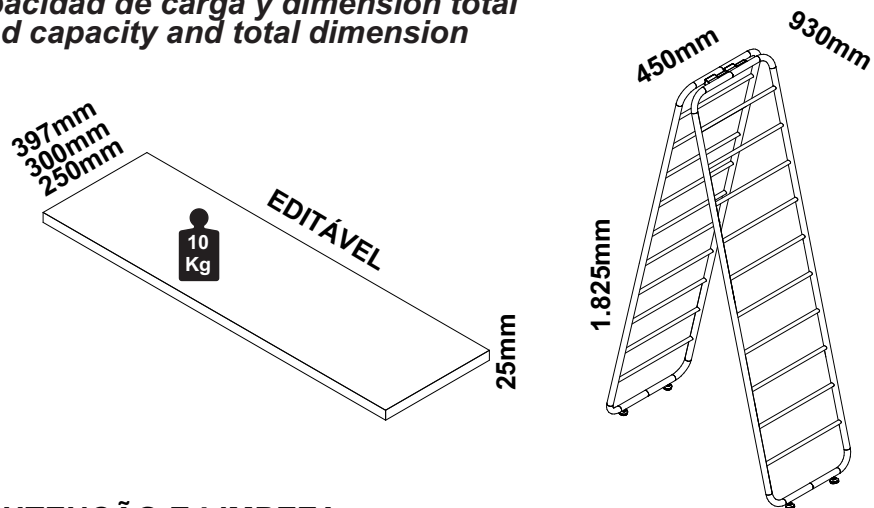

## MANUTENÇÃO E LIMPEZA

- Pano levemente umedecido com água, seguido de pano seco.
- Nunca utilizar produtos químicos ou abrasivos.
- **Mantenimiento y Limpieza:** Paño ligeiramente humedecido con agua, seguido de un paño seco.
- No utilice nunca productos químicos o abrasivos.
- **Maintenance and Cleaning:** Cloth slightly moistened with water, followed by cloth seo.
- Never use chemicals or abrasives.

## RECOMENDAÇÕES

- Siga atentamente todas as instruções de montagem;
- Monte seu produto no local ou próximo de onde será colocado. Movimentações do produto já montado podem avariá-lo;
- Faça a montagem em uma superfície limpa e plana. Aconselhamos usar a própria embalagem de papelão e plástico para forrar o chão;
- Verifique se as quantidades de peças e acessórios estão de acordo com o Manual;
- Compare atentamente os furos de cada peça com a ilustração do manual
- Se o produto necessitar fixação na parede, tenha cuidado para não atingir fios e canos ao furar a parede;
- É responsabilidade do montador seguir as instruções do Manual de Montagem que são fundamentais para a estruturação do produto.

### Recommendations

- Carefully follow all assembly instructions;
- Assemble your product at or near where it will be placed. Movements of the product already assembled may damage it;
- Mount on a clean, flat surface. We advise you to use the cardboard and plastic packaging itself to cover the floor;
- Check that the quantities of parts and accessories are in accordance with the manual;
- Carefully compare the holes in each part with the illustration in the manual;
- If the product needs to be fixed to the wall, be careful not to reach wires and pipes when drilling into the wall;
- It is the assembler's responsibility to follow the instructions in the Assembly Manual, which are fundamental for structuring the product.

### Recomendaciones

- Siga cuidadosamente todas las instrucciones de montaje;
- Ensamble su producto en o cerca de donde se colocará. Los movimientos del producto ya ensamblado pueden dañarlo;
- Montar sobre una superficie limpia y plana. Le recomendamos que utilice el embalaje de cartón y plástico para cubrir el piso;
- Compruebe que las cantidades de piezas y accesorios están de acuerdo con el manual;
- Compare cuidadosamente los agujeros en cada parte con la ilustración en el manual;
- Si el producto necesita ser fijado a la pared, tenga cuidado de no alcanzar cables y tuberías al perforar la pared;
- Es responsabilidad del ensamblador seguir las instrucciones del Manual de ensamblaje, que son fundamentales para estructurar el producto.

## INSTRUÇÕES DE MONTAGEM ASSEMBLY INSTRUCTIONS INSTRUCCIONES DE MONTAJE

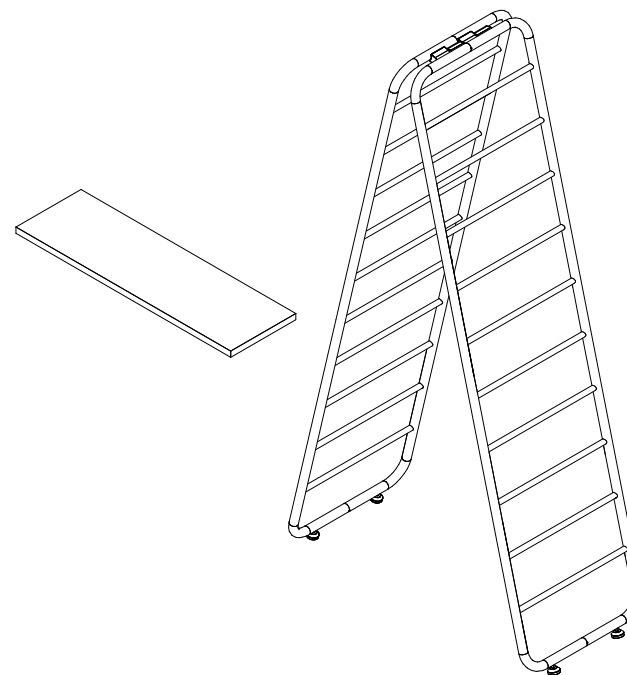

São necessários:  
Son necesarios:  
Are necessary:



\*Parafusadeira  
Atornillador  
Screwdriver



\*Martelo  
Martillo  
Hammer



Chave Allen  
llave allen  
Allen Key



\*\*Trena  
Cinta métrica  
Measuring tape



10min



2 Pessoas  
Persona  
Person

\*\* Facilita a montagem / Facilita el montaje / Facilitates mounting.  
\*\* Para identificar as peças / Para identificar las partes / To identify the parts.

REF. # SPE9018

 **Gebbwork**

MOBILIÁRIO  
PARA ESCRITÓRIO

GEBB Work Ind. de Móveis Ltda.  
Rua Felix Roman, 190  
São Valentin

95709-170 - Bento Gonçalves - RS - Brasil  
Fone: (0XX54) 3454-1105 - (0XX54) 3453-1407  
Phone: (0XX54) 3454-1105 - (0XX54) 3453-1407

E-mail: pedidos@gebbwork.com.br

www.gebbwork.com.br

WhatsApp: +55 54 99177-8324

REV.: 00 - 26/04/2025

01/12

# LISTA DE PEÇAS

Parts Identification

Lista de Piezas

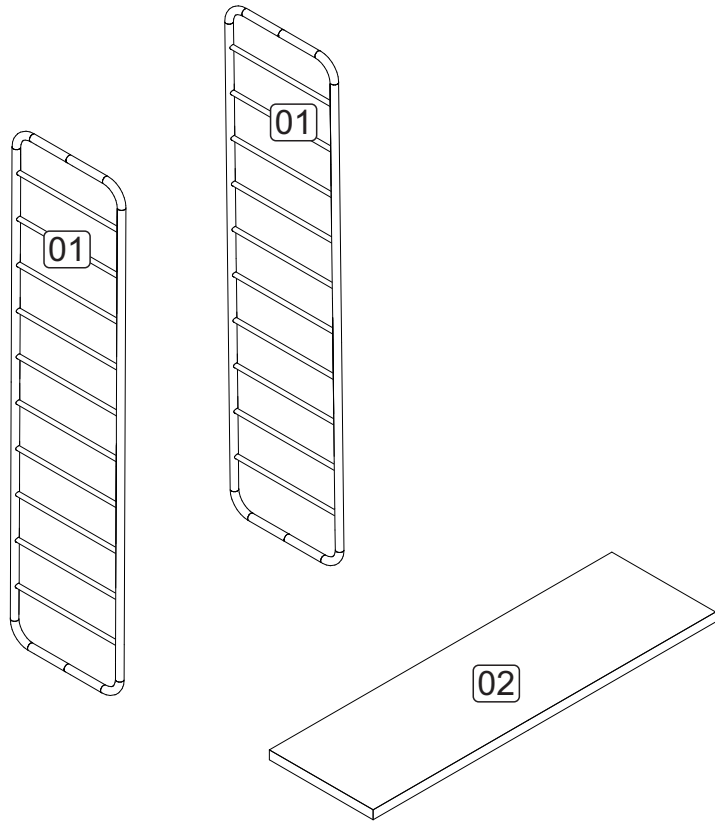

01 - DIVISÓRIA FRAME  
02 - PRATELEIRA

# Acessórios

Accessories

Accesorios

L17 - SAPATA ARTICULADA  
ROSCA 5/16 (35MM) **4x**

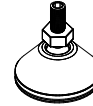

G10 - SUPORTE PAREDE  
P/DOBRADIÇA **1x**

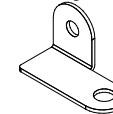

G9 - DOBRADIÇA RETA **1x**

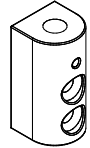

G6 - DOBRADIÇA CURVA **5x**



G7 - PARAF. M4 ALLEN S.C. **6x**



A29 - PARAF. 4,2x38 CF  
BROCANTE **2x**

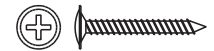

G8 - PINO GUIA DOBRADIÇA **3x**



A15 - PARAF. 4,8x38 CP **10x**



K1 - ABRAÇADEIRA **4x**



B20 - BUCHA NYLON  
UX 8x50 **1x**



A24 - PARAF. 5,0x60 CF **1x**



A8 - PARAF. 4,0x14 CP **20x**



M4 - CHAPA P/CONEXÃO  
04 FUROS **4x**

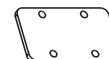

## 2 MONTAGEM DIVISÓRIAS

Armado  
Assembly

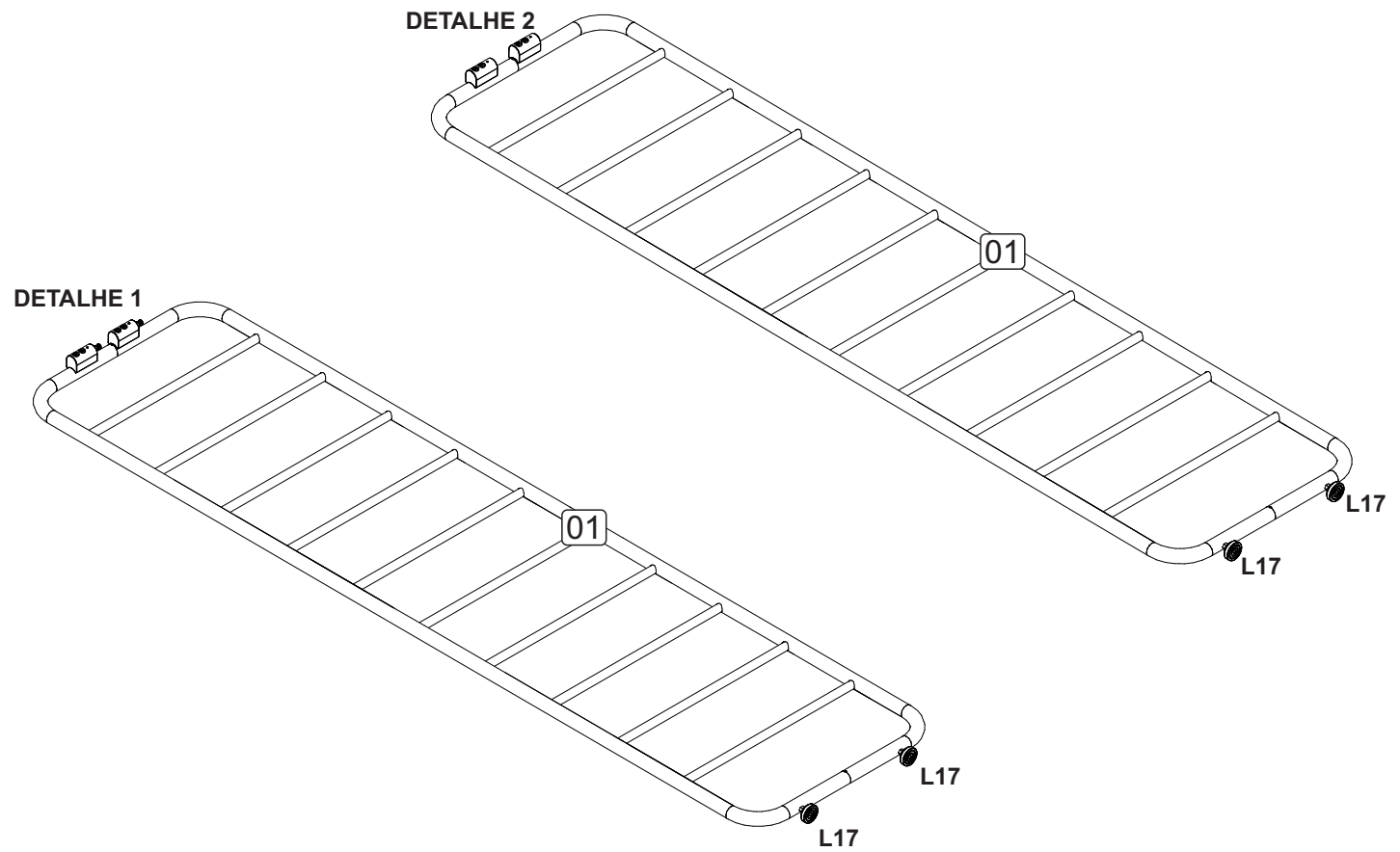
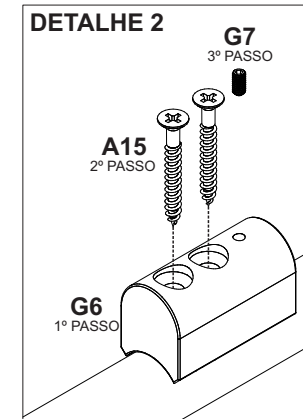
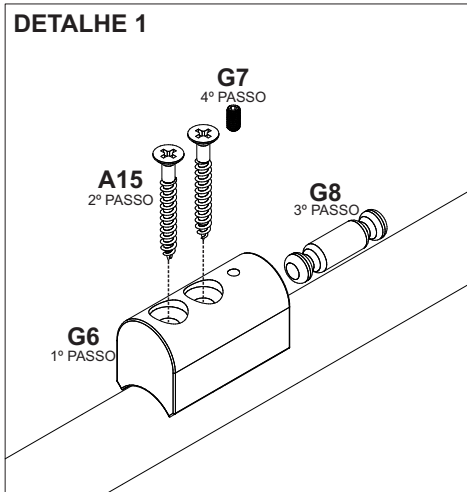

Acessórios utilizados:  
Accesorios utilizados:  
Accessories used:



L17 - 4x



G6 - 4x



G7 - 4x



G8 - 4x



A15 - 8x

### 3 MONTAGEM DIVISÓRIAS

Armado  
Assembly

Encaixar uma divisória na outra através das divisórias.

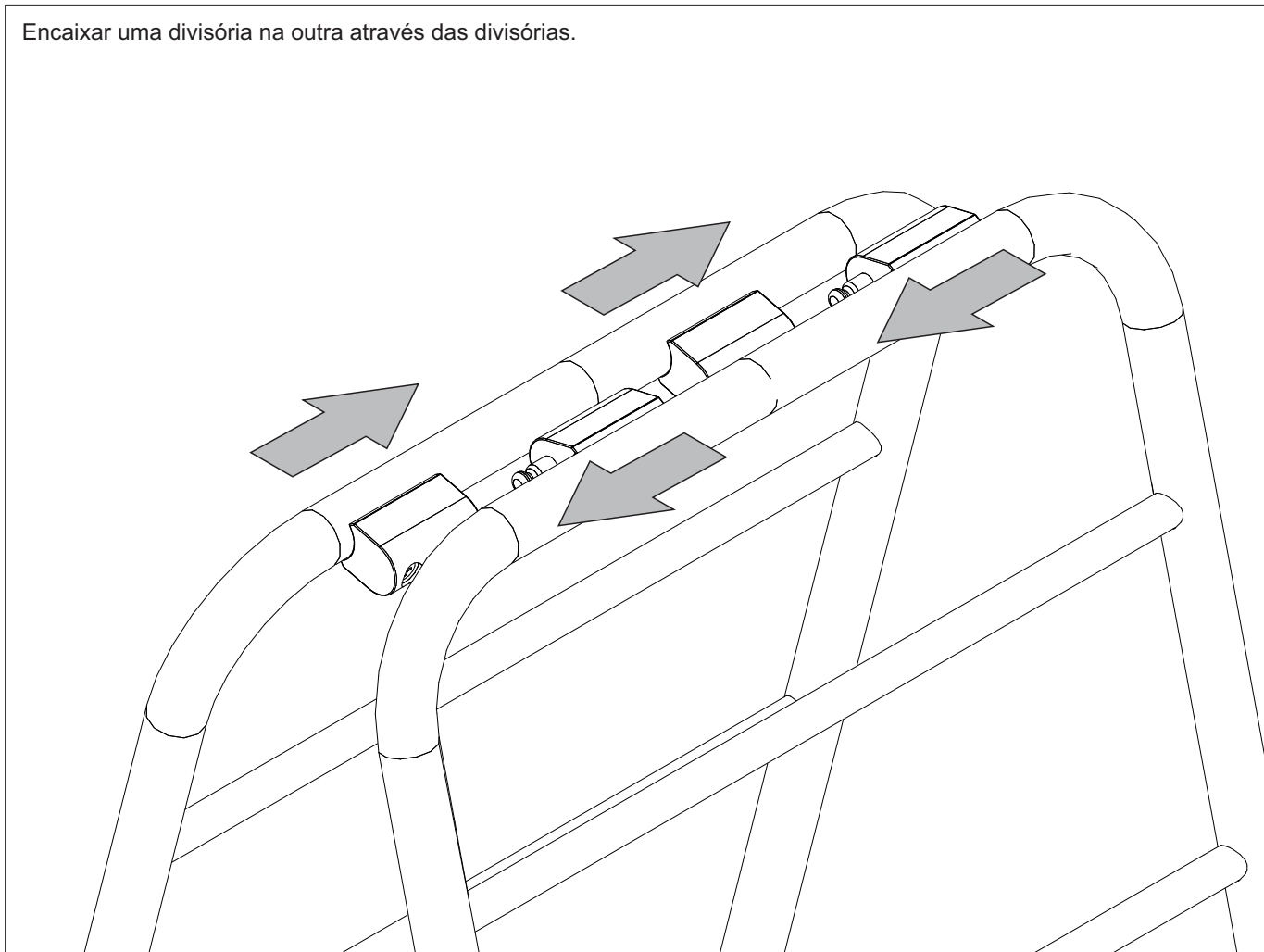

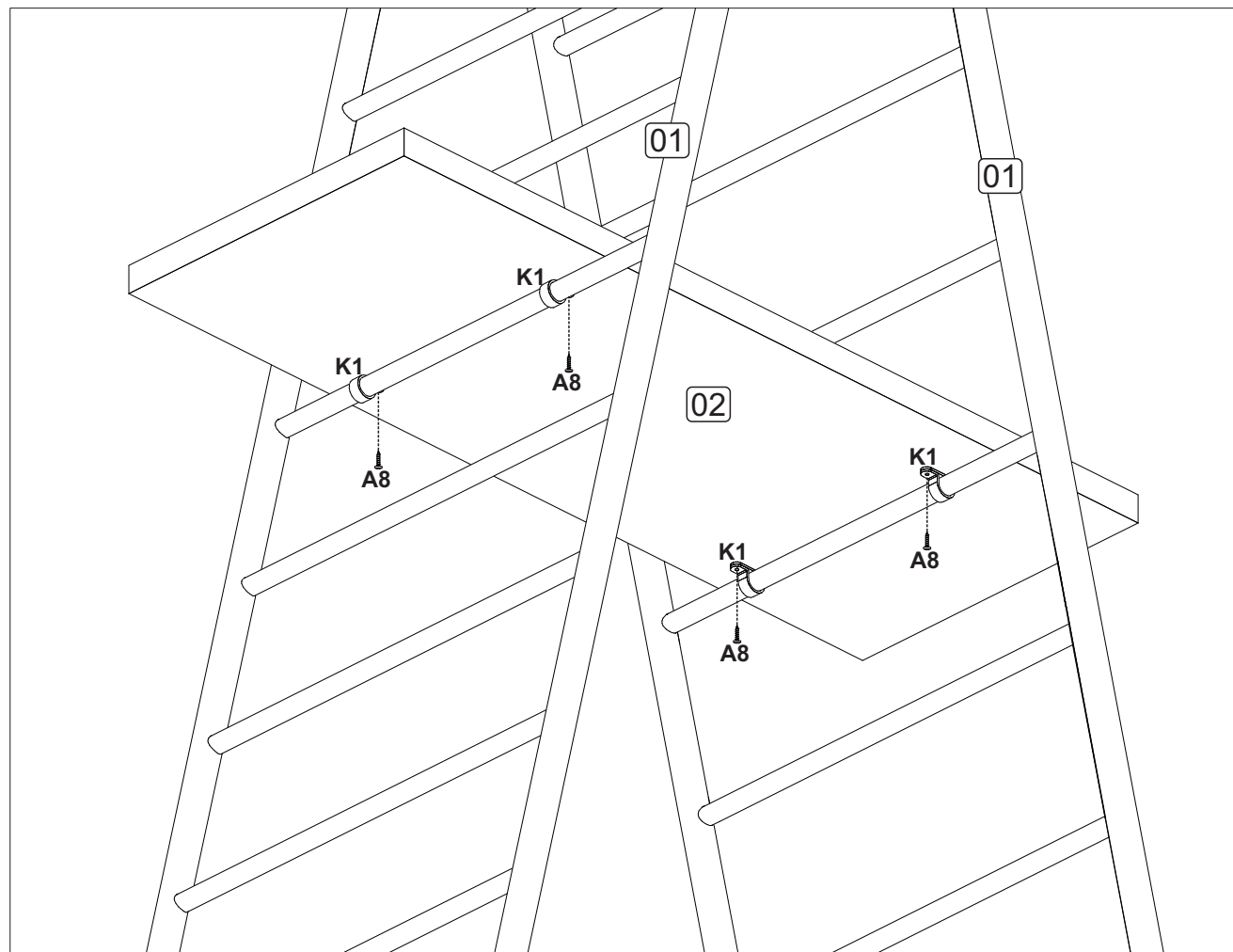
**4****MONTAGEM PRATELEIRA***Armado  
Assembly***Acessórios utilizados:***Accesorios utilizados:  
Accessories used:*

A8 - 4x



K1 - 4x

# 5 MONTAGEM PRATELEIRA CENTRAL

Armado  
Assembly

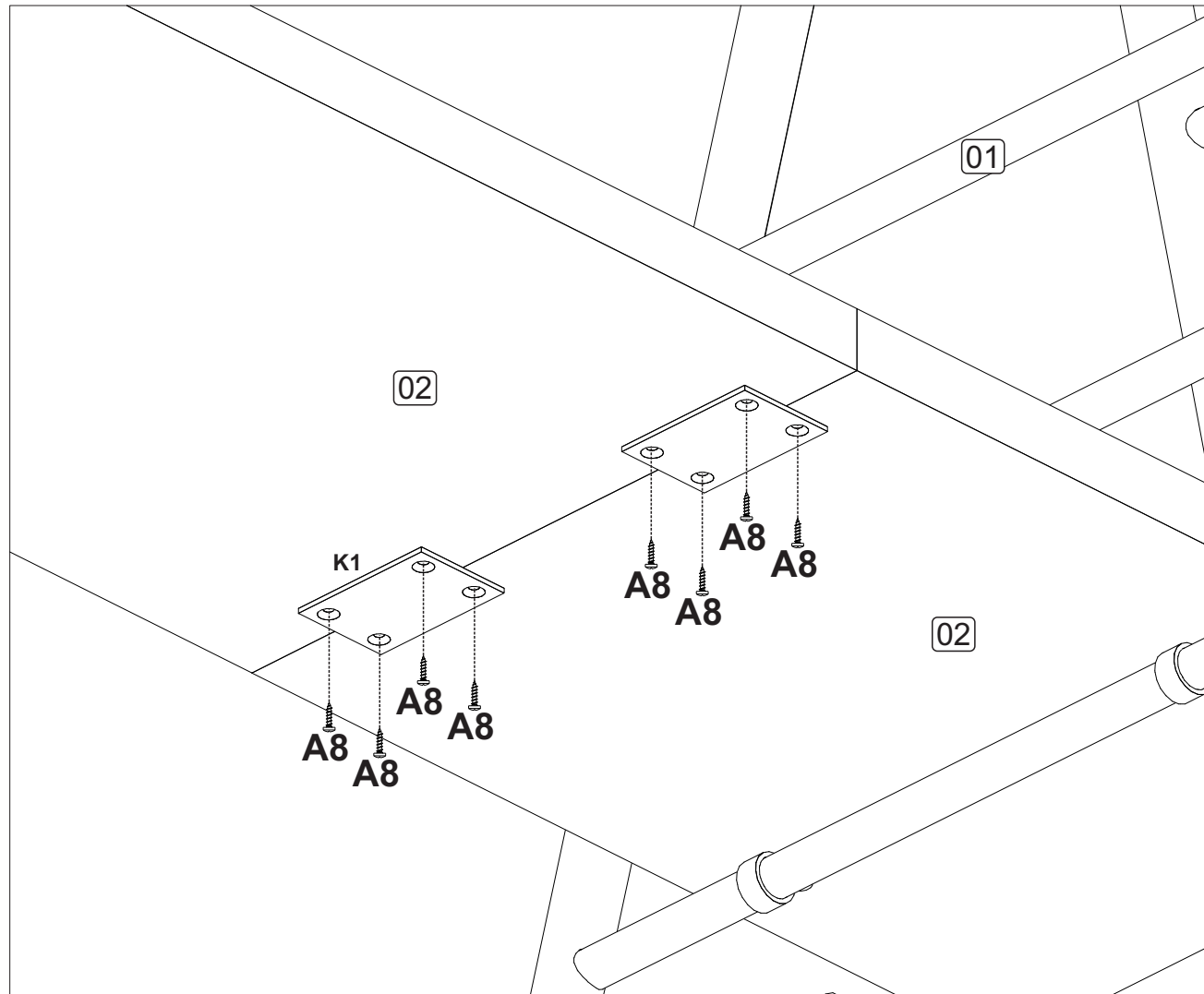

**Acessórios utilizados:**  
Accesorios utilizados:  
Accessories used:



A8 - 16x

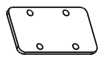

M4 - 4x

## 6 MONTAGEM SISTEMA ANTI-TOMBAMENTO

Armado  
Assembly

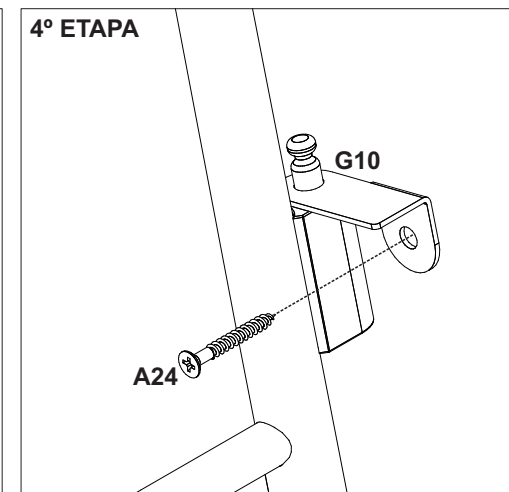
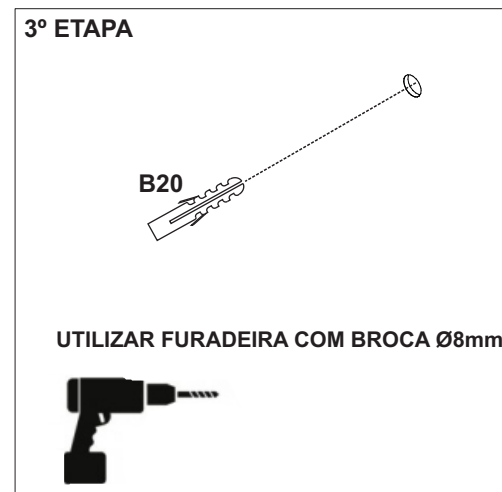
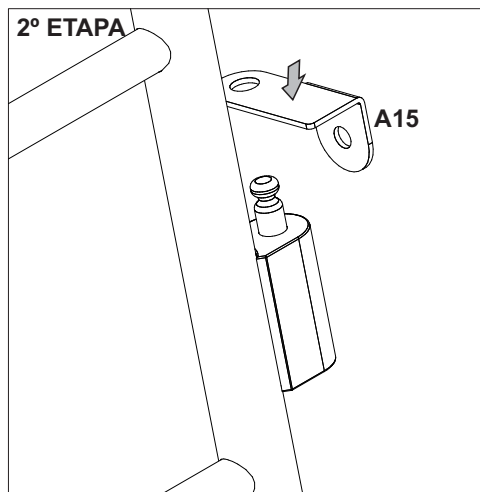
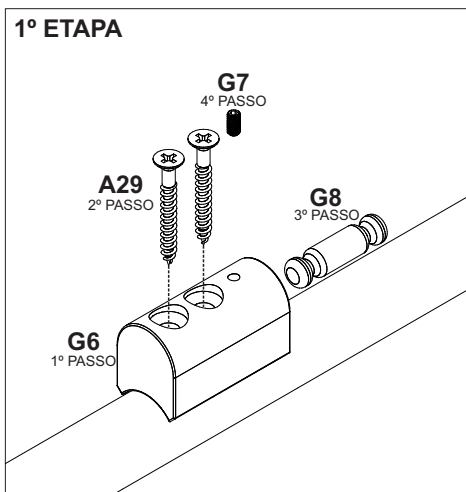

**IMPORTANTE: EM DIVISÓRIAS DE MDP SUBSTITUIR  
A DOBRADIÇA CURVA G6 POR DOBRADIÇA RETA G9.  
BEM COMO SUBSTITUIR OS PARAFUSOS A29 PELOS  
PARAFUSOS A15.**

**Acessórios utilizados:**  
Accesorios utilizados:  
Accessories used:



G10 - 1x



G9 - 1x



G6 - 1x



G7 - 1x



A29 - 2x



G8 - 1x



B20 - 1x



A24 - 2x



A15 - 2x

# 7 SPE1945 - DIVISÓRIA MODELO A FRAME PARA PRATELEIRAS

PROFUNDIDADE DAS PRATELEIRAS

SPE2525  
SPE2526

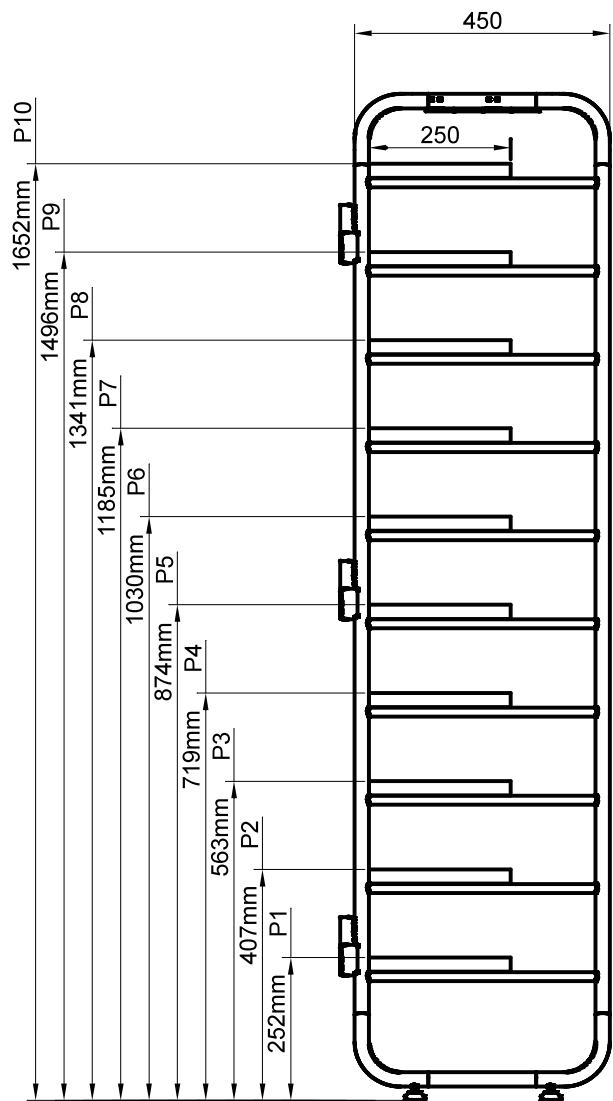

SPE2530  
SPE2531

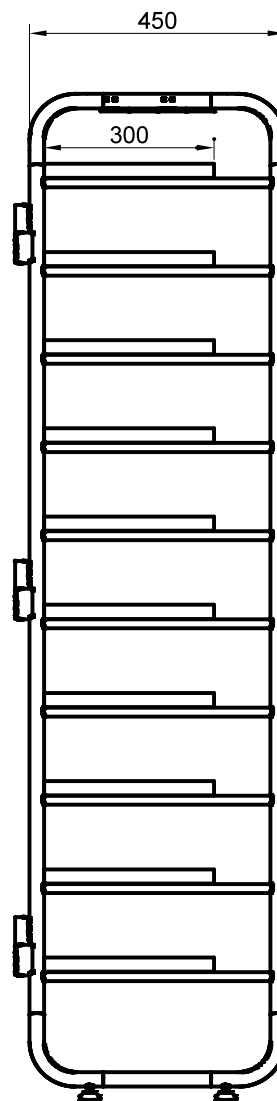

SPE2540  
SPE2541

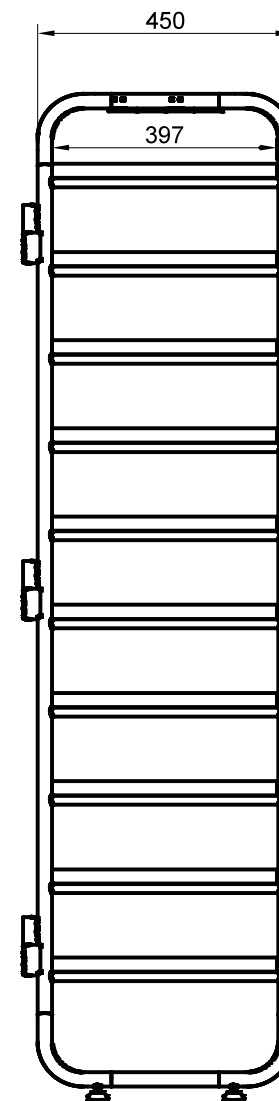

# 8 SPE1945 - DIVISÓRIA MODELO A FRAME PARA PRATELEIRAS

## LARGURA DAS PRATELEIRAS

SPE1945 + SPE2525  
UM MÓDULO SPE2530  
SPE2540

SPE1945 + SPE2525  
DOIS MÓDULOS SPE2530  
SPE2540

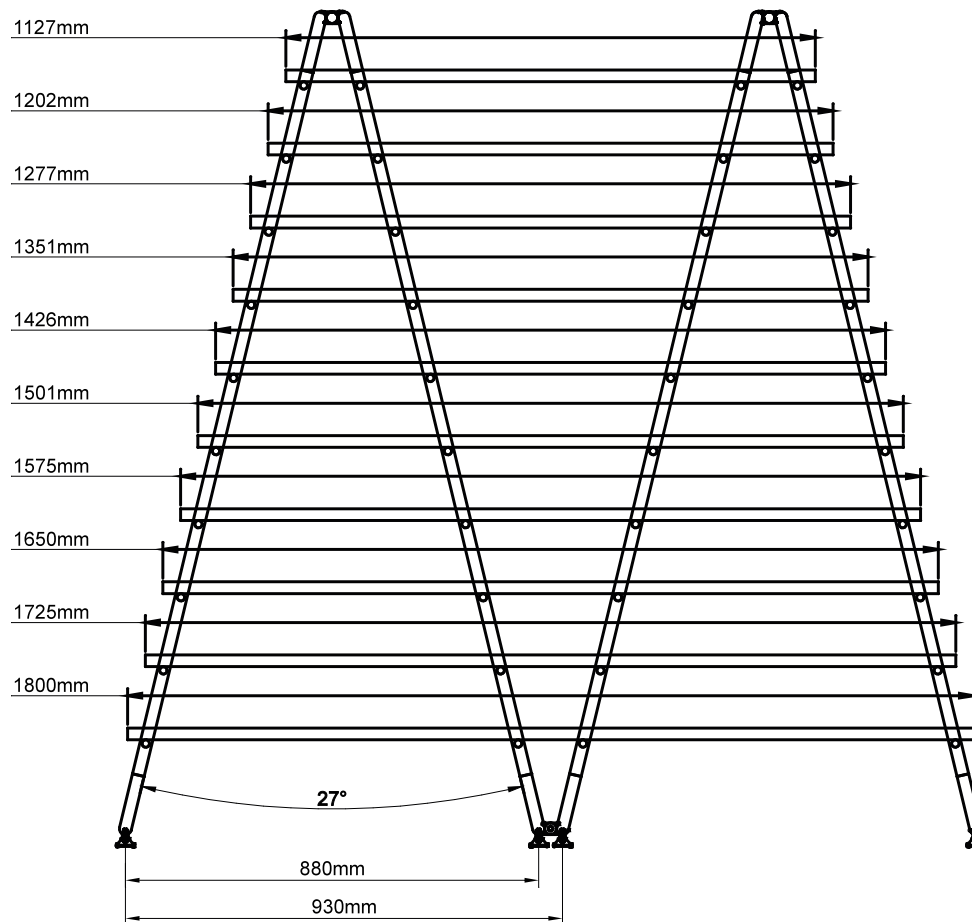
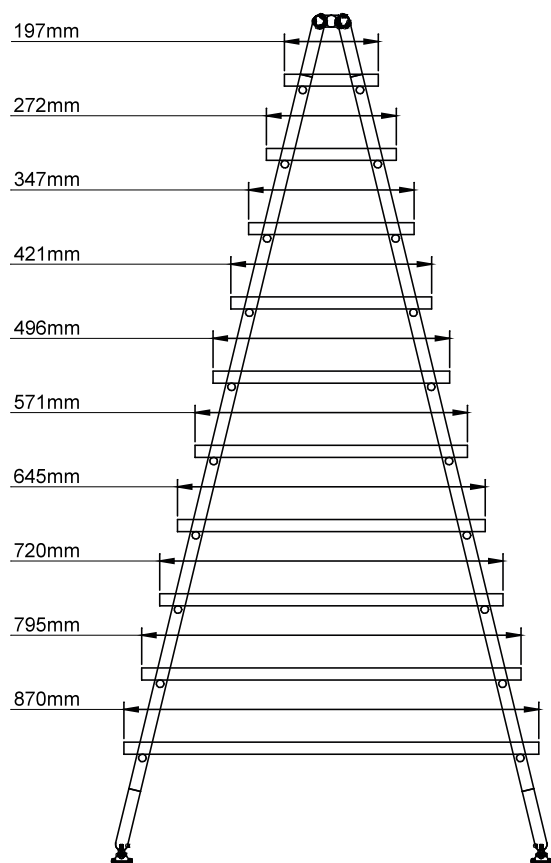

# 9 SPE1945 - DIVISÓRIA MODELO A FRAME PARA PRATELEIRAS

LARGURA DAS PRATELEIRAS

SPE1945 + SPE2525  
DOIS MÓDULOS + VÃO  
SPE2530  
SPE2540

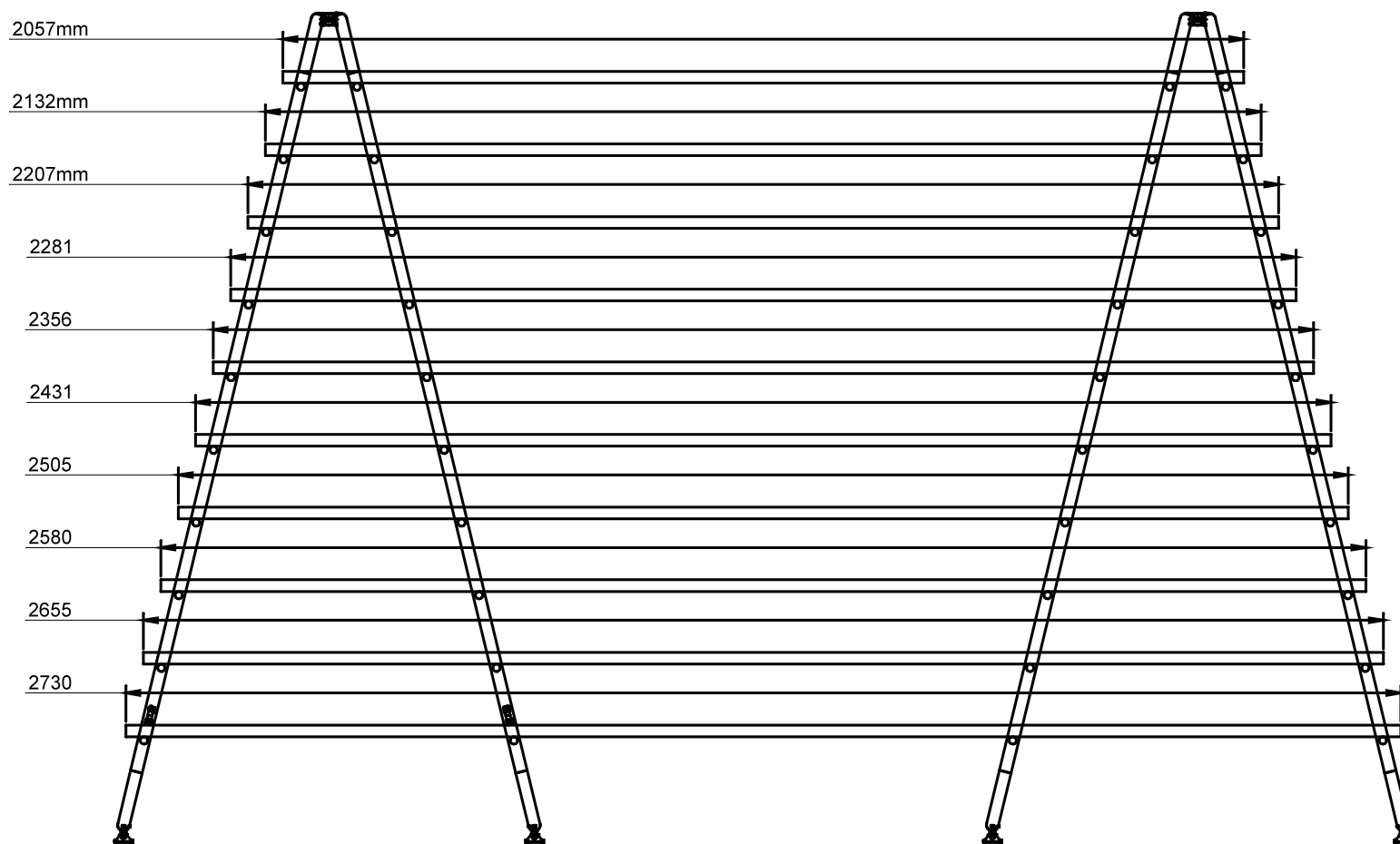

# 10 SPE1945 - DIVISÓRIA MODELO A FRAME PARA PRATELEIRAS

LARGURA DAS PRATELEIRAS

SPE1945 + SPE2525  
TRÊS MÓDULOS SPE2530  
SPE2540

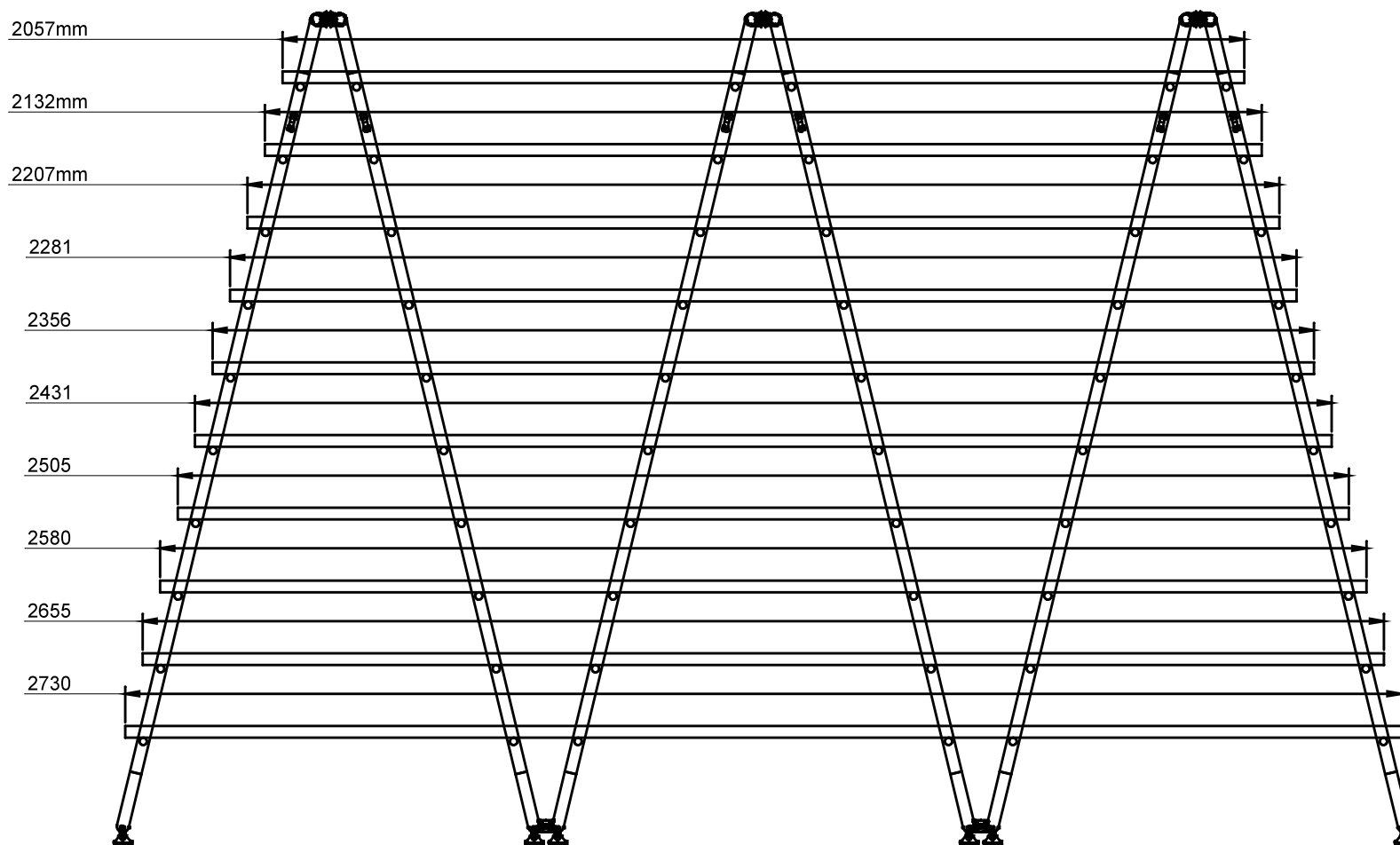

# 11 SPE1945 - DIVISÓRIA MODELO A FRAME PARA PRATELEIRAS

## LARGURA DAS PRATELEIRAS CENTRAIS

SPE1945 + SPE2525 + SPE2526 + SPE2525  
DOIS MÓDULOS + SPE2530 + SPE2531 + SPE2530  
+ VÃO SPE2540 SPE2541 SPE2540

