

Capacidade de Carga - Load Capacity - Capacidad de carga

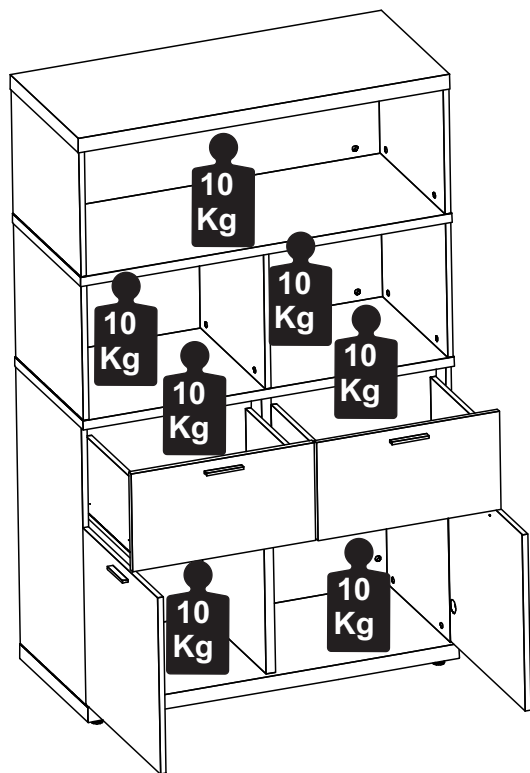

Manutenção e Limpeza

Vidros: pano levemente umedecido com álcool, seguido de pano seco.
Madeiras: pano levemente umedecido com água, seguido de pano seco.
*Nunca utilizar produtos químicos ou abrasivos.

Maintenance and Cleaning

Glasses: cloth lightly moistened with alcohol, followed by dry cloth.
Woods: cloth slightly moistened with water, followed by cloth seco.
*Never use chemicals or abrasives.

Mantenimiento y Limpieza

Vidrios: legeramente humedecido con alcohol, seguido de un paño seco.
Madera: ligeramente humedecido con agua, seguido de un paño seco.
*No utilice nunca productos quimicos o abrasivos.

INSTRUÇÕES DE MONTAGEM ASSEMBLY INSTRUCTIONS INSTRUCCIONES DE MONTAJE

ARMÁRIO ALTO COM NICHO HIGH CUPBOARD WITH NICHE ARMARIO ALTO CON NICHO

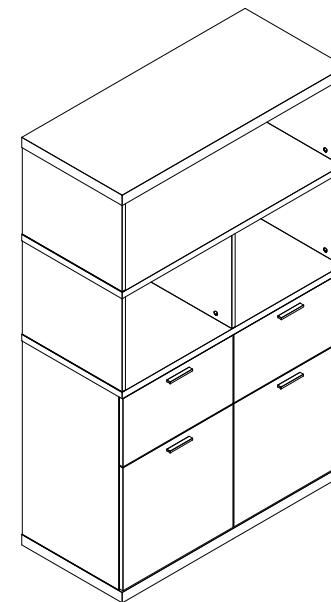

REF. #DOM1116



MOBILIÁRIO
PARA ESCRITÓRIO

GEBB Work Ind. de Móveis Ltda.
Rua Felix Roman, 190
São Valentin

95709-170 - Bento Gonçalves - RS - Brasil
Fone: (0XX54) 3454-1105 - (0XX54) 3453-1407
Phone: (0XX54) 3454-1105 - (0XX54) 3453-1407
E-mail: pedidos@gebbwork.com.br
www.gebbwork.com.br
WhatsApp: +55 54 99177-8324



2 P.



8mm



30mim

LISTA DE PEÇAS

LISTA DE PEÇAS

- 01 - Lateral Dir/Esq Inferior
- 02 - Tampo
- 03 - Base
- 04 - Lateral Dir/Esq Superior
- 05 - Divisória Inferior
- 06 - Lateral Dir/Esq Central
- 07 - Costa Inferior
- 08 - Costa Superior
- 10 - Divisória Superior
- 11 - Costa Central
- 12 - Prateleira Central Inferior
- 13 - Prateleira Central Superior
- 14 - Portas
- 15 - Lateral Esq Gaveteiro
- 16 - Lateral Dir Gaveteiro
- 17 - Costa Gaveteiro
- 18 - Frente Gaveteiro
- 19 - Fundo Gaveteiro

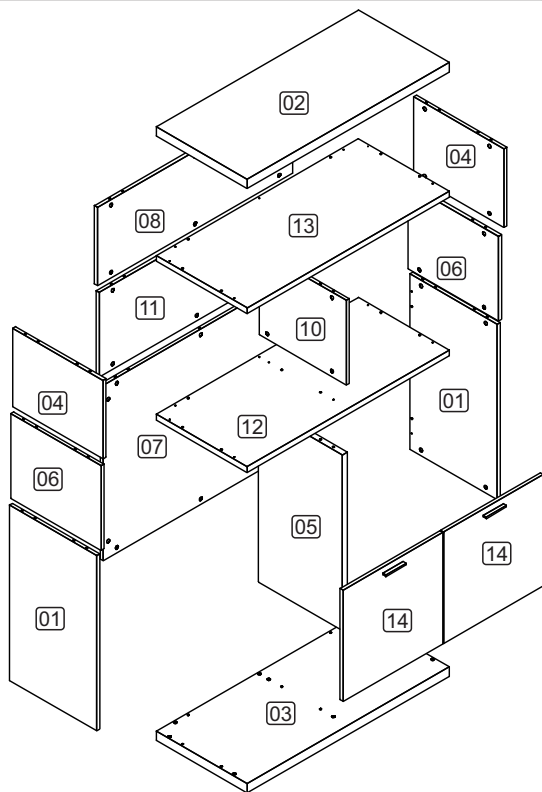
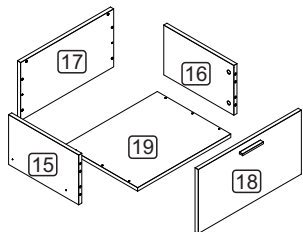

LISTA DE PIEZAS

- 01 - Lado inferior derecho/izquierdo
- 02 - Arriba
- 03 - Base
- 04 - Lado superior derecho/izquierdo
- 05 - Partición Inferior
- 06 - Central Derecha/Lado Izquierdo
- 07 - Costa Baja
- 08 - Costa Alta
- 10 - Partición superior
- 11 - Costa Central
- 12 - Estante central inferior
- 13 - Estante central superior
- 14 - Puertas
- 15 - Cajón lateral izquierdo
- 16 - Cajón lateral derecho
- 17 - Costa del cajón
- 18 - Cajón frontal
- 19 - Fondo del cajón

PARTS IDENTIFICATION

- 01 - Lower Right/Left Side
- 02 - Top
- 03 - Basis
- 04 - Upper Right/Left Side
- 05 - Lower Partition
- 06 - Central Right/Left Side
- 07 - Lower Coast
- 08 - Upper Coast
- 10 - Upper Partition
- 11 - Central Coast
- 12 - Lower Central Shelf
- 13 - Upper Central Shelf
- 14 - Doors
- 15 - Left Side Drawer
- 16 - Side Right Drawer
- 17 - Drawer Coast
- 18 - Front Drawer
- 19 - Drawer Bottom

Encaixe as gavetas no armário

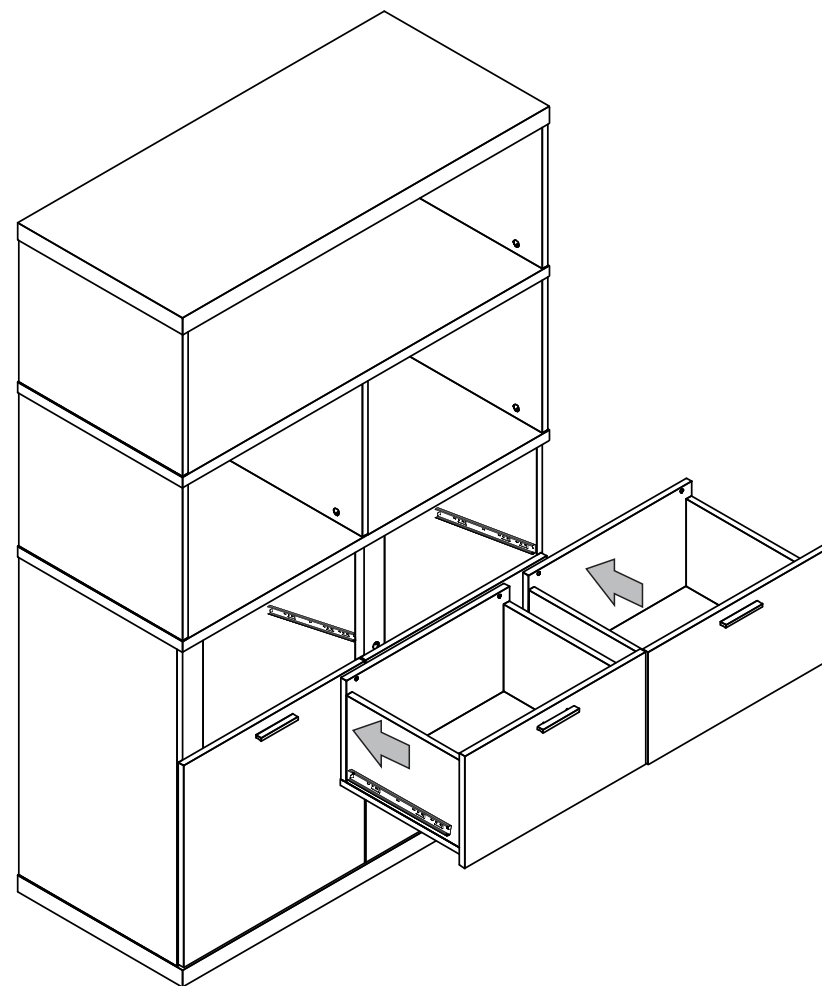

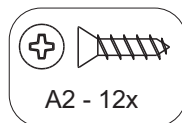
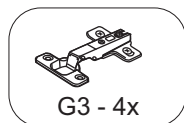
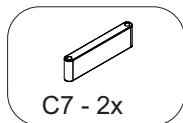
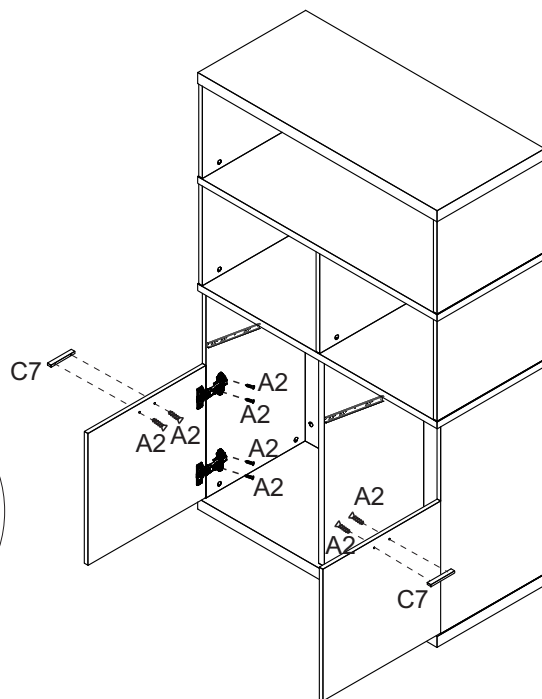
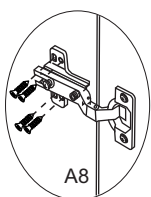
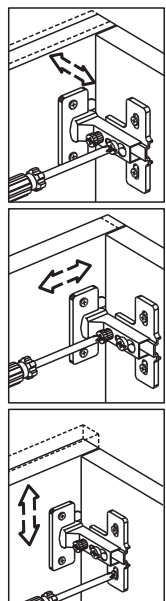
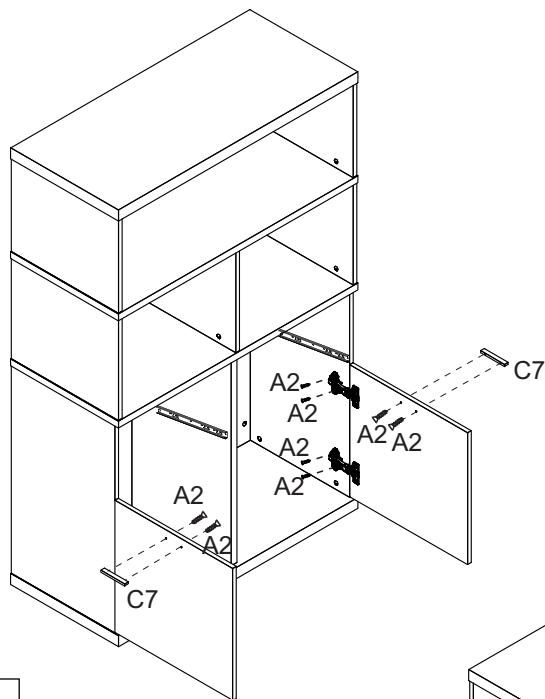

ACESSÓRIOS ACCESSORIES ACCESORIOS

A6 - PARAF. 3,5x40 CC
16x



A2 - PARAF. 3,5x14 CC
24x



A8 - PARAF. 4,0x14 CP
24x



A32 - PARAF. MINIFIX
46x

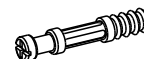

A29 - PARAF. MINIFIX
M6x33mm **16x**

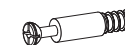

A35 - TAMBOR MINIFIX
62x



B16 HASTEMET.
353mm **4x**



A36 - BUCHA M6x13
16x



D1 - CAVILHA 8x30
65x

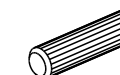

G3 - DOBRADIÇA 35 C/PISTÃO BAIXA + CALÇO **4x**

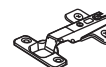

F1 - TAPA FURO Ø18
62x



J3 - TRILHO TELESC. 350mm **2x**



L15 - CONJ. DESLIZADOR P/ARMÁRIO MACHO/FEMEA **4x**



C7 - PUXADOR
4x



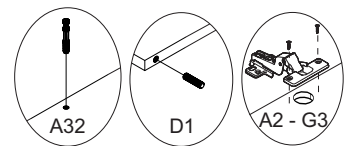
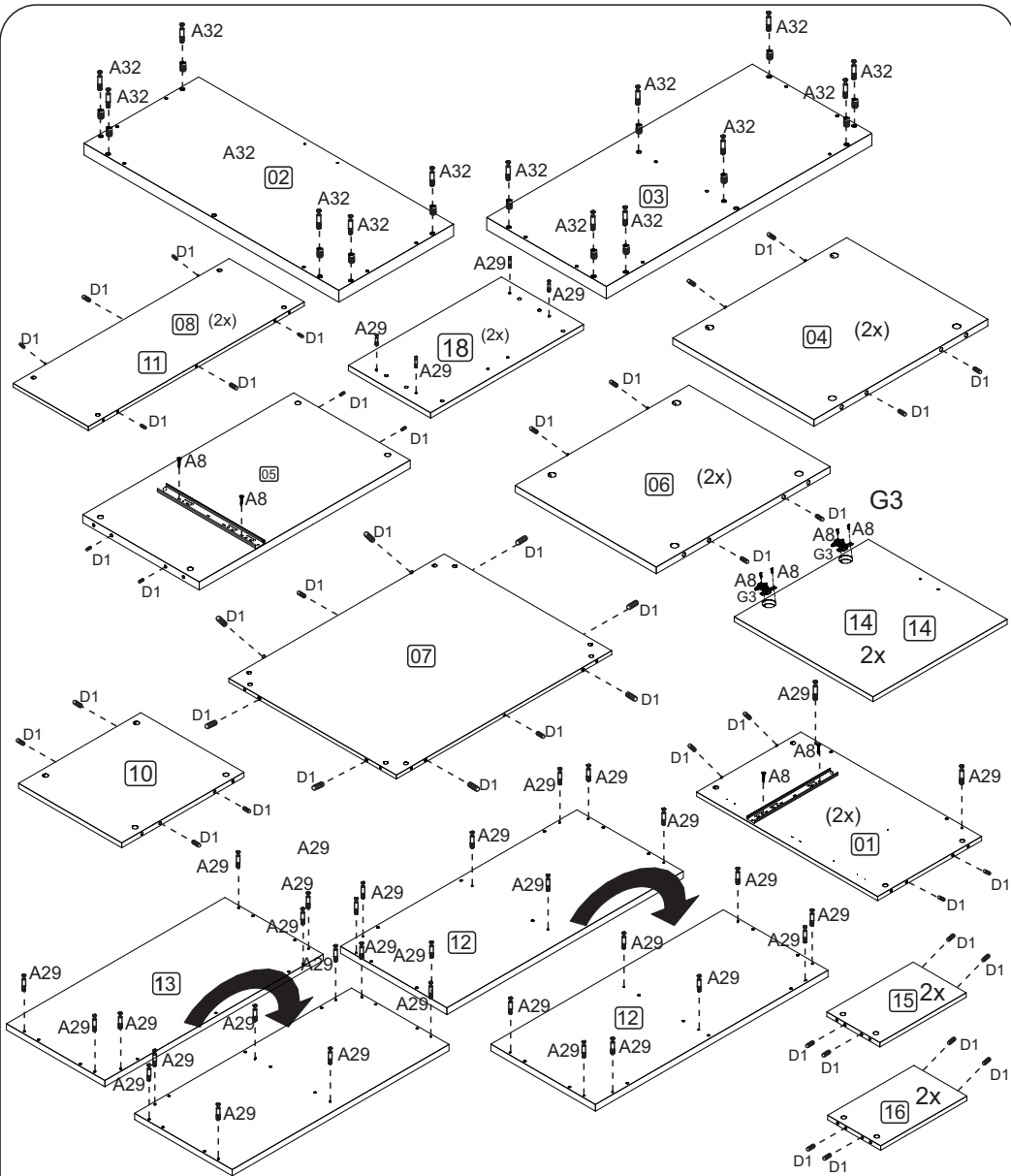

- A36 - 14x
- A29 - 14x
- A8 - 16x
- A32 - 42x
- D1 - 70x
- G3 - 4x
- J3 - 2x

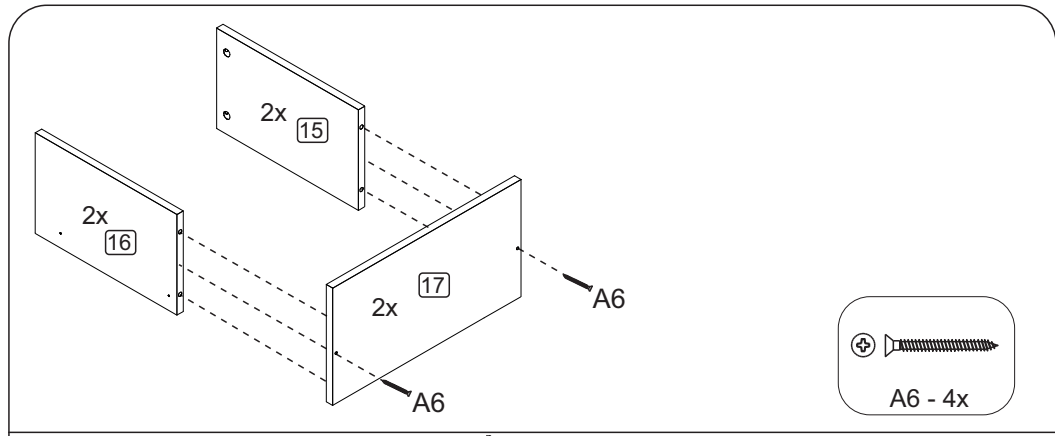

- A6 - 4x

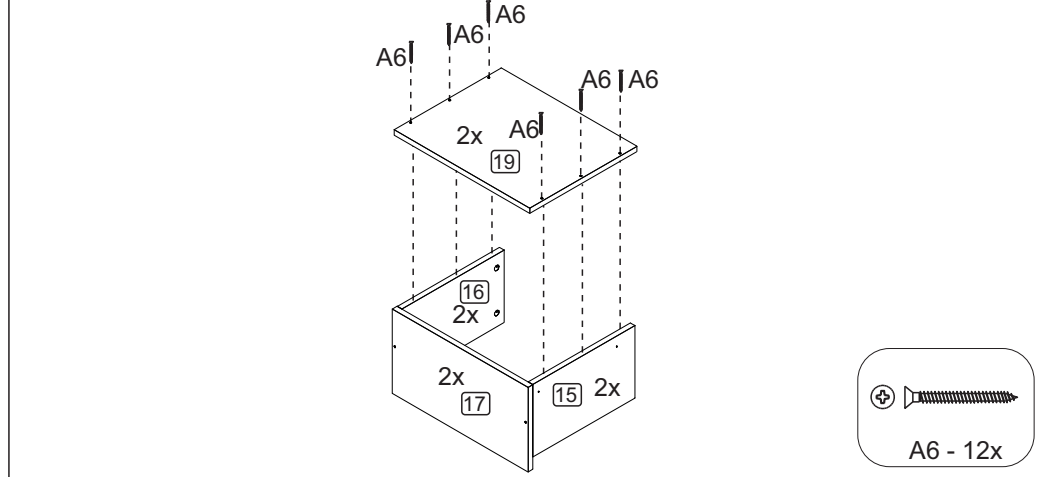

- A6 - 12x

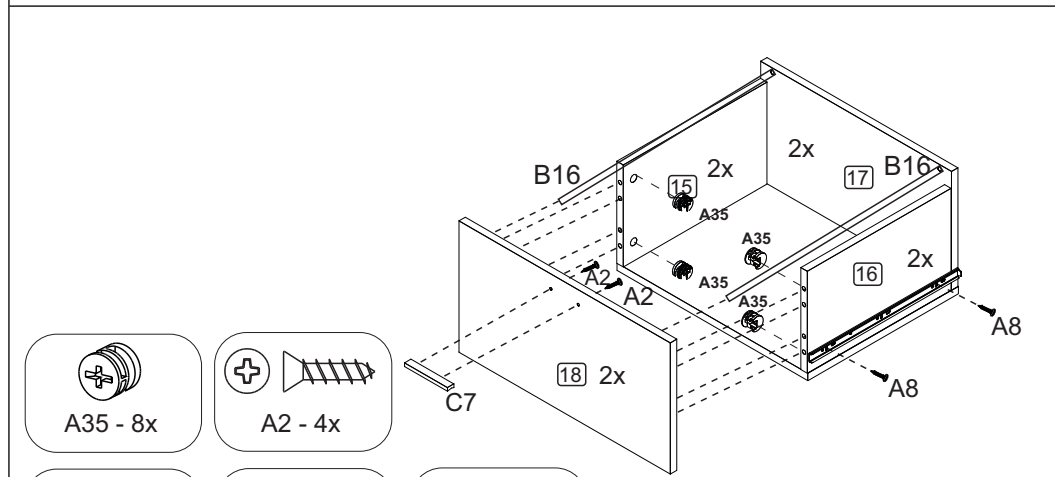

- A35 - 8x
- A2 - 4x
- A8 - 8x
- C7 - 2x
- B16 - 4x

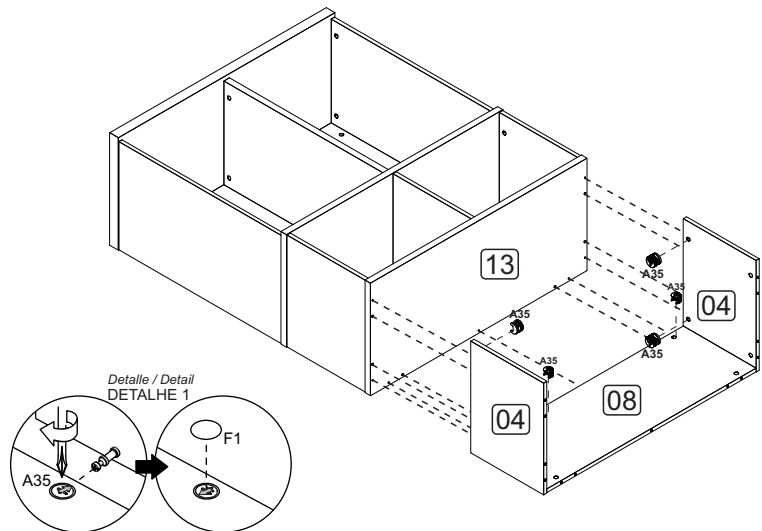

Depois de encaixar as peças coloque o tambor com a sua seta voltada para o parafuso. Para apertar Gire no sentido horário.
 Después de colocar las piezas, coloque el tambor con su flecha hacia el tornillo. Para apretar, gire en sentido horario.
 After fitting the parts, place the drum with its arrow facing the screw. To tighten, turn clockwise.

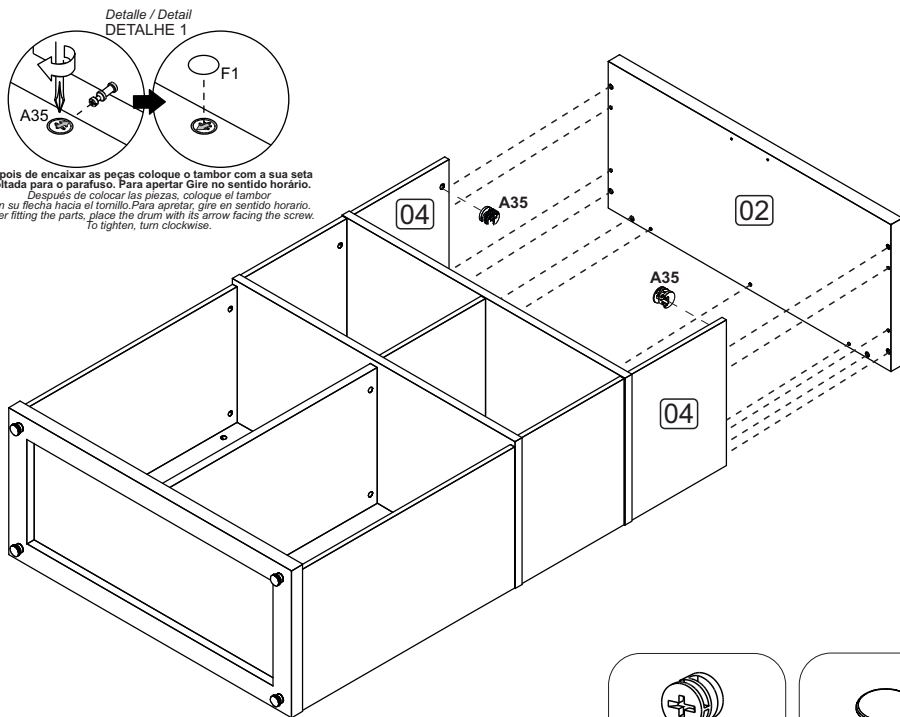
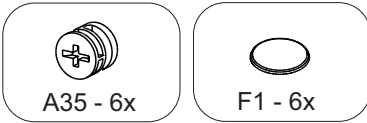

Depois de encaixar as peças coloque o tambor com a sua seta voltada para o parafuso. Para apertar Gire no sentido horário.
 Después de colocar las piezas, coloque el tambor con su flecha hacia el tornillo. Para apretar, gire en sentido horario.
 After fitting the parts, place the drum with its arrow facing the screw. To tighten, turn clockwise.

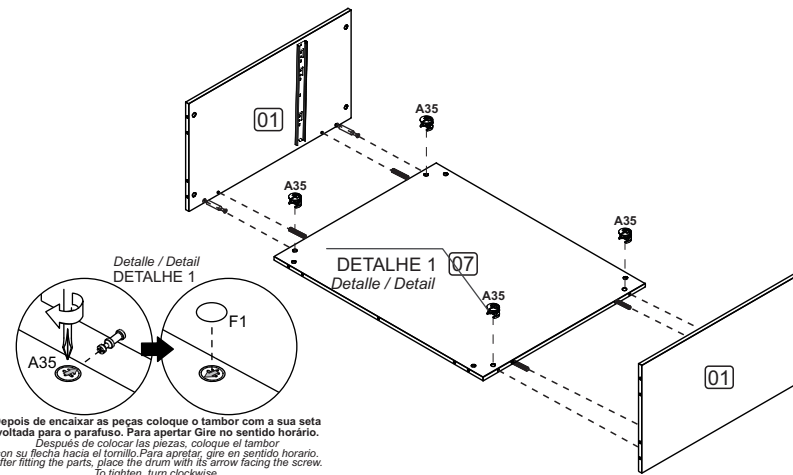

Depois de encaixar as peças coloque o tambor com a sua seta voltada para o parafuso. Para apertar Gire no sentido horário.
 Después de colocar las piezas, coloque el tambor con su flecha hacia el tornillo. Para apretar, gire en sentido horario.
 After fitting the parts, place the drum with its arrow facing the screw. To tighten, turn clockwise.

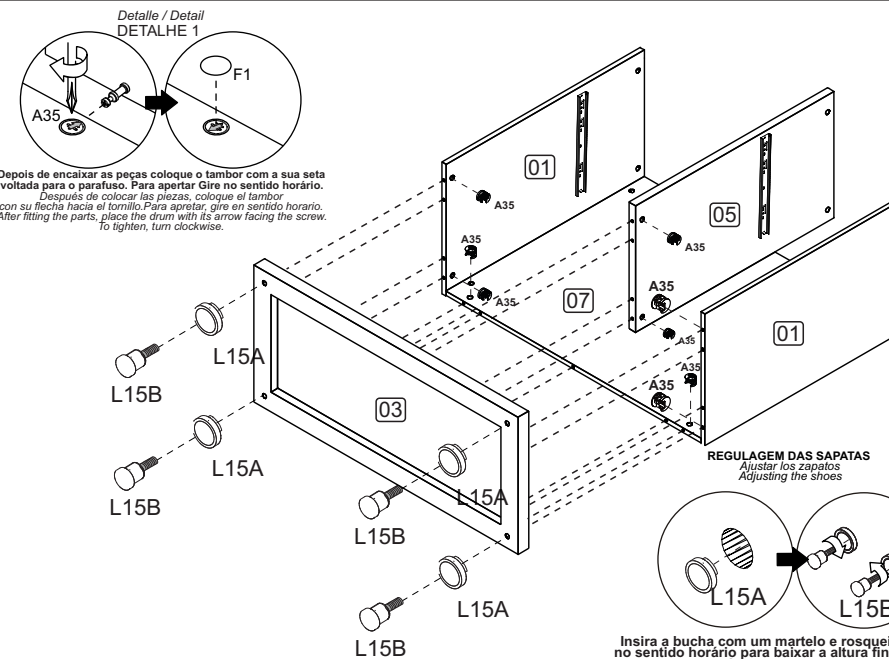
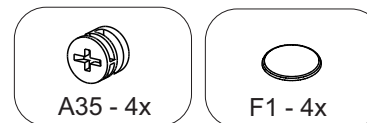

Depois de encaixar as peças coloque o tambor com a sua seta voltada para o parafuso. Para apertar Gire no sentido horário.
 Después de colocar las piezas, coloque el tambor con su flecha hacia el tornillo. Para apretar, gire en sentido horario.
 After fitting the parts, place the drum with its arrow facing the screw. To tighten, turn clockwise.

REGULAGEM DAS SAPATAS
 Ajustar los zapatos
 Adjusting the shoes

Insira a bucha com um martelo e rosqueie a sapata no sentido horário para baixar a altura final do móvel e, sentido anti-horário para aumentar a altura do móvel. Inserte el portabrocas con un martillo y gírrale la zapata en el sentido de las agujas del reloj para bajar la altura final del mueble y en el sentido contrario a las agujas del reloj para aumentar la altura del mueble. Insert the chuck with a hammer and screw the shoe clockwise to lower the final height of the furniture and counterclockwise to increase the height of the furniture.

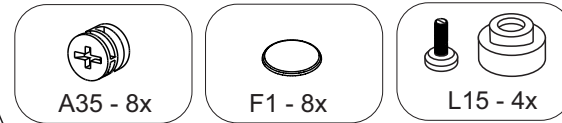

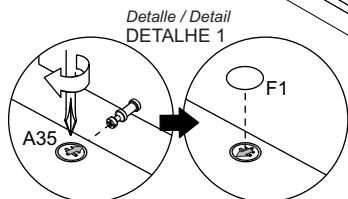
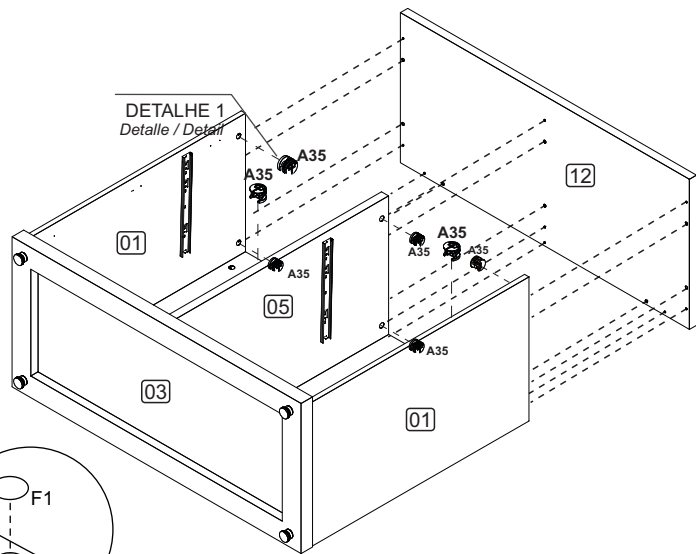

Depois de encaixar as peças coloque o tambor com a sua seta voltada para o parafuso. Para apertar Gire no sentido horário.
 Después de colocar las piezas, coloque el tambor con su flecha hacia el tornillo. Para apretar, gire en sentido horario.
 After fitting the parts, place the drum with its arrow facing the screw. To tighten, turn clockwise.

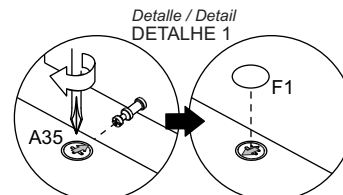
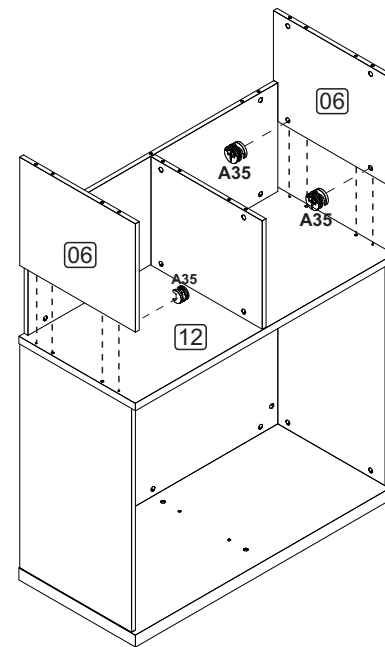

Depois de encaixar as peças coloque o tambor com a sua seta voltada para o parafuso. Para apertar Gire no sentido horário.
 Después de colocar las piezas, coloque el tambor con su flecha hacia el tornillo. Para apretar, gire en sentido horario.
 After fitting the parts, place the drum with its arrow facing the screw. To tighten, turn clockwise.

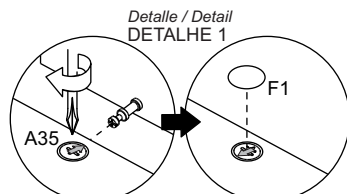
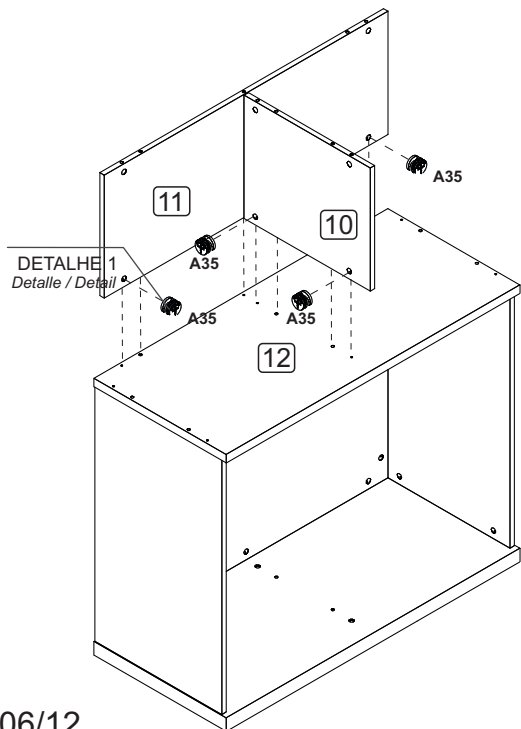

Depois de encaixar as peças coloque o tambor com a sua seta voltada para o parafuso. Para apertar Gire no sentido horário.
 Después de colocar las piezas, coloque el tambor con su flecha hacia el tornillo. Para apretar, gire en sentido horario.
 After fitting the parts, place the drum with its arrow facing the screw. To tighten, turn clockwise.

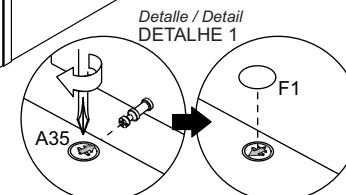
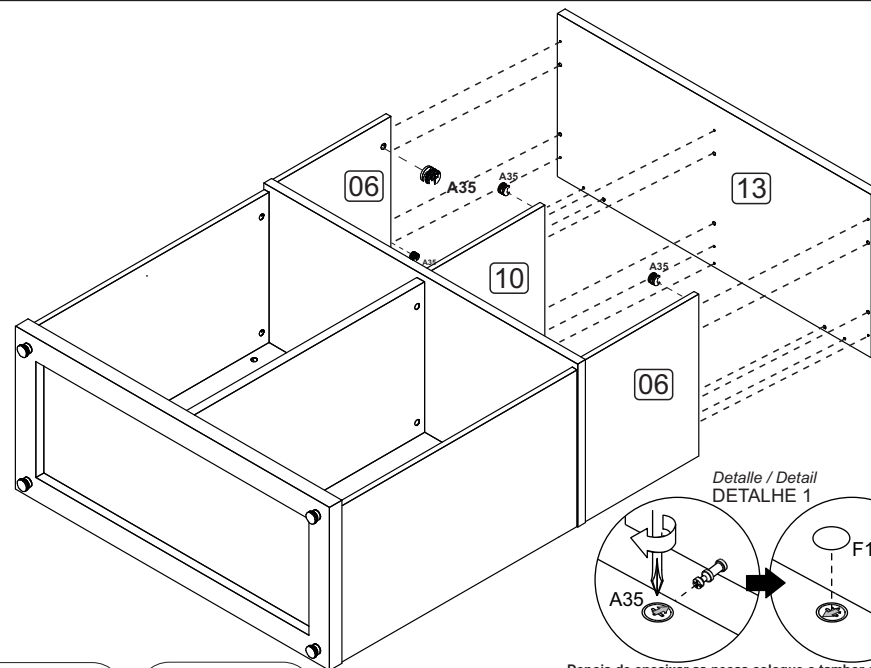
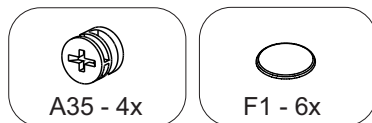

Depois de encaixar as peças coloque o tambor com a sua seta voltada para o parafuso. Para apertar Gire no sentido horário.
 Después de colocar las piezas, coloque el tambor con su flecha hacia el tornillo. Para apretar, gire en sentido horario.
 After fitting the parts, place the drum with its arrow facing the screw. To tighten, turn clockwise.

