

Capacidade de Carga - Load Capacity - Capacidad de carga

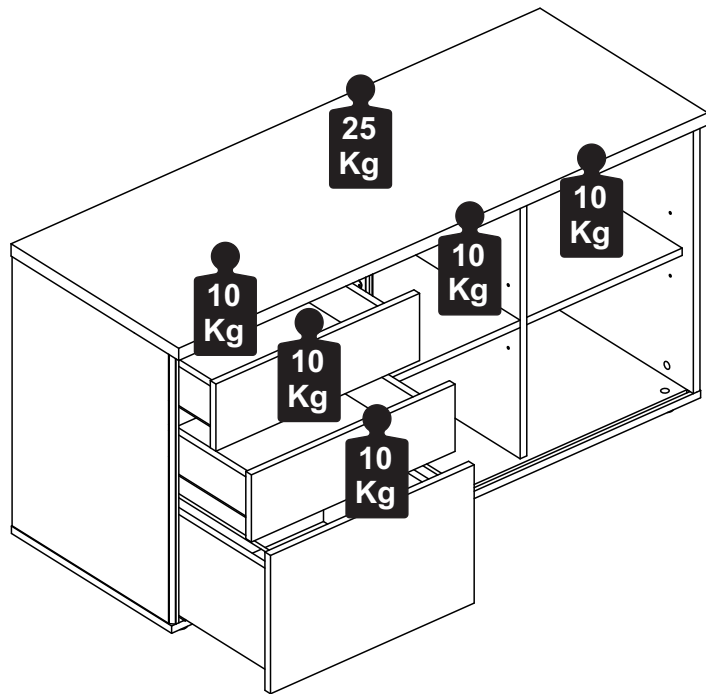

Manutenção e Limpeza

Vidros: pano levemente umedecido com álcool, seguido de pano seco.
Madeiras: pano levemente umedecido com água, seguido de pano seco.
*Nunca utilizar produtos químicos ou abrasivos.

Maintenance and Cleaning

Glasses: cloth lightly moistened with alcohol, followed by dry cloth.
Woods: cloth slightly moistened with water, followed by cloth seo.
*Never use chemicals or abrasives.

Mantenimiento y Limpieza

Vidrios: legeramente humedecido con alcohol, seguido de un paño seco.
Madera: ligeramente humedecido con agua, seguido de un paño seco.
*No utilice nunca productos quimicos o abrasivos.

INSTRUÇÕES DE MONTAGEM ASSEMBLY INSTRUCTIONS INSTRUCCIONES DE MONTAJE

ARMÁRIO BAIXO 2 GAV/1PASTA/PORTA CORRER ARMÁRIO BAJO 3 CAJONES Y PUERTA MÓVIL LOW CABINET 3 DRAWERS AND SLIDING DOOR

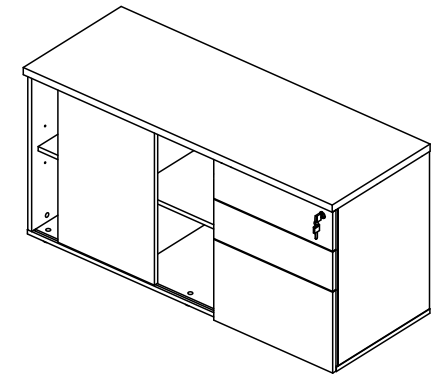
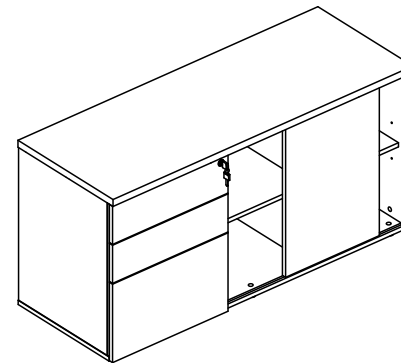

1 P.



35mim

REF. #LEX1263

 **Gebbwork**

MOBILIÁRIO
PARA ESCRITÓRIO

GEBB Work Ind. de Móveis Ltda.
Rua Felix Roman, 190
São Valentin

95709-170 - Bento Gonçalves - RS - Brasil
Fone: (0XX54) 3454-1105 - (0XX54) 3453-1407
Phone: (0XX54) 3454-1105 - (0XX54) 3453-1407
E-mail: pedidos@gebbwork.com.br

www.gebbwork.com.br

WhatsApp: +55 54 99177-8324

LISTA DE PEÇAS

LISTA DE PEÇAS

- 01 - Lateral Esquerda
- 02 - Lateral Direita
- 03 - Tampo
- 04 - Base
- 05 - Divisória Porta
- 06 - Frente de Gaveta
- 07 - Divisória Gaveta
- 08 - Prateleira
- 09 - Porta
- 10 - Costa Maior
- 11 - Costa Menor
- 12 - Frente Gaveta com Chave
- 13 - Lateral Gaveta Direita
- 14 - Lateral Gaveta Esquerda
- 15 - Costa Gaveta
- 16 - Fundo Gaveta
- 17 - Costa Gaveta Maior
- 18 - Lateral Gaveta Direita Maior
- 19 - Lateral Gaveta Esquerda Maior
- 20 - Frente Gaveta Maior

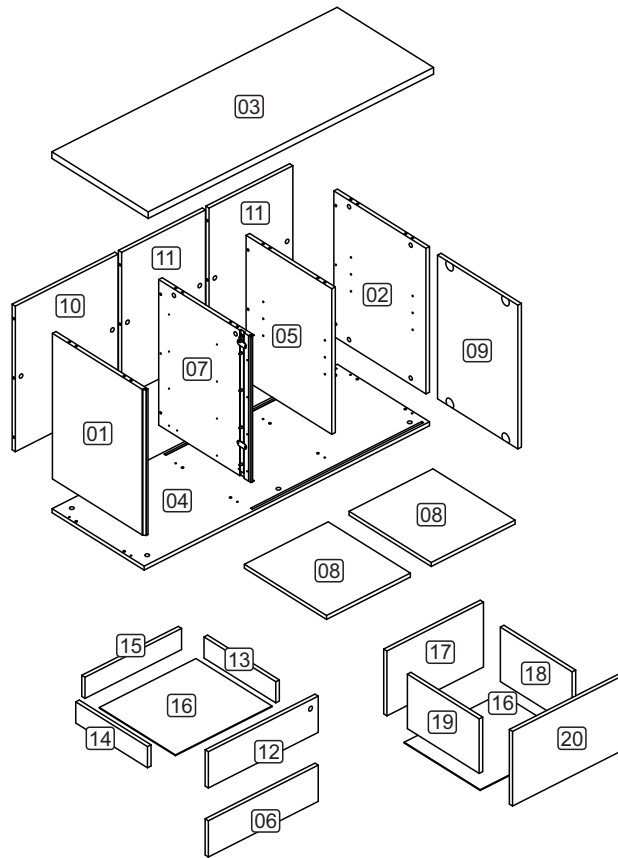





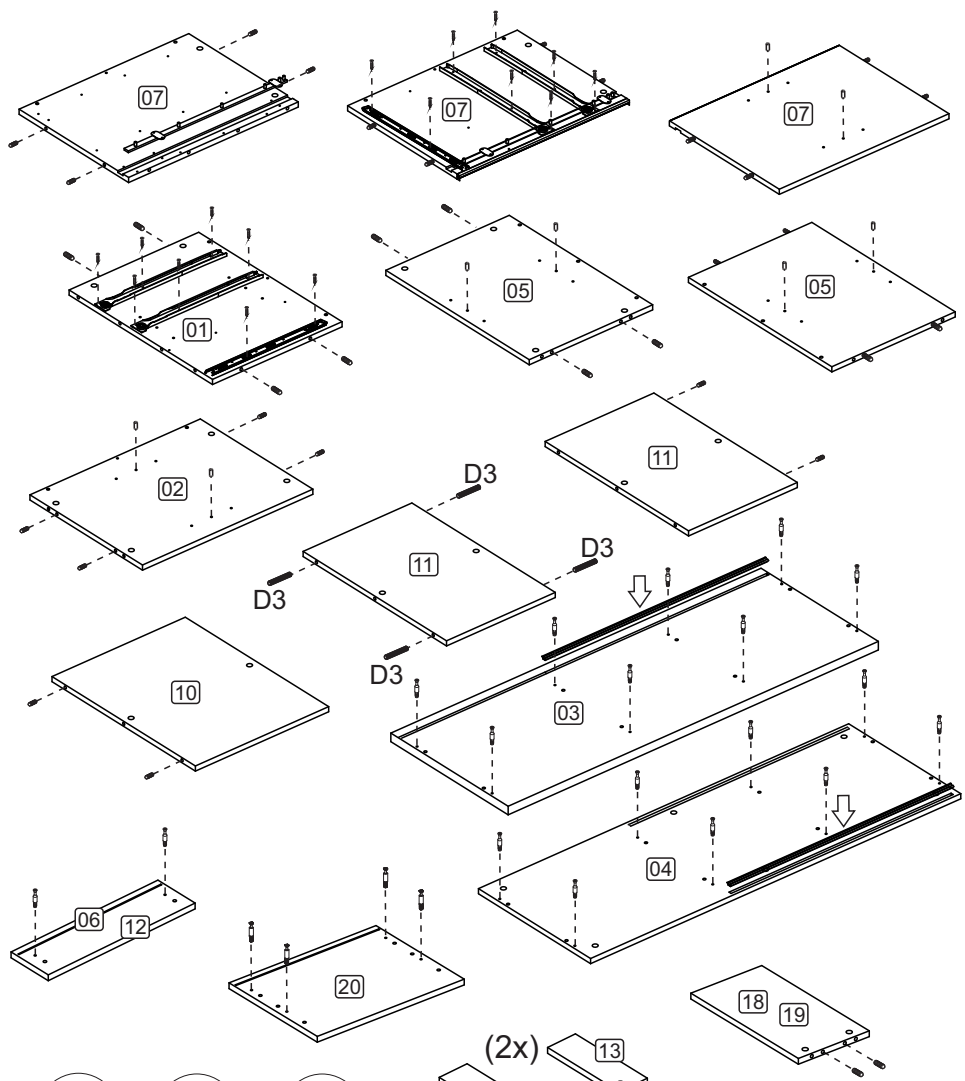

LISTA DE PIEZAS

- 01 - Lateral Izquierda
- 02 - Lateral Derecha
- 03 - Tapa
- 04 - Base
- 05 - Divisória Puerta
- 06 - Frente Cajón
- 07 - Panel Lateral
- 08 - Repisa
- 09 - Puerta
- 10 - Panel Delantero
- 11 - Revés Armário
- 12 - Frente Cajón con LLave
- 13 - Lateral Cajón Derecha
- 14 - Lateral Cajón Izquierda
- 15 - Revés Cajón
- 16 - Fondo Cajón
- 17 - Revés Cajón
- 18 - Lateral Cajón Derecha
- 19 - Lateral Cajón Izquierda
- 20 - Frente Cajón

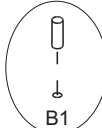

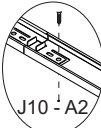
PARTS IDENTIFICATION

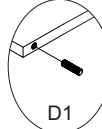
- 01 - Left Side
- 02 - Right Side
- 03 - Top
- 04 - Base
- 05 - Divider
- 06 - Drawer Front
- 07 - Panel Side
- 08 - Shelf
- 09 - Door
- 10 - Panel Front
- 11 - Revés
- 12 - Drawer Front
- 13 - Drawer Right Side
- 14 - Drawer Left Side
- 15 - Drawer Back
- 16 - Drawer Bottom
- 17 - Large Drawer Back
- 18 - Large Drawer Right Side
- 19 - Large Drawer Left Side
- 20 - Large Drawer Front

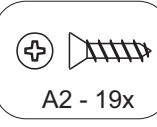
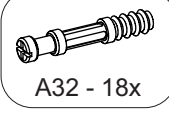
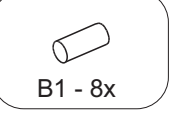
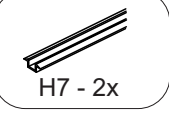
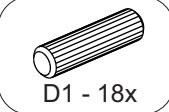
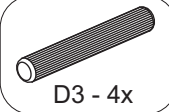
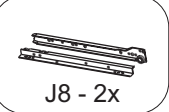
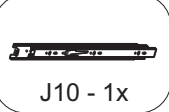

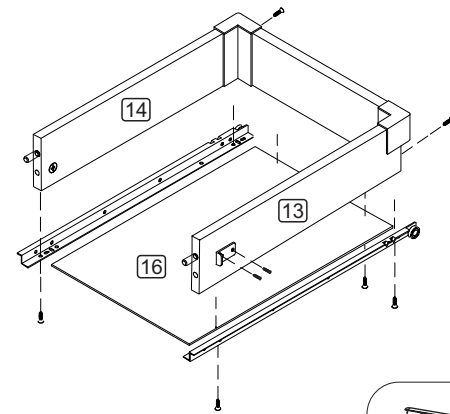
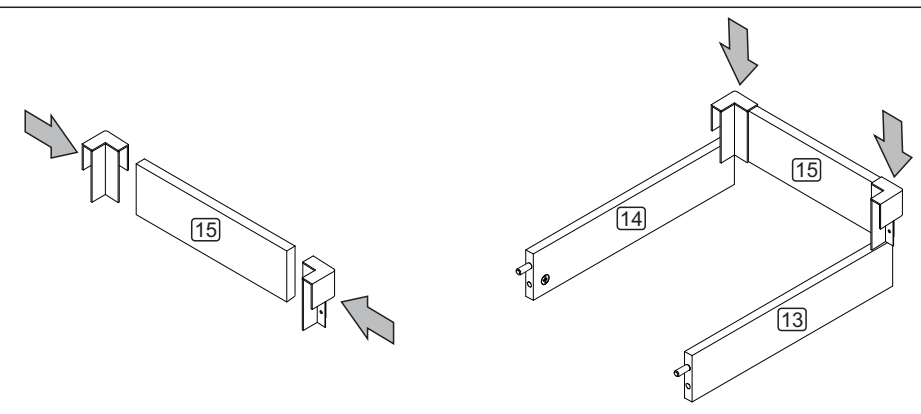
-  B1
-  H7
-  J10 - A2
-  A32
-  D1
-  J8 - A2
-  A2 - 19x
-  A32 - 18x
-  B1 - 8x
-  H7 - 2x
-  D1 - 18x
-  D3 - 4x
-  J8 - 2x
-  J10 - 1x

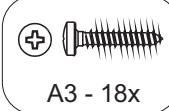
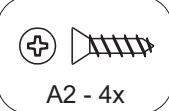
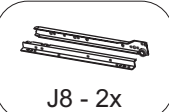

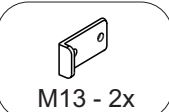
-  A3 - 18x
-  A2 - 4x
-  J8 - 2x
-  H6 - 4x
-  M13 - 2x

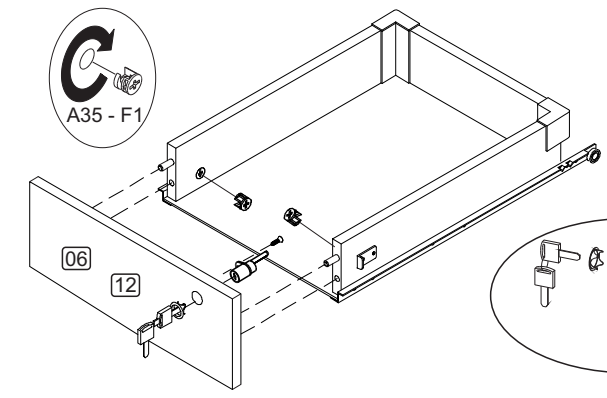

-  A2 - 1x
-  A35 - 4x
-  F1 - 4x
-  I2 - 1x

(1x)

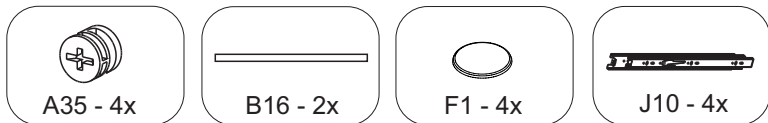
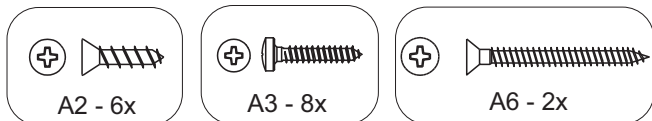
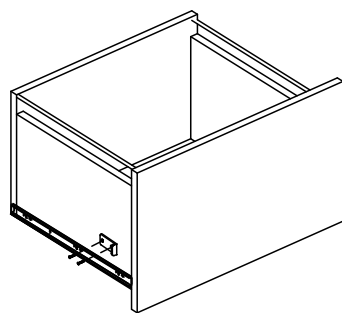
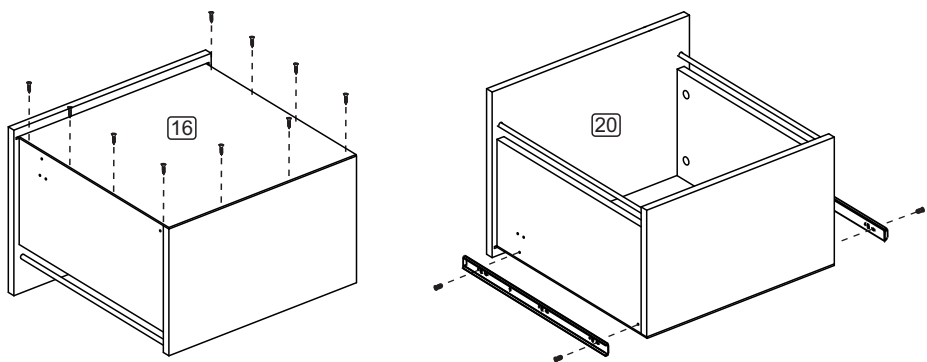
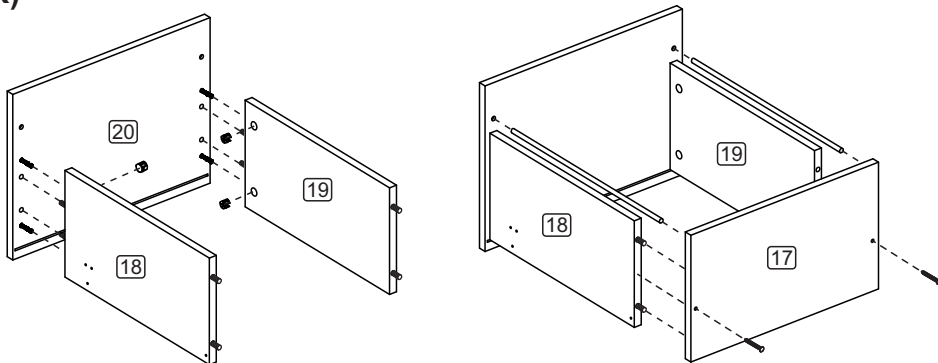

ACESSÓRIOS ACCESSORIES ACCESORIOS

A2 - PARAF. 3,5x14 CC
27x



A3 - PARAF. 3,5x20 CP
25x



A6 - PARAF. 3,5x40 CC
06x



A32 - PARAF. MINIFIX
22x

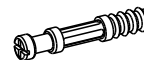

A35 - TAMBOR MINIFIX
26x



A33 - PARAF. MINIFIX DP
2x

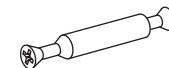

B1 - SUPORTE PRAT.
METÁLICO 8x



B15 - HASTE MET.
293mm 2x



D1 - CAVILHA 8x30
34x

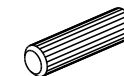

D3 - CAVILHA 8x50
4x

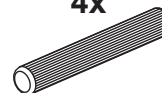

D6 - CAVILHA PLÁSTICA
ESCALONADA 8/6x30 8x



F1 - TAPA FURO Ø18
18x



H6 - CANTONEIRA P/GAV
QUICK INSTALL 4x



H10 - PERFIL PLÁSTICO
549MM 2x



H13 - PERFIL ALUMÍNIO
718mm 2x



I2 - FECHADURA FRONTAL
P/GAV. 1x



I4 - KIT PARA PORTA
DE CORRER 1x



I7 - BARRA TRAV. 515MM
P/4 GAV 1x



J8 - CORREDIÇA 400mm
1x



J10 - TRILHO TELESC. MINI
H35 LIGHT 450mm 1x



L4 - DESLIZADOR
P/ARMÁRIO 6x



M13 - TRAVA P/GAV.
37x14x10 ZB 3x



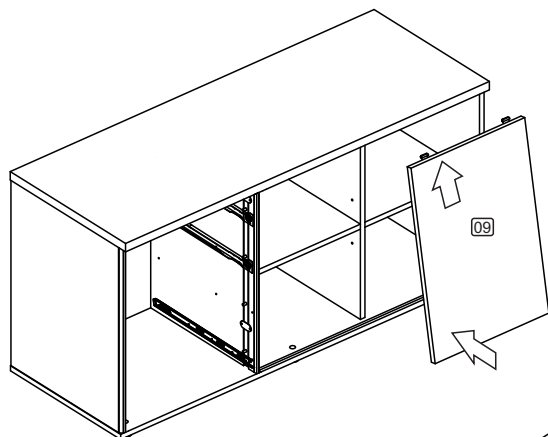
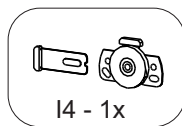
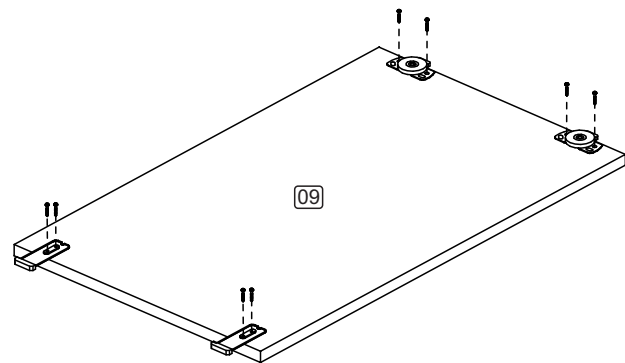

ESQUERDO

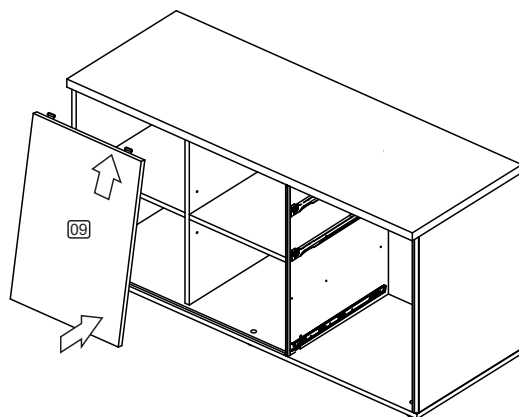

DIREITO

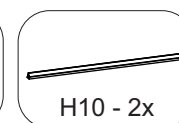
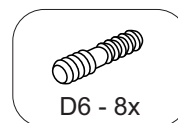
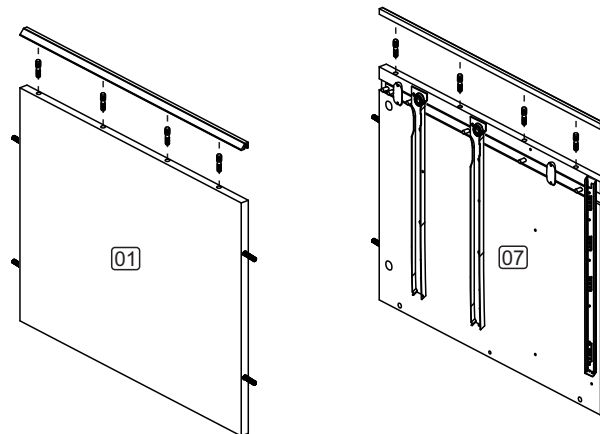

Se usar o modo esquerdo com o auxílio de uma parafusadeira, torne passante os furos da costa da divisória peça 07 com broca de $\varnothing 8$ passante

ESQUERDO

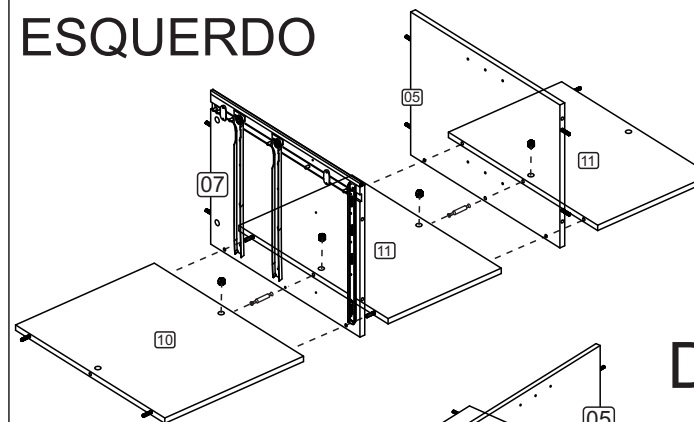

Se utilizar o modo direito, com o auxílio de uma parafusadeira, torne passante os furos de diâmetro $\varnothing 5$ para prateleira da lateral esquerda 01, e os furos da costa com diâmetro $\varnothing 8$ também na lateral esquerda 01, e utilize como divisória direita.

DIREITO

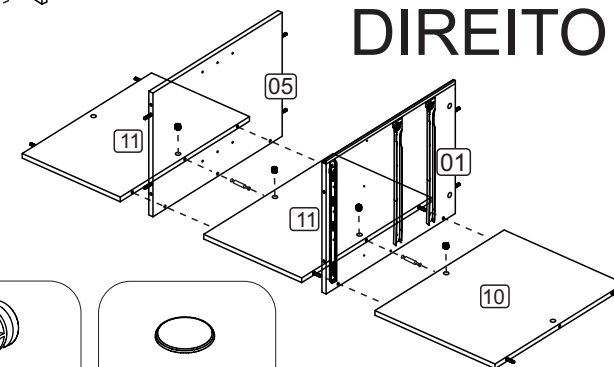
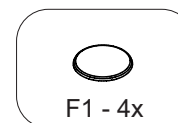
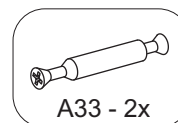

ESQUERDO

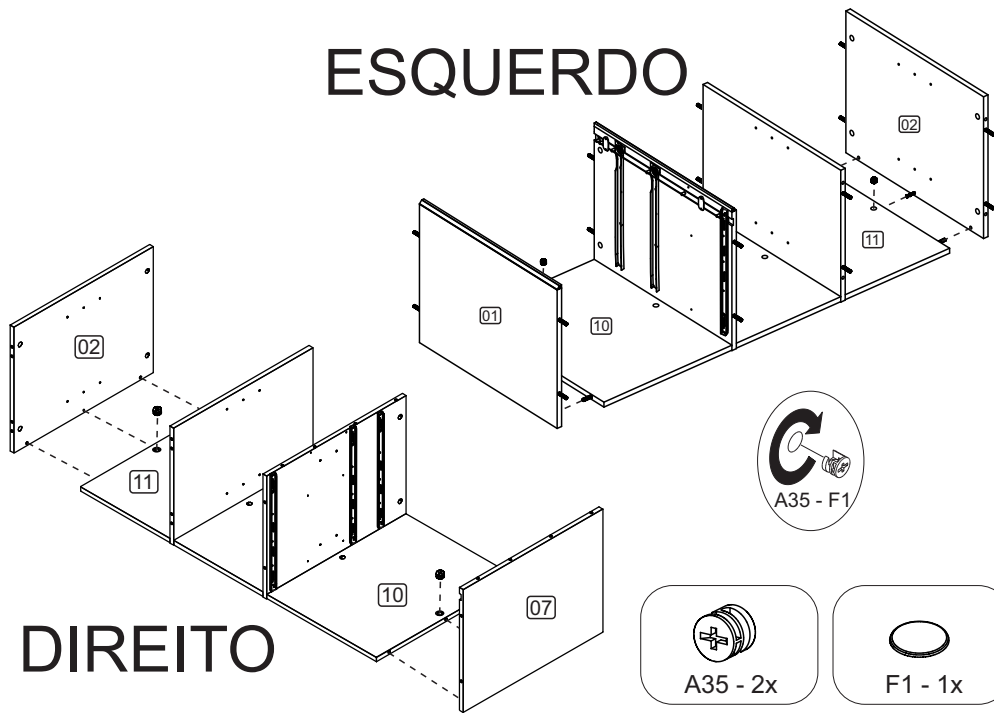

DIREITO

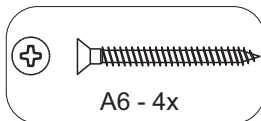
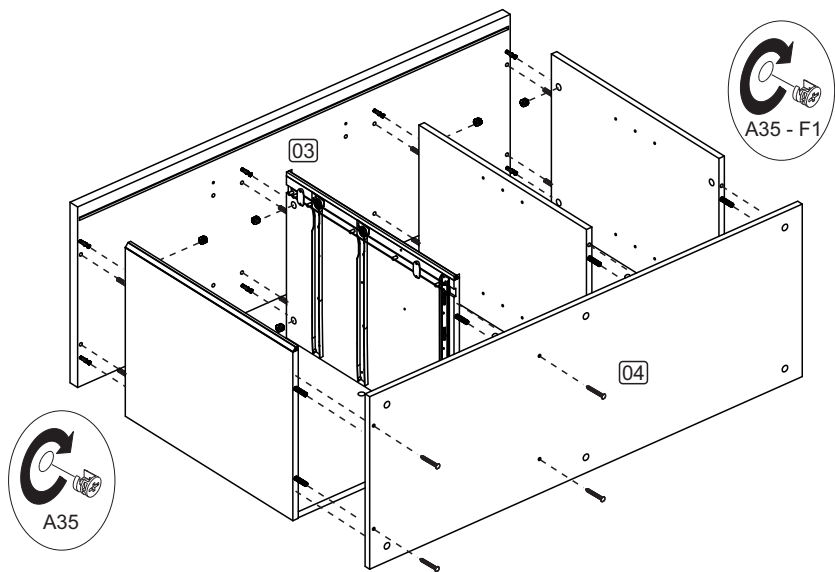
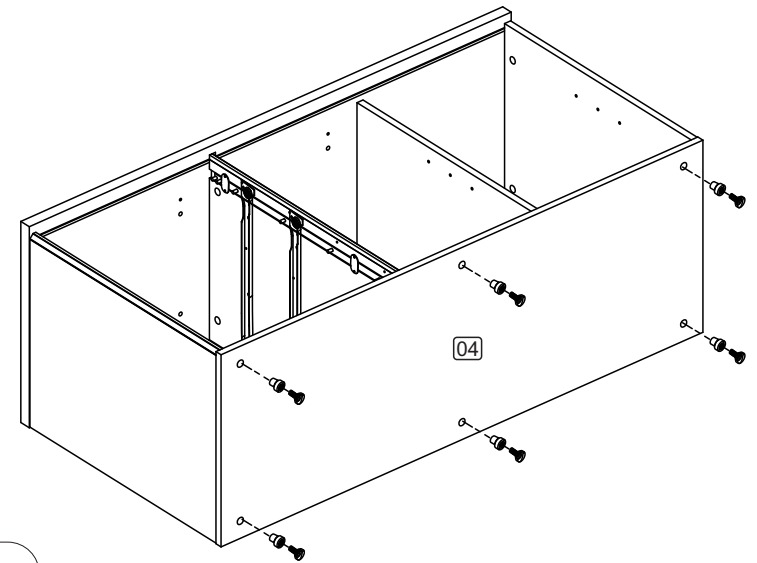

A6 - 4x

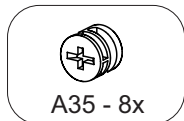

A35 - 8x

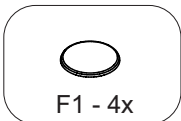

F1 - 4x

