

Capacidade de Carga - Load Capacity - Capacidad de carga

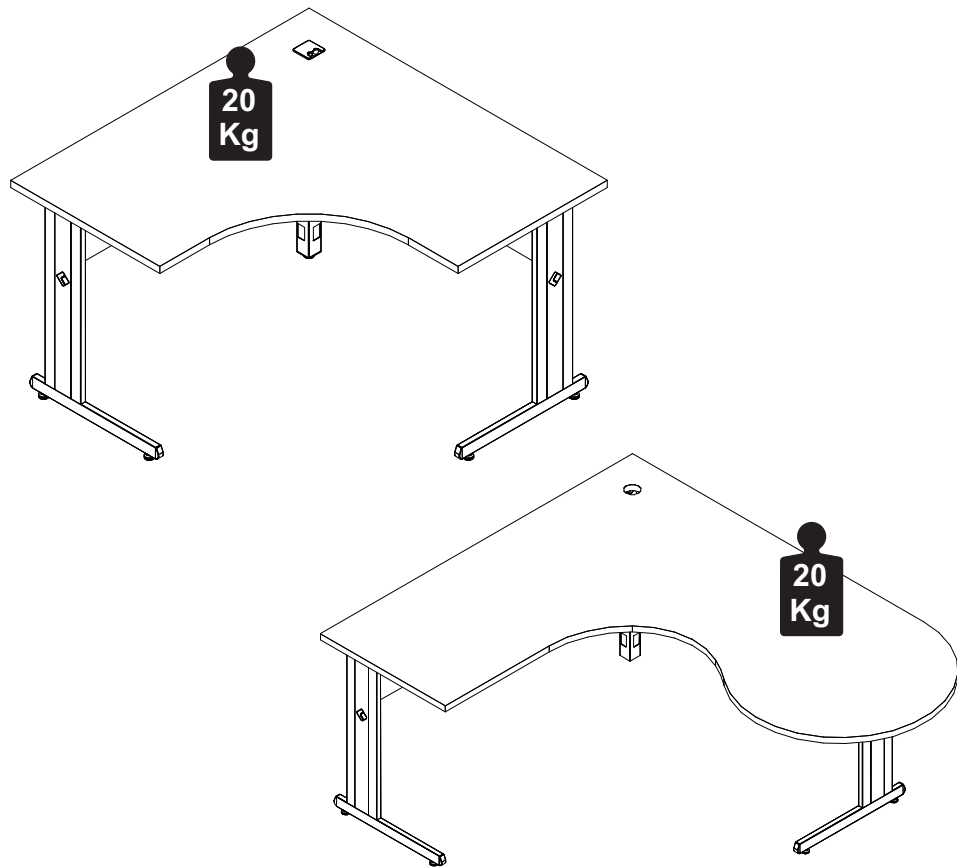

Manutenção e Limpeza

Vidros: pano levemente umedecido com álcool, seguido de pano seco.
Madeiras: pano levemente umedecido com água, seguido de pano seco.
*Nunca utilizar produtos químicos ou abrasivos.

Maintenance and Cleaning

Glasses: cloth lightly moistened with alcohol, followed by dry cloth.
Woods: cloth slightly moistened with water, followed by cloth seco.
*Never use chemicals or abrasives.

Mantenimiento y Limpieza

Vidrios: legeramente humedecido con alcohol, seguido de un paño seco.
Madera: ligeramente humedecido con agua, seguido de un paño seco.
*No utilice nunca productos quimicos o abrasivos.

INSTRUÇÕES DE MONTAGEM ASSEMBLY INSTRUCTIONS INSTRUCCIONES DE MONTAJE

MESA ANGULAR LIGHT ANGLE TABLE LIGHT LUZ DE MESA EN ÁNGULO

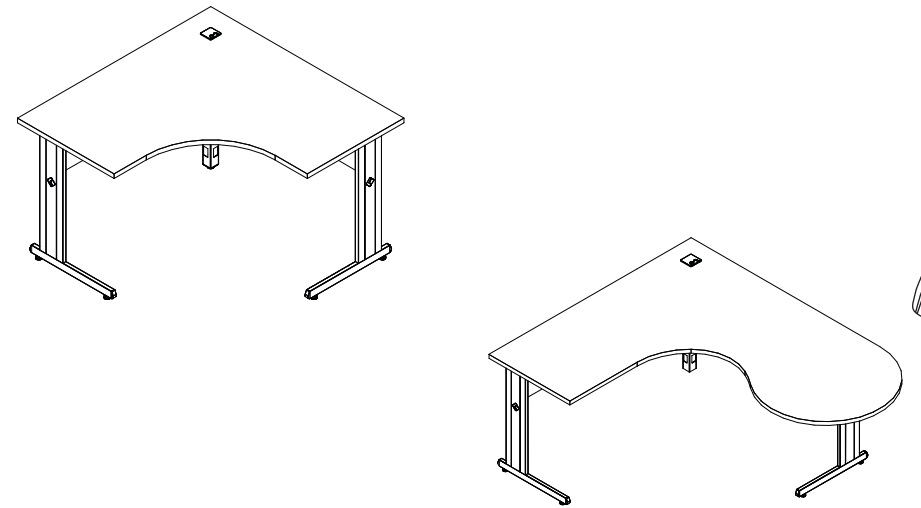

2 P.



20mim

REF. #LEX-EXP1227-1228-1229-1240-1241-1242-
1423-1424-1427-1428-1624-1627-1818-
1820-2018-2024-1224-1225-1226-1426



MOBILIÁRIO
PARA ESCRITÓRIO

GEBB Work Ind. de Móveis Ltda.
Rua Felix Roman, 190
São Valentin

95709-170 - Bento Gonçalves - RS - Brasil
Fone: (0XX54) 3454-1105 - (0XX54) 3453-1407
Phone: (0XX54) 3454-1105 - (0XX54) 3453-1407
E-mail: pedidos@gebbwork.com.br
www.gebbwork.com.br
WhatsApp: +55 54 99177-8324

LISTA DE PEÇAS

- 01 - Pé Metálico Esquerdo
- 02 - Pé Metálico Direito
- 03 - Tampo
- 04 - Painel Frontal
- 05 - Coluna

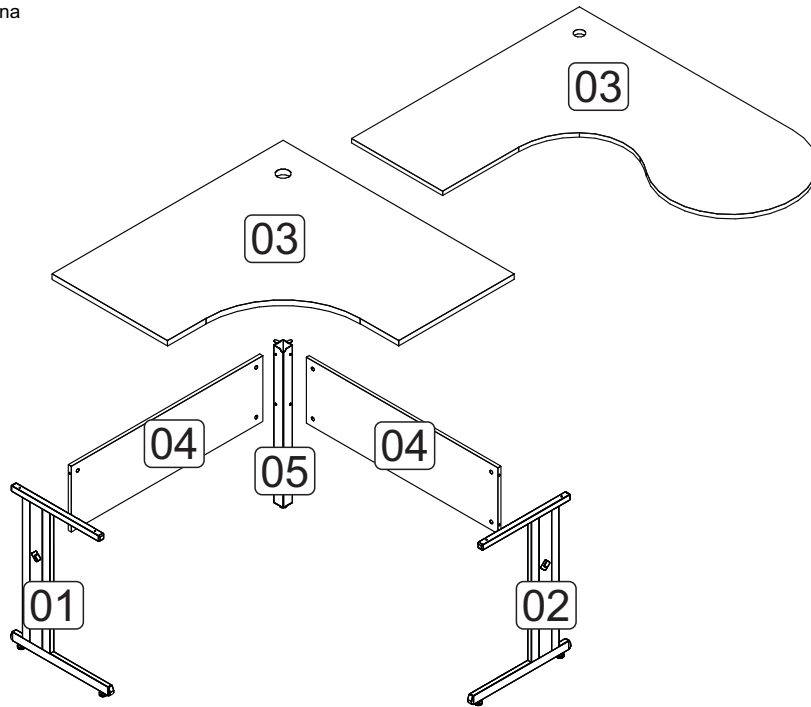

LISTA DE PIEZAS

- 01 - Pié Metal Izquierdo
- 02 - Pié Metal Derecho
- 03 - Tapa
- 04 - Panel Frontal
- 05 - Columna

PARTS IDENTIFICATION

- 01 - Left Foot Metal
- 02 - Right Foot Metal
- 03 - Top
- 04 - Front Panel
- 05 - Column

4

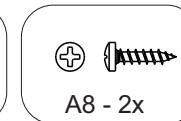
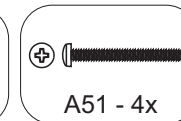
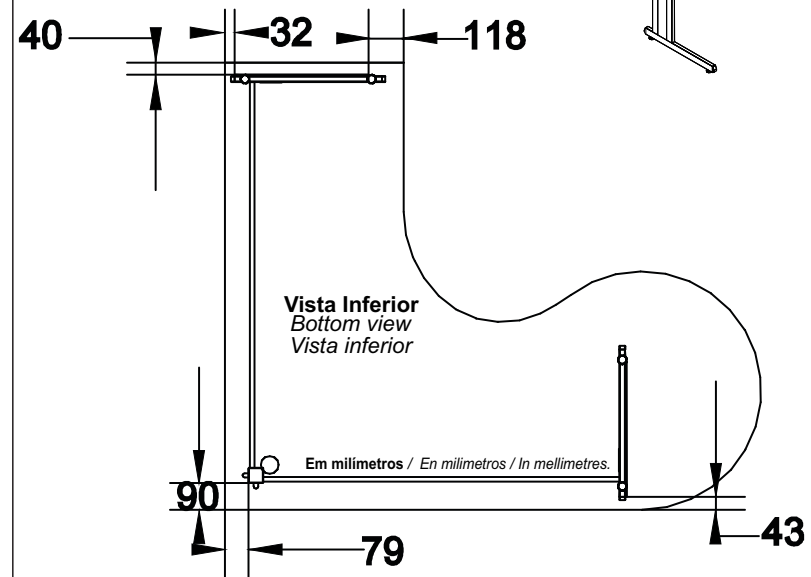
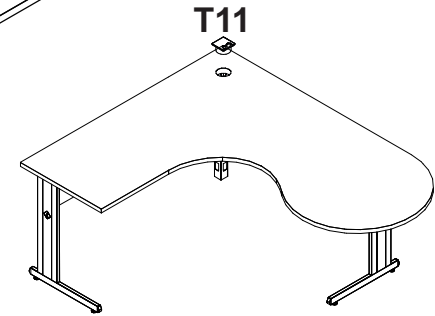
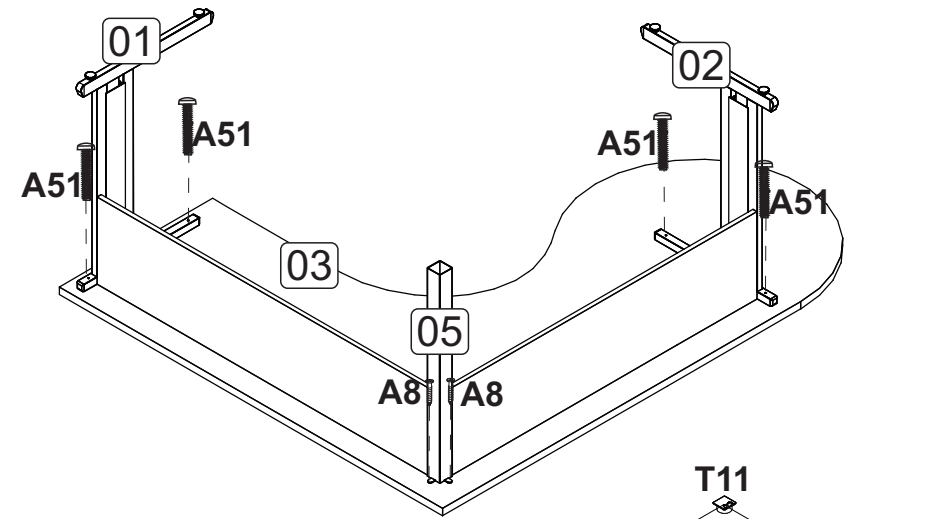

3

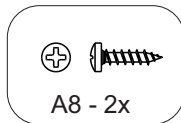
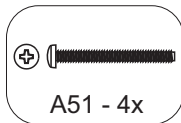
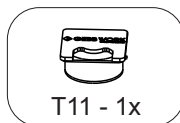
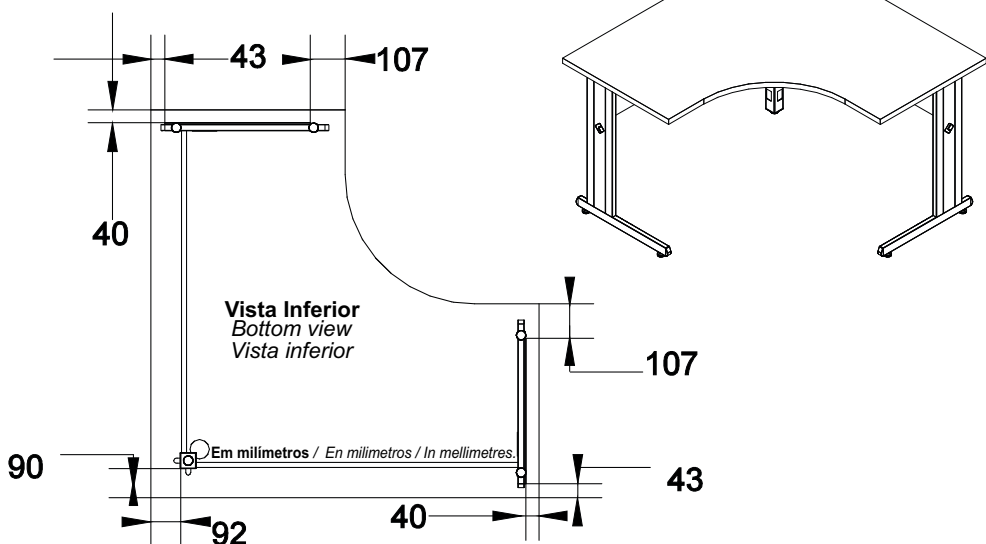
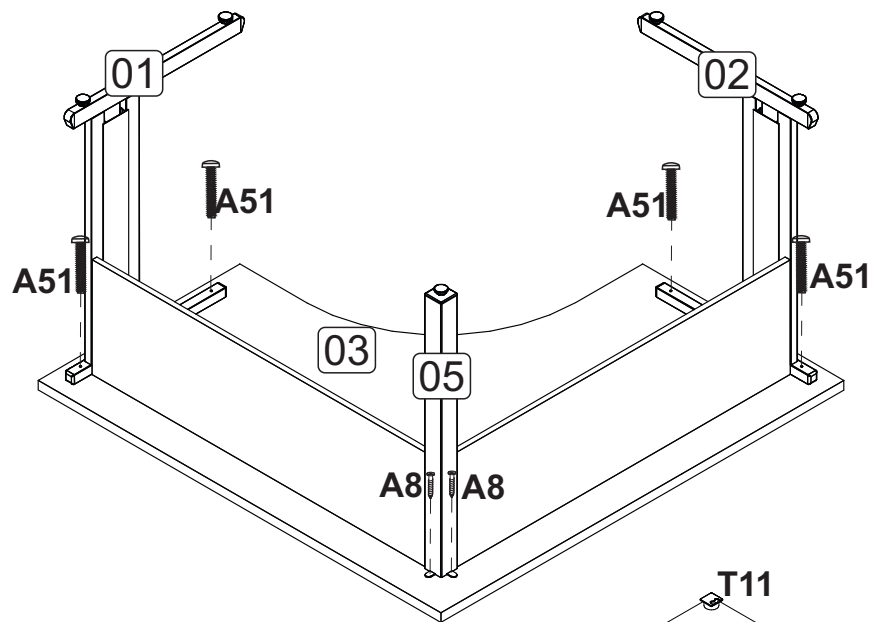

06/08

ACESSÓRIOS ACCESSORIES ACCESORIOS

A8 - PARAF. 4,0x14 CP
2x



A29 - PARAF. MINIFIX
M6x33m 8x



A35 - TAMBOR MINIFIX
8x



A51 - PARAF. M6x40 CP
4x



F1 - TAPA FURO Ø18
8x



L2 - SAPATA PLAST. SEXT.
5x



L5 - BUCHA PLÁSTICA
P/SAPATA 5/16 4x



P10 - PONTEIRA 50X30
PLAST. RETA PRETO 2x



P11 - PONTEIRA 50X50
ROSCA 5/16 PRETO 1x



P15 - PONTEIRA INTERNA
PLAST. 25 X 25 MM 4x

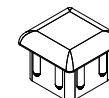

P18 - PONTEIRA 20X40 PLAST.
ABAUADA S/ CALCO 4x



T11 - PASSA CABO
GEBB 60MM 1x



A36 - BUCHA M6x13
4x



03/08

1 PRÉ-MONTAGEM

Preasamblea
Pre-assembly

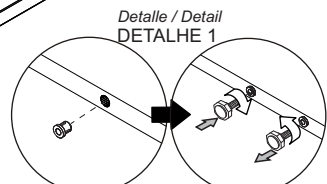
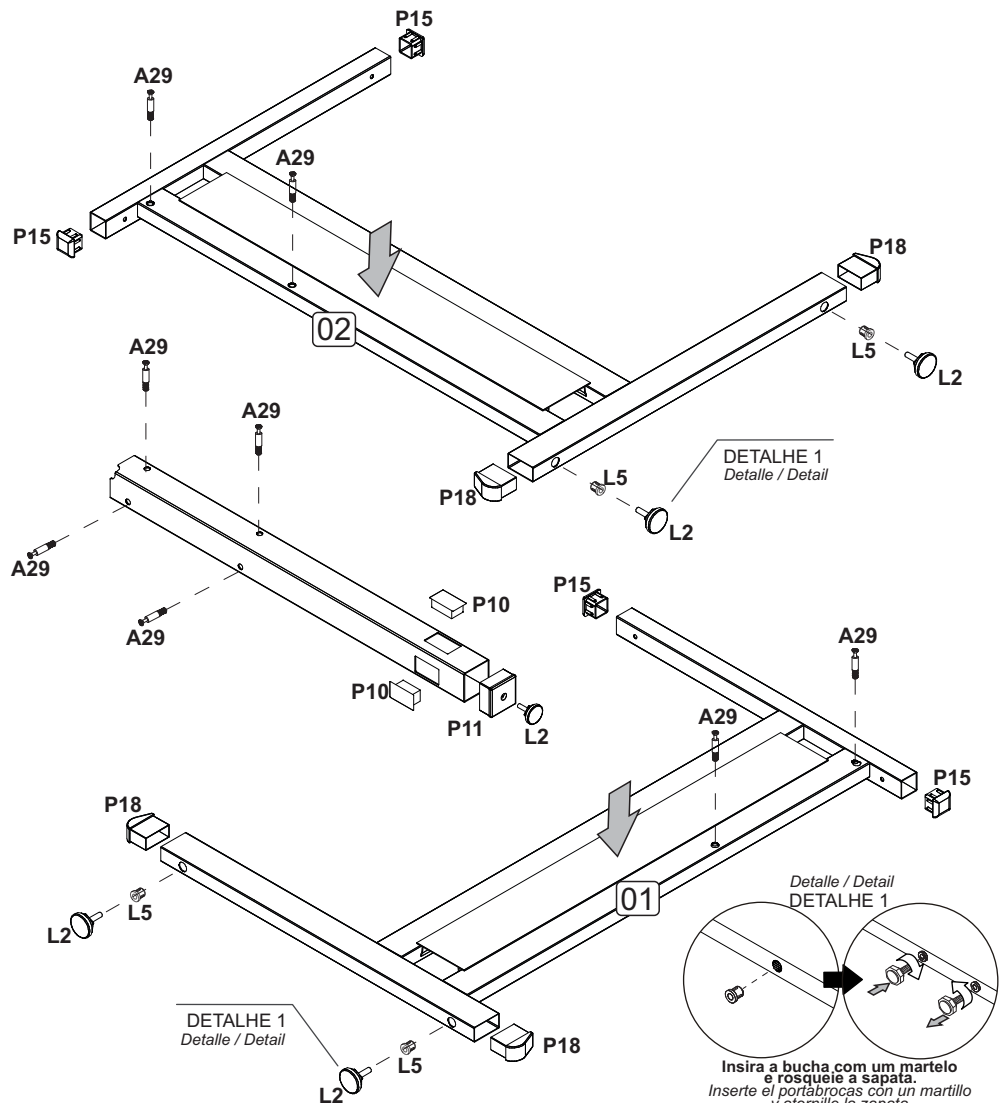

Insira a bucha com um martelo e rosqueie a sapata.
Inserte el portabrocas con un martillo y atornille la zapata.
Insert the chuck with a hammer and screw the shoe.

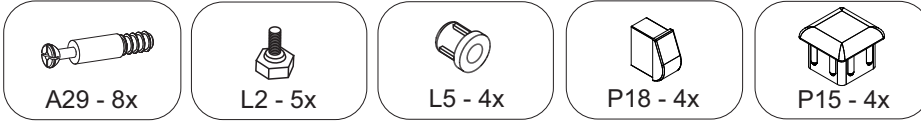
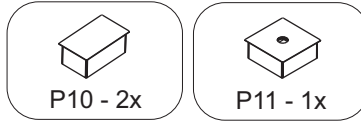

2 MONTAGEM

Armado
Assembly

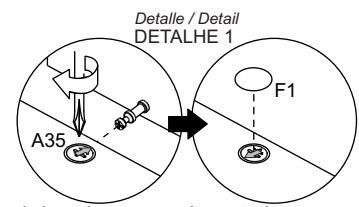
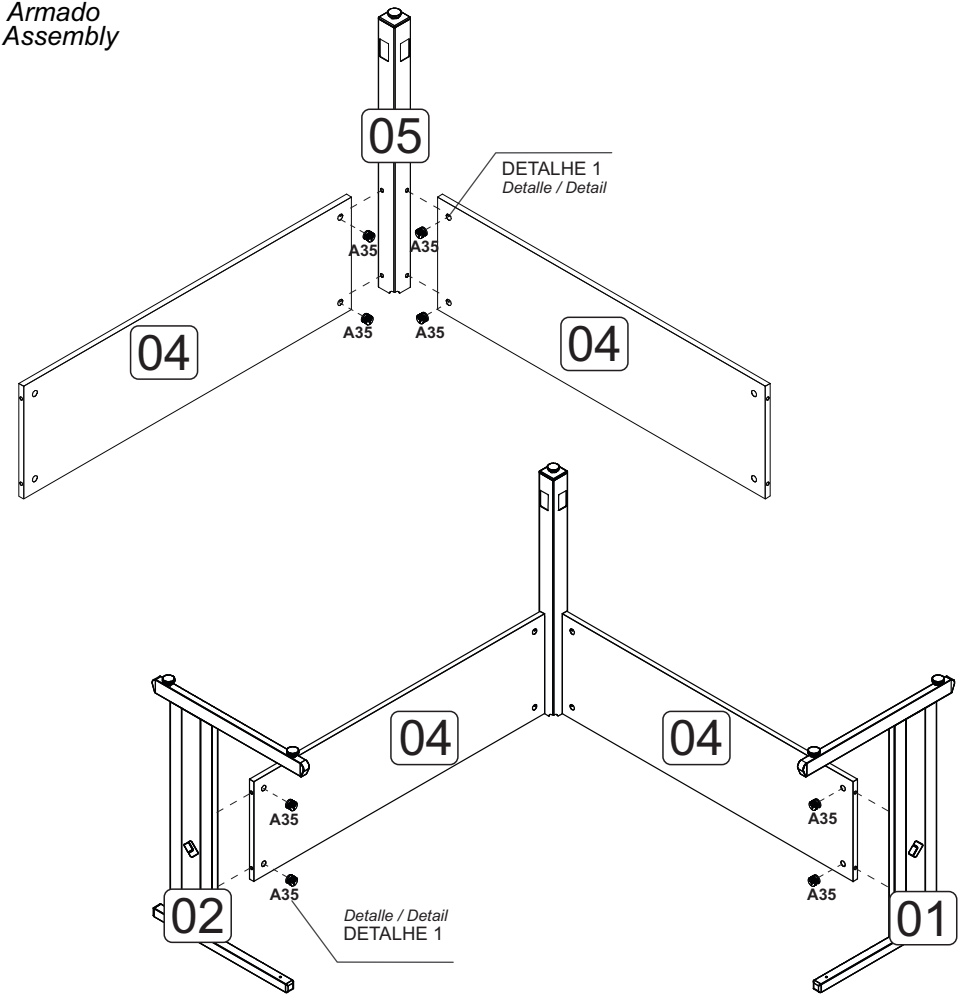

Depois de encaixar as peças coloque o tambor com a sua seta voltada para o parafuso. Para apertar Gire no sentido horário.
Después de colocar las piezas, coloque el tambor con su flecha hacia el tornillo. Para apretar, gire en sentido horario.
After fitting the parts, place the drum with its arrow facing the screw. To tighten, turn clockwise.

