

Capacidade de Carga - Load Capacity - Capacidad de carga

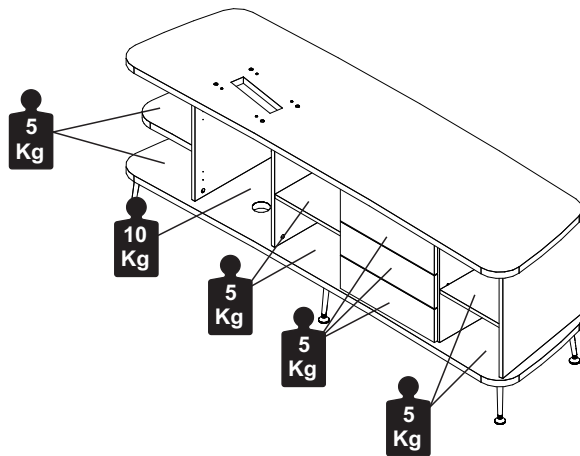
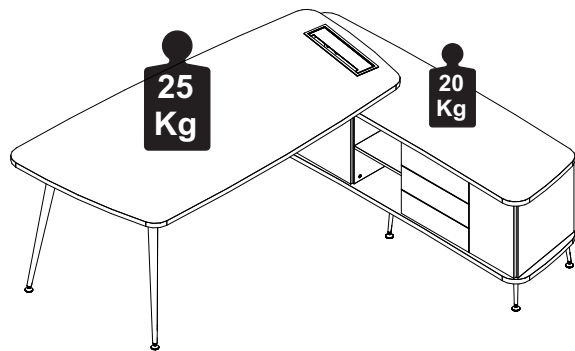

Manutenção e Limpeza

Vidros: pano levemente umedecido com álcool, seguido de pano seco.
Madeiras: pano levemente umedecido com água, seguido de pano seco.
*Nunca utilizar produtos químicos ou abrasivos.

Maintenance and Cleaning

Glasses: cloth lightly moistened with alcohol, followed by dry cloth.
Woods: cloth slightly moistened with water, followed by cloth seco.
*Never use chemicals or abrasives.

Mantenimiento y Limpieza

Vidrios: legeramente humedecido con alcohol, seguido de un paño seco.
Madera: ligeramente humedecido con agua, seguido de un paño seco.
*No utilice nunca productos quimicos o abrasivos.

INSTRUÇÕES DE MONTAGEM ASSEMBLY INSTRUCTIONS INSTRUCCIONES DE MONTAJE

MESA GERENTE COM ARMÁRIO LATERAL MANAGEMENT DESK WITH SIDE CABINET ESCRITORIO DE DIRECCIÓN CON ARMARIO LATERAL

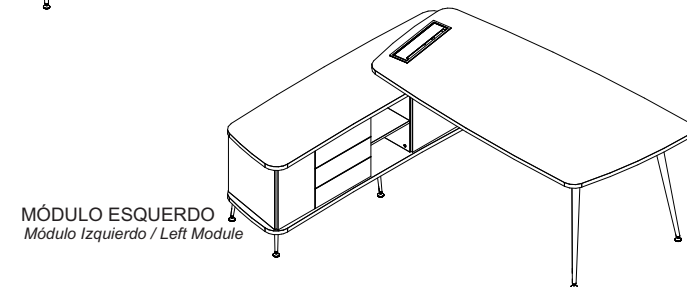
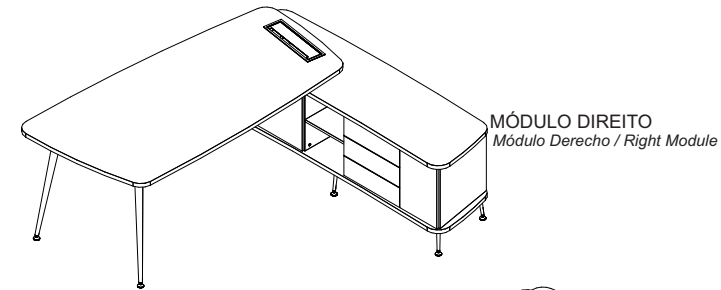

REF. #LXF2218 - LXF2018 - LXF1818
LXF2219 - LXF2019 - LXF1819



MOBILIÁRIO
PARA ESCRITÓRIO

GEBB Work Ind. de Móveis Ltda.
Rua Felix Roman, 190
São Valentin

95709-170 - Bento Gonçalves - RS - Brasil
Fone: (0XX54) 3454-1105 - (0XX54) 3453-1407
Phone: (0XX54) 3454-1105 - (0XX54) 3453-1407

E-mail: pedidos@gebbwork.com.br

www.gebbwork.com.br

WhatsApp: +55 54 99177-8324

São necessários:
Son necesarios:
Are necessary:



*Facilita a montagem / Facilita un montaje / Facilitates mounting.
** Para identificar as peças / Para identificar las partes / To identify the parts.

1 LISTA DE PEÇAS

Parts Identification
Lista de Piezas

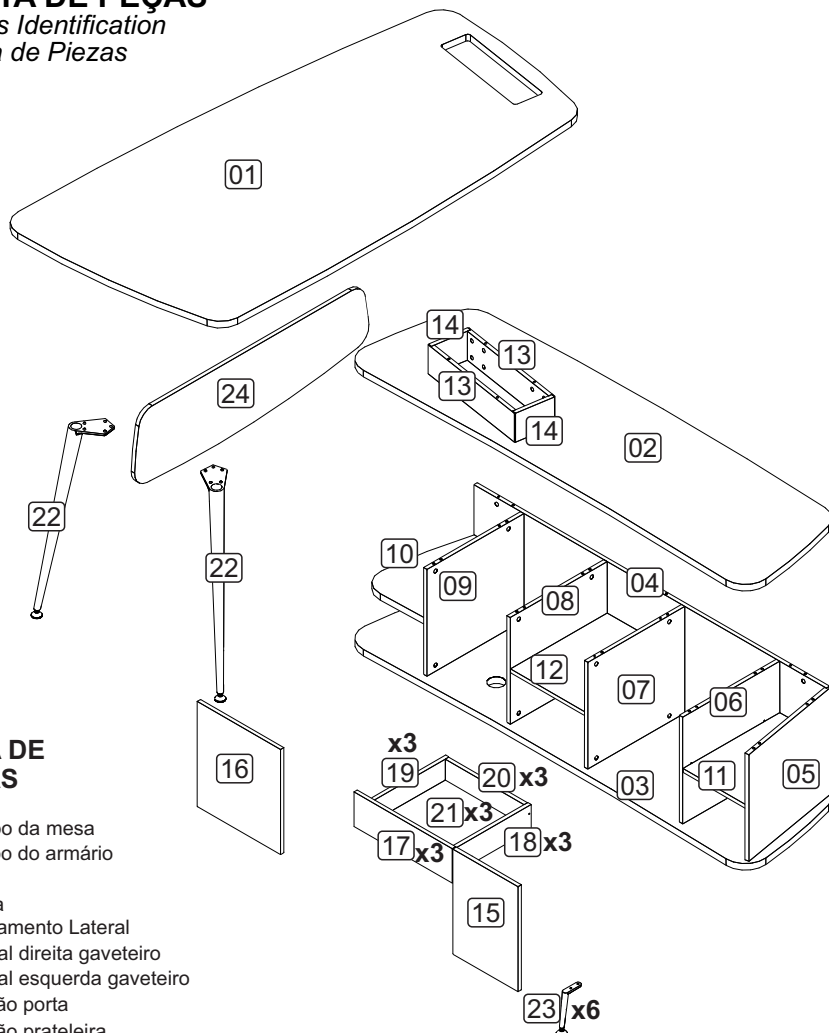

LISTA DE PEÇAS

- 01 - Tampo da mesa
- 02 - Tampo do armário
- 03 - Base
- 04 - Costa
- 05 - Fechamento Lateral
- 06 - Lateral direita gaveteiro
- 07 - Lateral esquerda gaveteiro
- 08 - Divisão porta
- 09 - Divisão prateleira
- 10 - Prateleira angular
- 11 - Prateleira chanfrada
- 12 - Prateleira central
- 13 - Travessa apoio maior
- 14 - Travessa apoio menor
- 15 - Porta menor
- 16 - Porta maior
- 17 - Frente gaveta
- 18 - Lateral de gaveta direita
- 19 - Lateral de gaveta esquerda
- 20 - Costa de gaveta
- 21 - Fundo de gaveta
- 22 - Pé cônico da mesa
- 23 - Pé cônico do armário
- 24 - Painel Frontal

2 Acessórios

Accessories
Accesorios

A29 - PARAF. MINIFIX
M6x33m **8x**

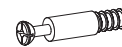

T10 - BASE PASSA CABO
25x60 PTO. **1x**



A6 - PARAF. 3,5x40 CC
6x



A32 - PARAF. MINIFIX
48x

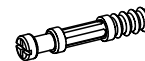

L17 - SAPATA ARTICULADA
ROSCA 5/16 (35MM) **8x**

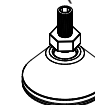

A2 - PARAF. 3,5x14 CC
40x



G7 - DOBRADIÇA 35 C/PISTÃO
RETA BAIXA + CALÇO **4x**



B1 - SUPORTE PRAT.
METÁLICO **4x**



A8 - PARAF. 4,0x14 CP
26x



A62 - PARAF. M6x20 CP
24x



M14 - SUPORTE FRONTAL
MÃO-FRANCESA **2x**



A36 - BUCHA M6x13
36x



D1 - CAVILHA 8x30
70x

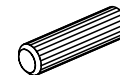

L18 - PULSADOR MAGNÉTICO
2x



A35 - TAMBOR MINIFIX
56x



A99 - BUCHA M6x10
4x

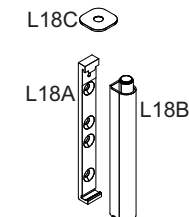

A45 - PARAF. M6x16 CC
4x

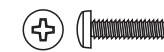

T25 - COLARINHO
1x

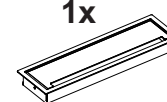

T26 - SUPORTE TOMADAS
1x

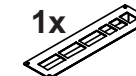

J3 - KIT TRILHO
TELESCÓPICO 350mm
3x



F1 - TAPA FUROS ADESIVO



3 PRÉ-MONTAGEM

Preasamblea
Pre-assembly

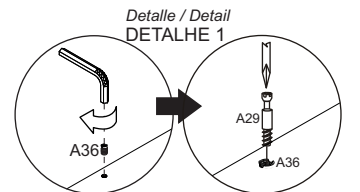
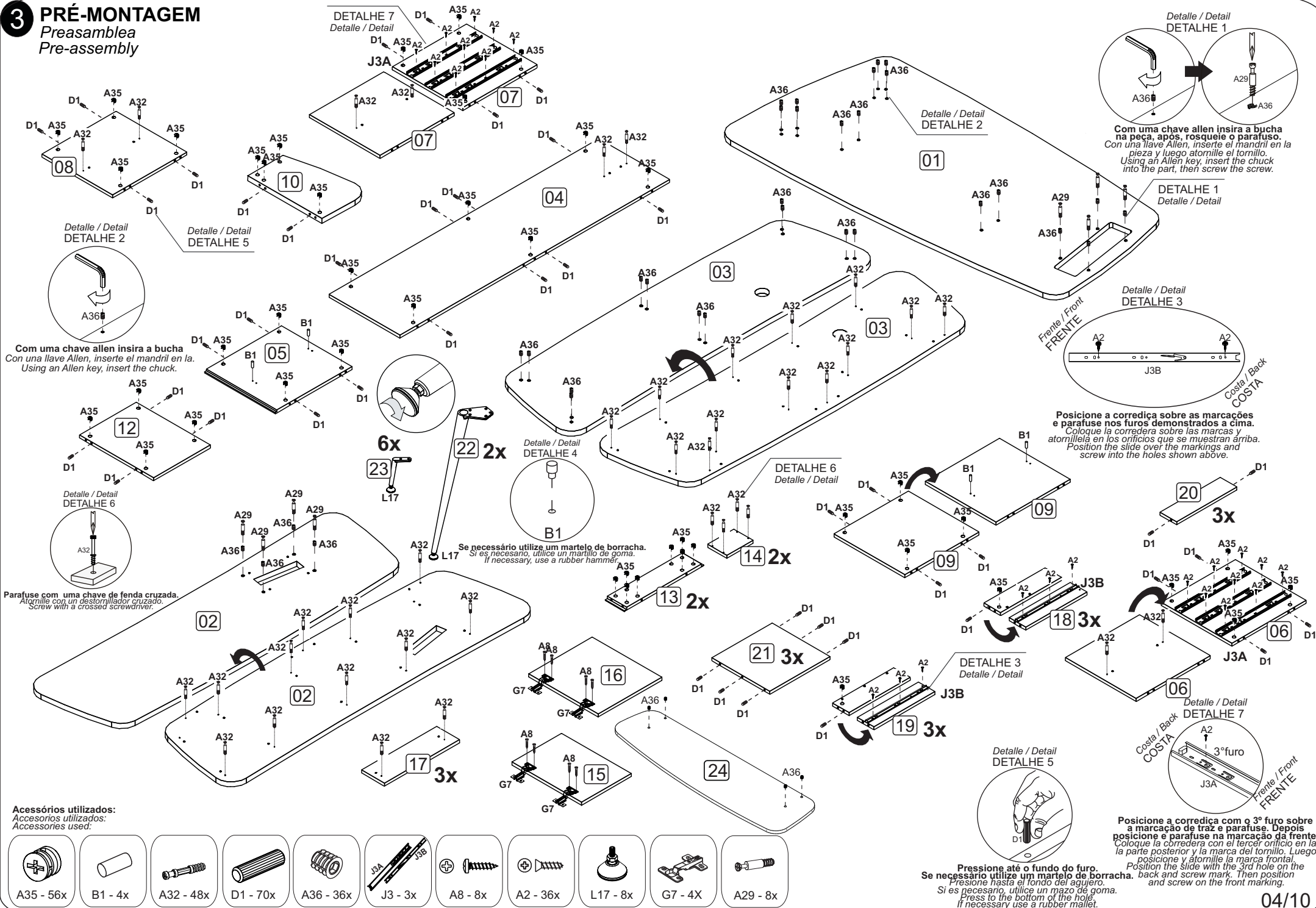

Com uma chave allen insira a bucha na peça, apos, rosqueie o parafuso. Con una llave Allen, inserte el mandril en la pieza y luego atornille el tornillo. Using an Allen key, insert the chuck into the part, then screw the screw.

DETALHE 1
Detalle / Detail

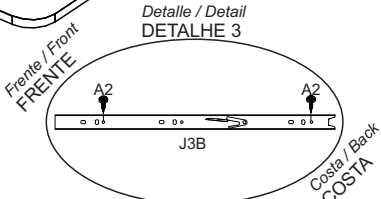

Posicione a corredeira sobre as marcações e parafuse nos furos demonstrados a cima. Coloque la corredera sobre las marcas y atornille en los orificios que se muestran arriba. Position the slide over the markings and screw into the holes shown above.

DETALHE 3
Detalle / Detail

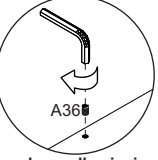

Com uma chave allen insira a bucha Con una llave Allen, inserte el mandril en la. Using an Allen key, insert the chuck.

DETALHE 2
Detalle / Detail

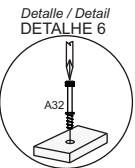

Parafuse com uma chave de fenda cruzada. Atornille con un destornillador cruzado. Screw with a crossed screwdriver.

DETALHE 6
Detalle / Detail

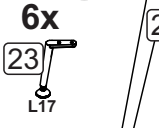

Se necessário utilize um martelo de borracha. Si es necesario, utilice un martillo de goma. If necessary, use a rubber hammer.

DETALHE 4
Detalle / Detail



Pressione até o fundo do furo. Presione hasta el fondo del agujero. Press to the bottom of the hole. If necessary use a rubber mallet.



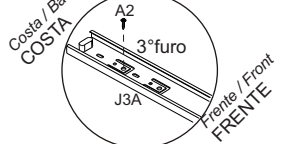







DETALHE 5
Detalle / Detail



Posicione a corredeira com o 3º furo sobre a marcação de traz e parafuse. Depois posicione e parafuse na marcação da frente. Coloque la corredera con el tercer orificio en la parte posterior y la marca del tornillo. Luego posicione y atornille la marca frontal. Position the slide with the 3rd hole on the back and screw mark. Then position and screw on the front marking.

DETALHE 7
Detalle / Detail

Accesórios utilizados:
Accesorios utilizados:
Accessories used:

- 
A35 - 56x
- 
B1 - 4x
- 
A32 - 48x
- 
D1 - 70x
- 
A36 - 36x
- 
J3 - 3x
- 
A8 - 8x
- 
A2 - 36x
- 
L17 - 8x
- 
G7 - 4x
- 
A29 - 8x

4 MONTAGEM

Armado
Assembly

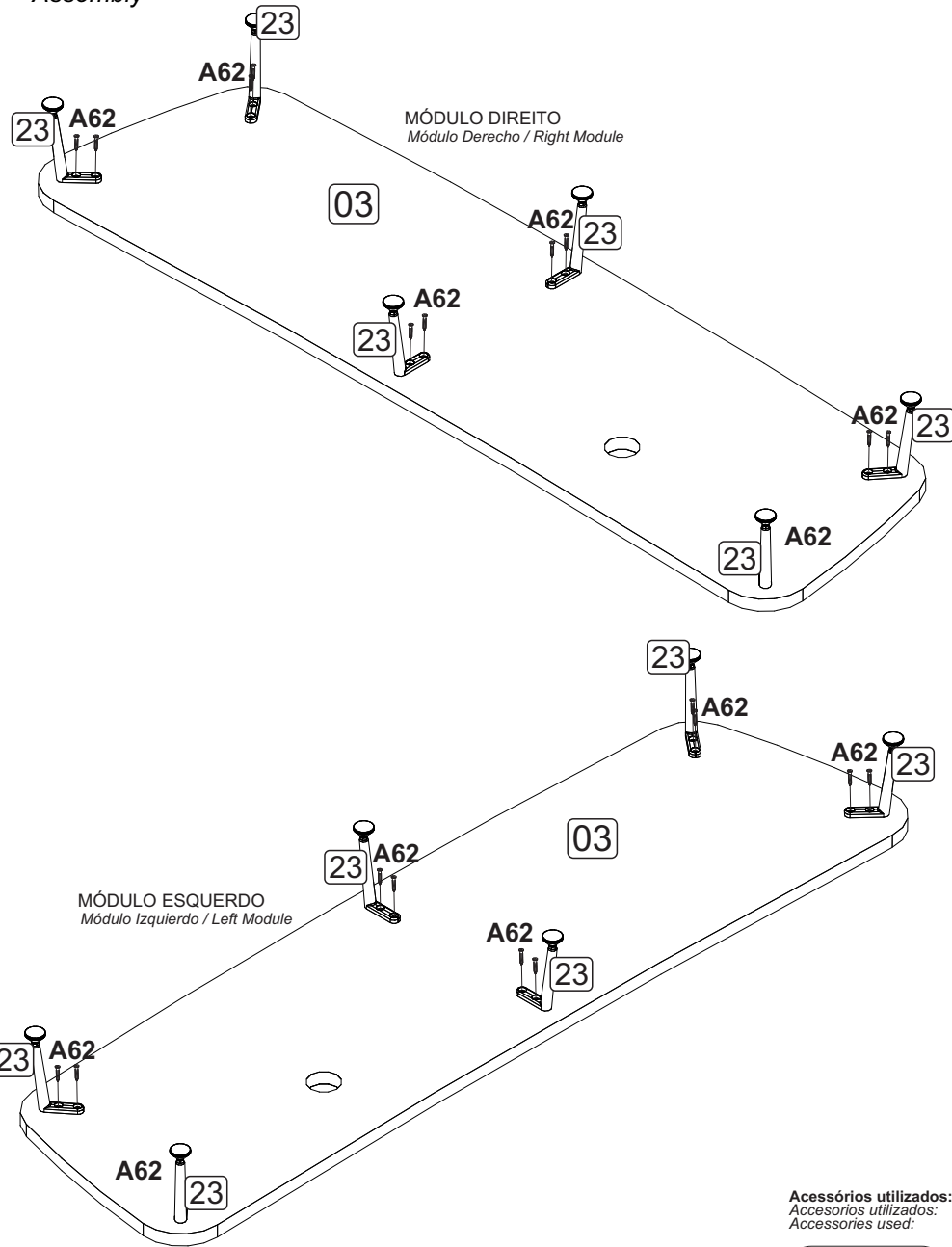

Accesórios utilizados:
Accesorios utilizados:
Accessories used:

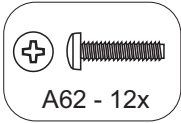

5

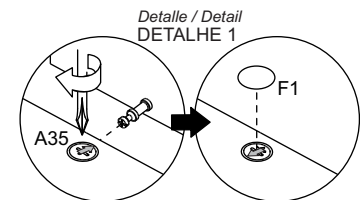
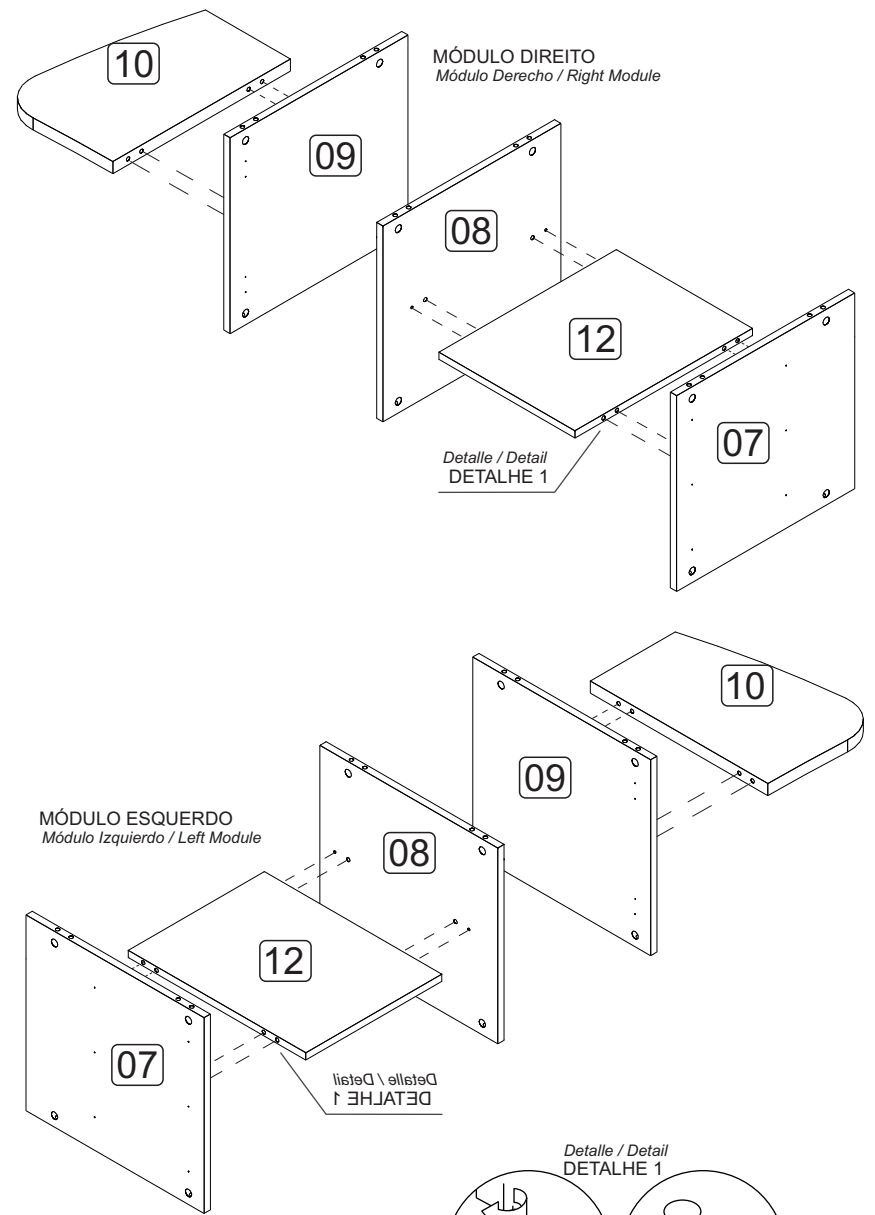

Depois de encaixar as peças coloque o tambor com a sua seta voltada para o parafuso. Para apertar, gire no sentido horário.
Después de colocar las piezas, coloque el tambor con su flecha hacia el tornillo. Para apretar, gire en sentido horario.
After fitting the parts, place the drum with its arrow facing the screw. To tighten, turn clockwise.

6

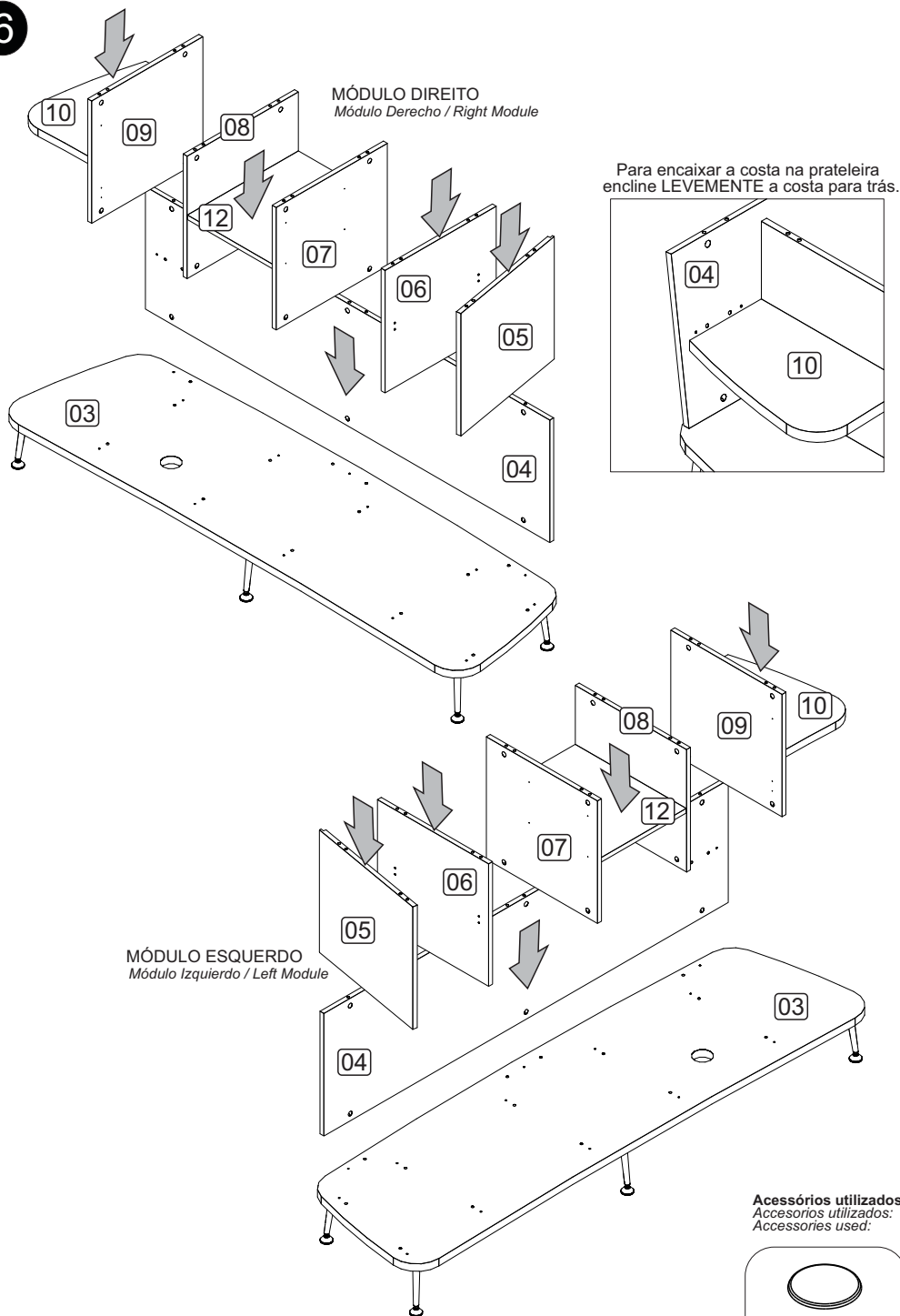

07/15

7

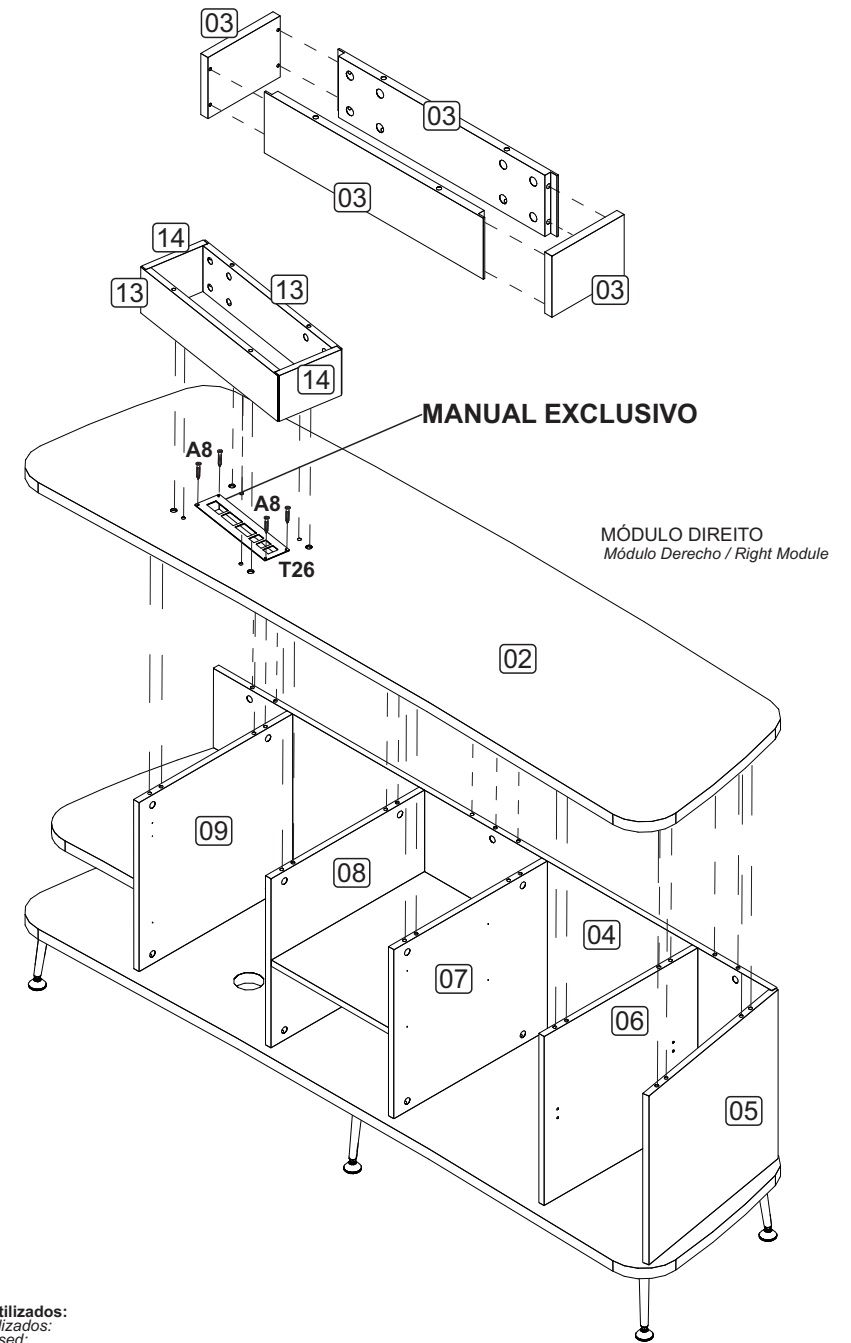

08/15

7

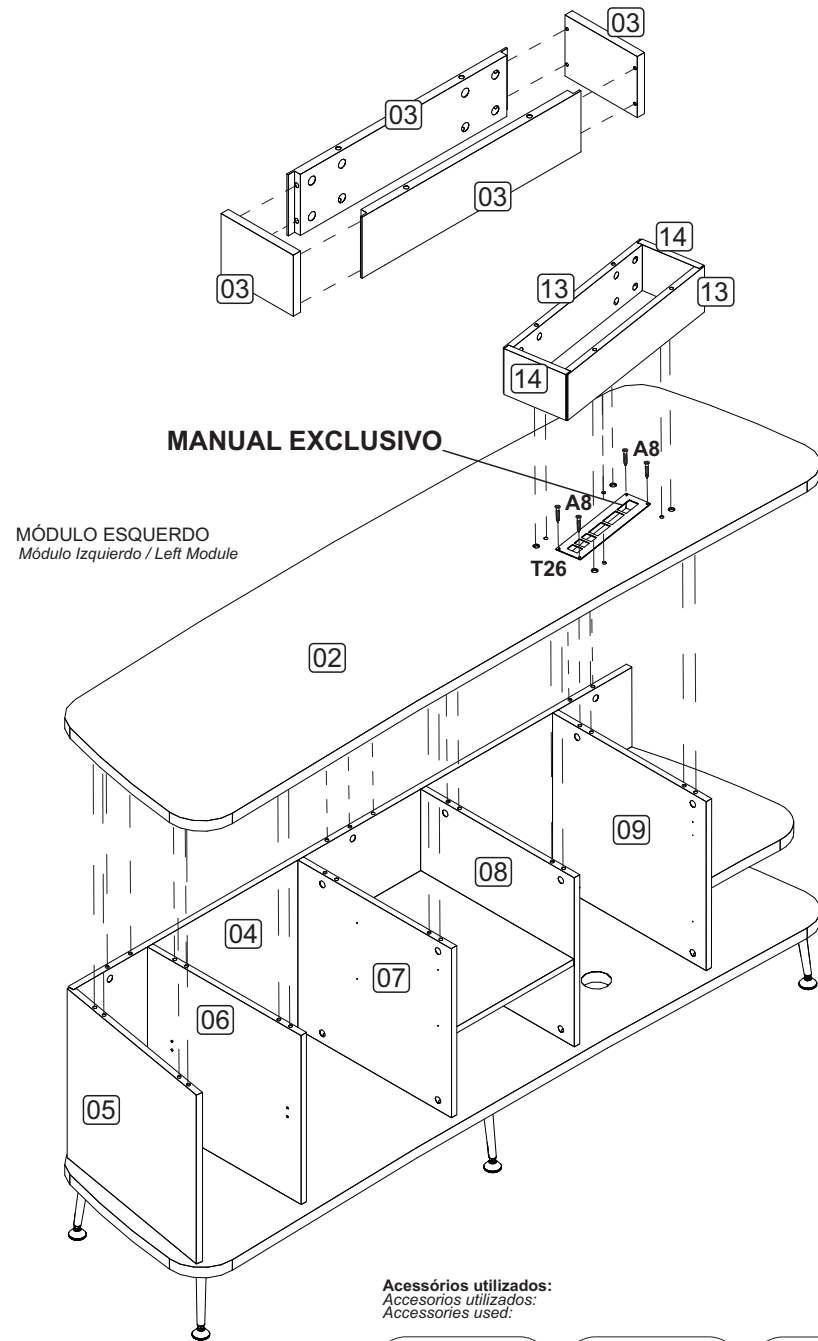

Acessórios utilizados:
Accesorios utilizados:
Accessories used:

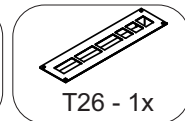
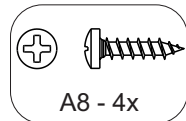
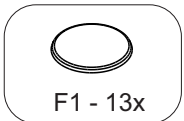

09/15

8

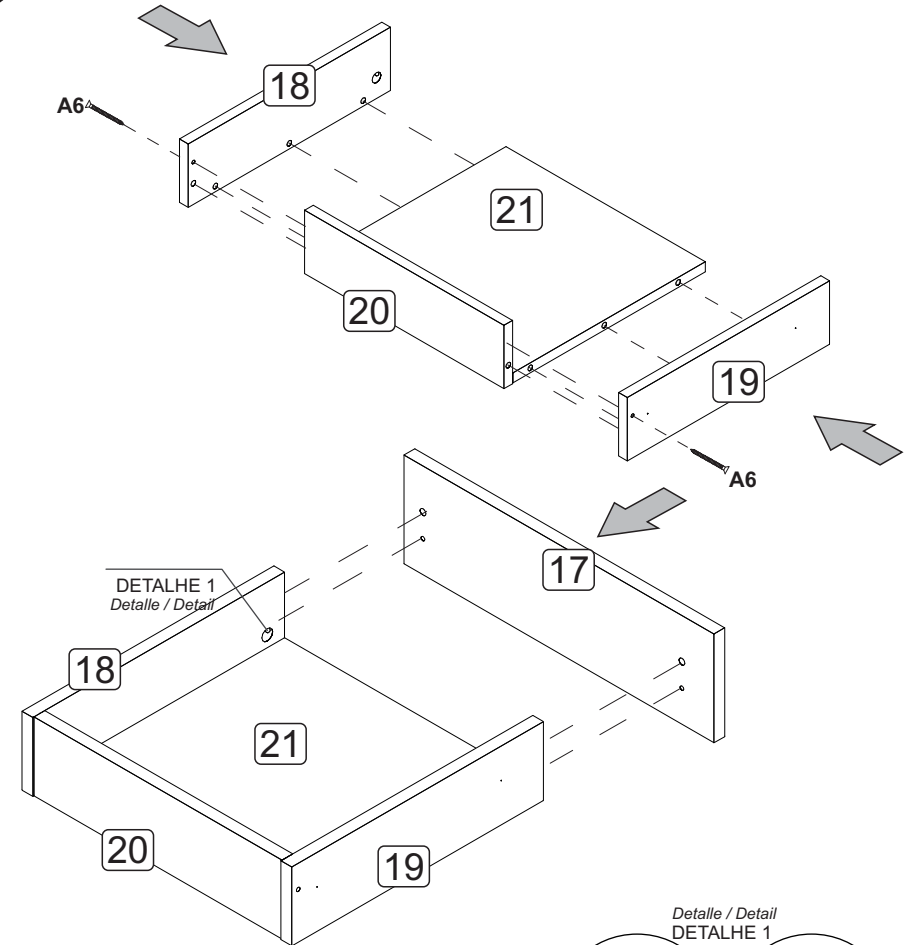

Detalle / Detail
DETALHE 1

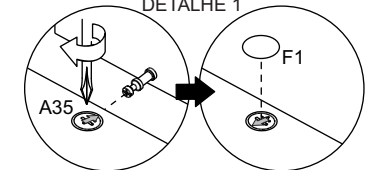

Depois de encaixar as peças coloque o tambor com a sua seta voltada para o parafuso. Para apertar Gire no sentido horário.
Después de colocar las piezas, coloque el tambor con su flecha hacia el tornillo. Para apretar, gire en sentido horario.
After fitting the parts, place the drum with its arrow facing the screw.
To tighten, turn clockwise.

Acessórios utilizados:
Accesorios utilizados:
Accessories used:

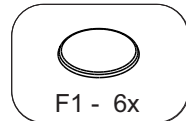
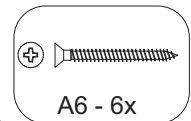

10/15

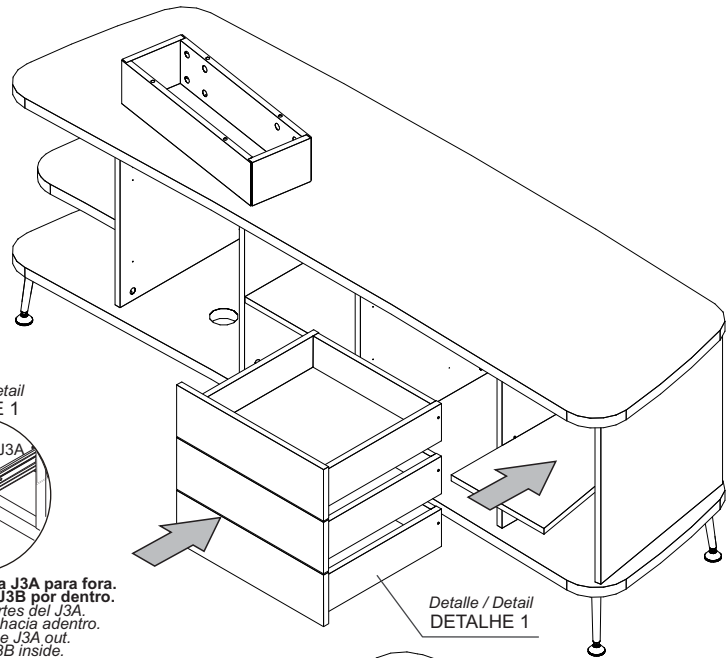

Detalle / Detail
DETALHE 1

Puxe as duas partes da J3A para fora. Em seguida deslize a J3B por dentro.
 Extraiga las dos partes del J3A. Luego deslice el J3B hacia adentro.
 Pull the two parts of the J3A out. Then slide the J3B inside.

Detalle / Detail
DETALHE 1

MÓDULO ESQUERDO
Módulo Izquierdo / Left Module

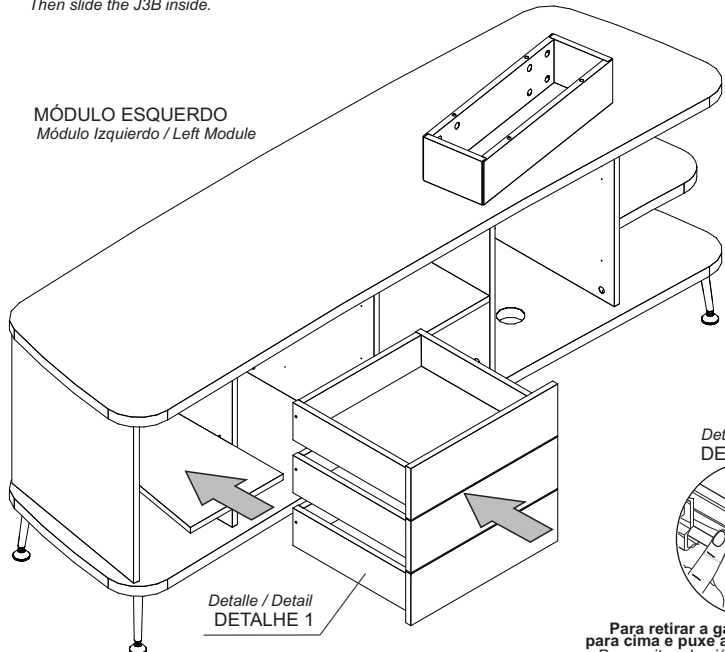

Detalle / Detail
DETALHE 1

Para retirar a gaveta pressione a trava para cima e puxe a gaveta simultaneamente.
 Para quitar el cajón, presione el cierre hacia arriba y tire del cajón simultáneamente.
 To remove the drawer, press the lock upwards and pull the drawer simultaneously.

Detalle / Detail
DETALHE 1

Posicione sobre as marcações.
 Posición en las marcas.
 Position on the markings.

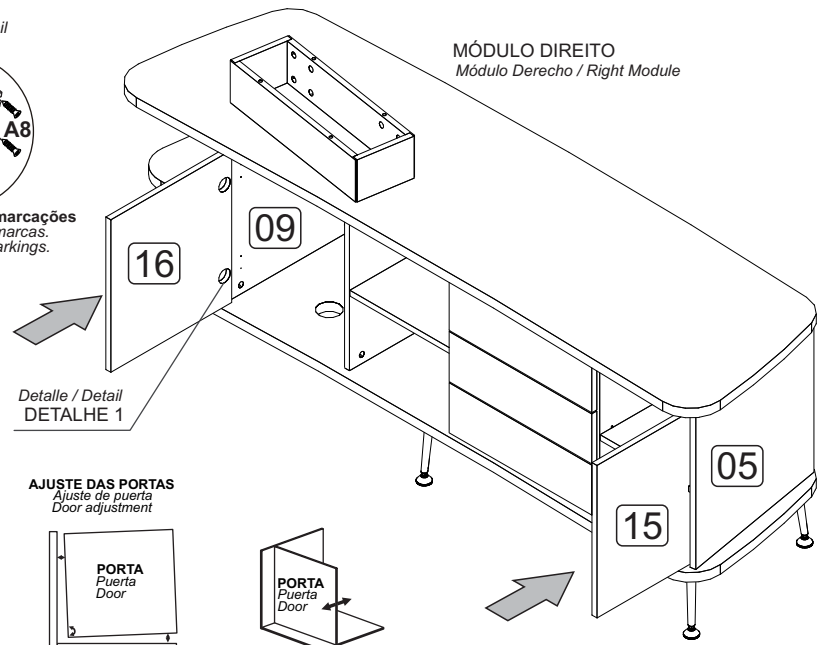

MÓDULO DIREITO
Módulo Derecho / Right Module

Detalle / Detail
DETALHE 1

AJUSTE DAS PORTAS
Ajuste de puerta
Door adjustment

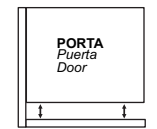

AJUSTE DE ALTURA
Ajuste de altura
Height adjustment



AJUSTE INTERNO
Ajuste interno
Internal adjustment



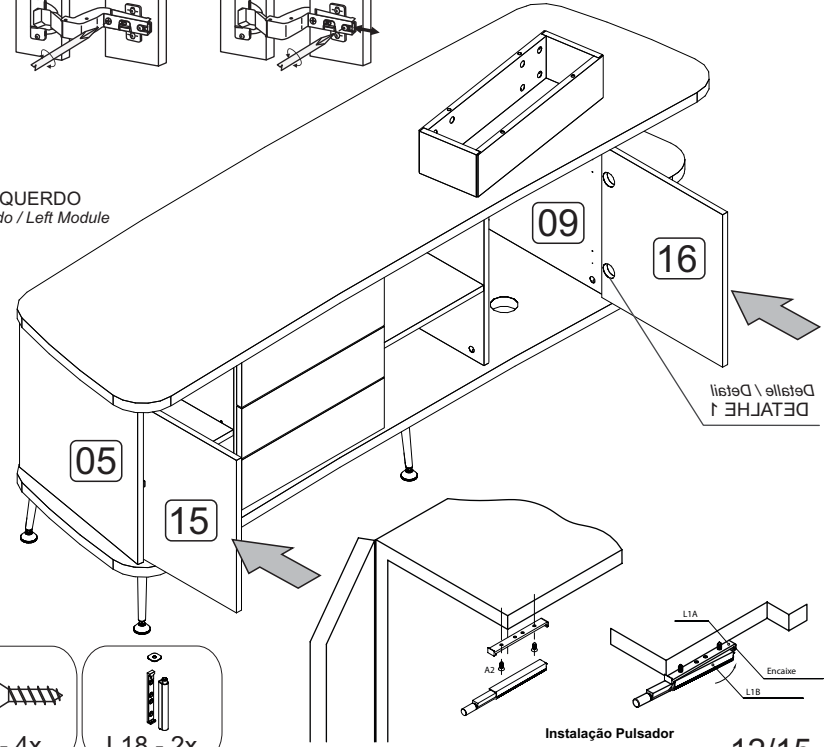

AJUSTE DE PROFUNDIDADE
Ajuste de profundidad
Depth adjustment

MÓDULO ESQUERDO
Módulo Izquierdo / Left Module



Detalle / Detail
DETALHE 1

Accesórios utilizados:
 Accesorios utilizados:
 Accessories used:

- 
 A8 - 12x
- 
 A2 - 4x
- 
 L18 - 2x

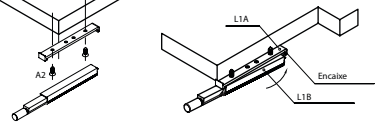

Instalação Pulsador

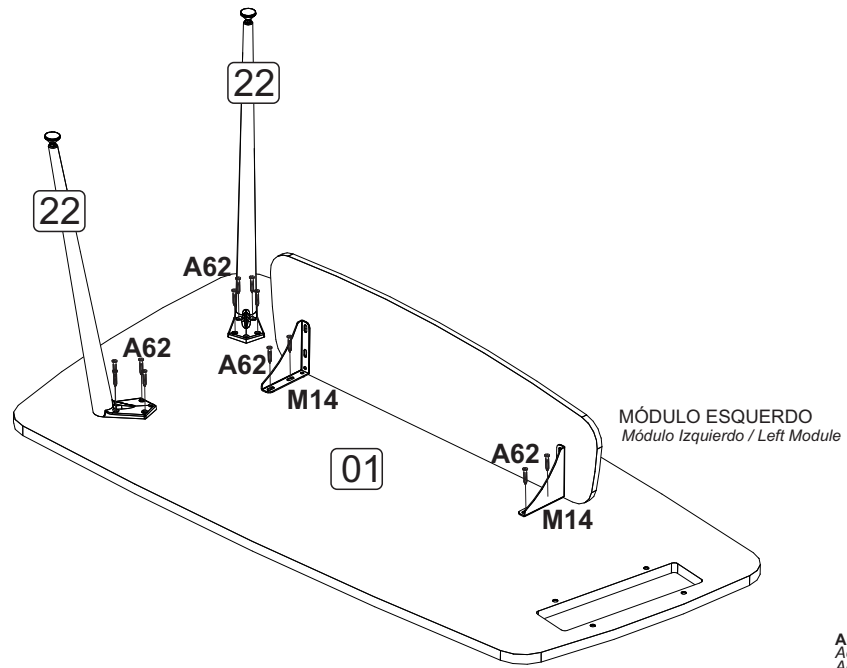
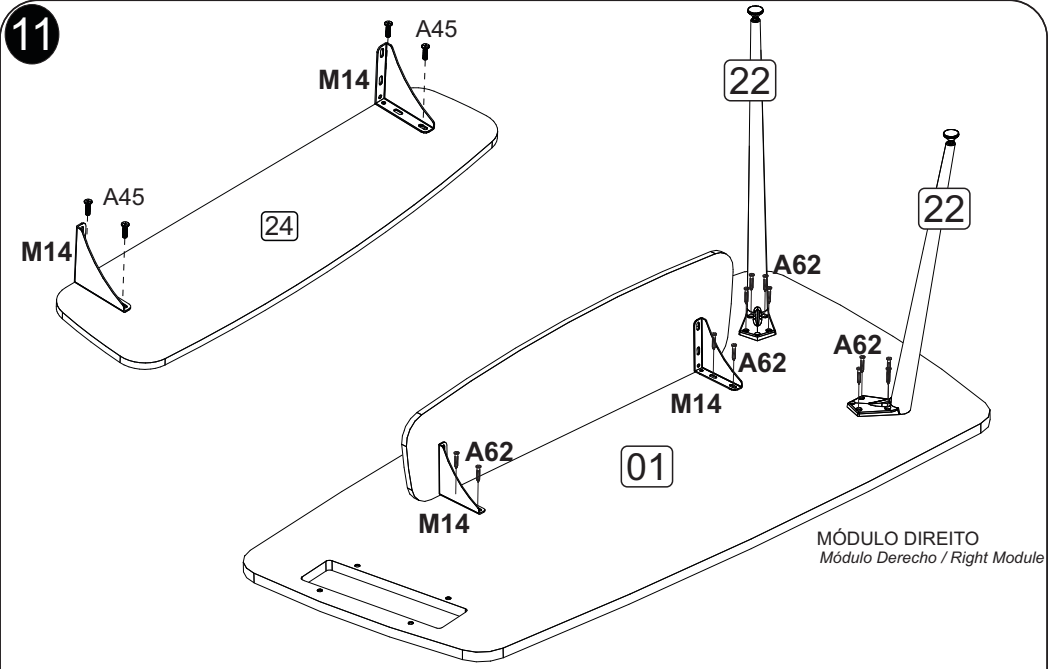

Accesórios utilizados:
Accesorios utilizados:
Accessories used:

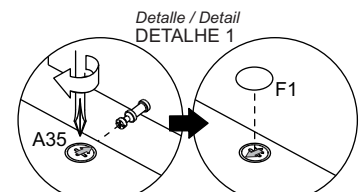
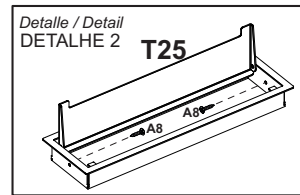
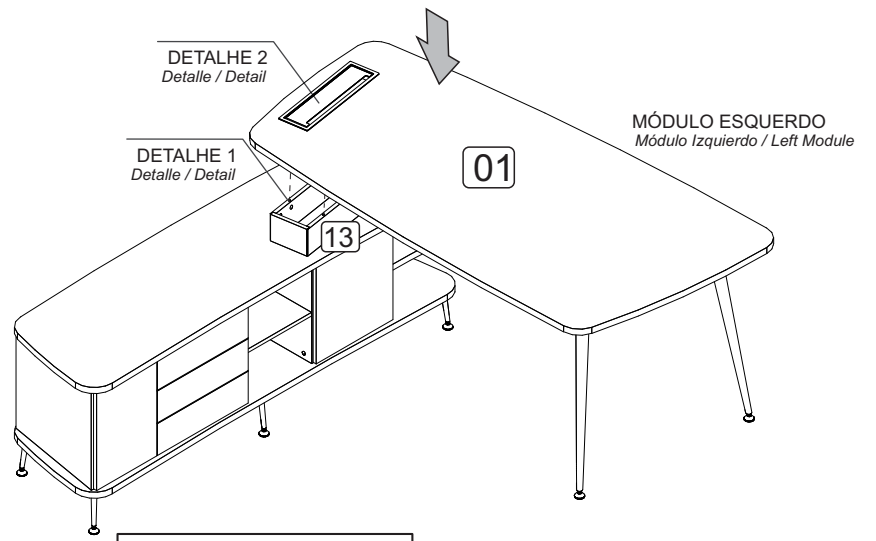
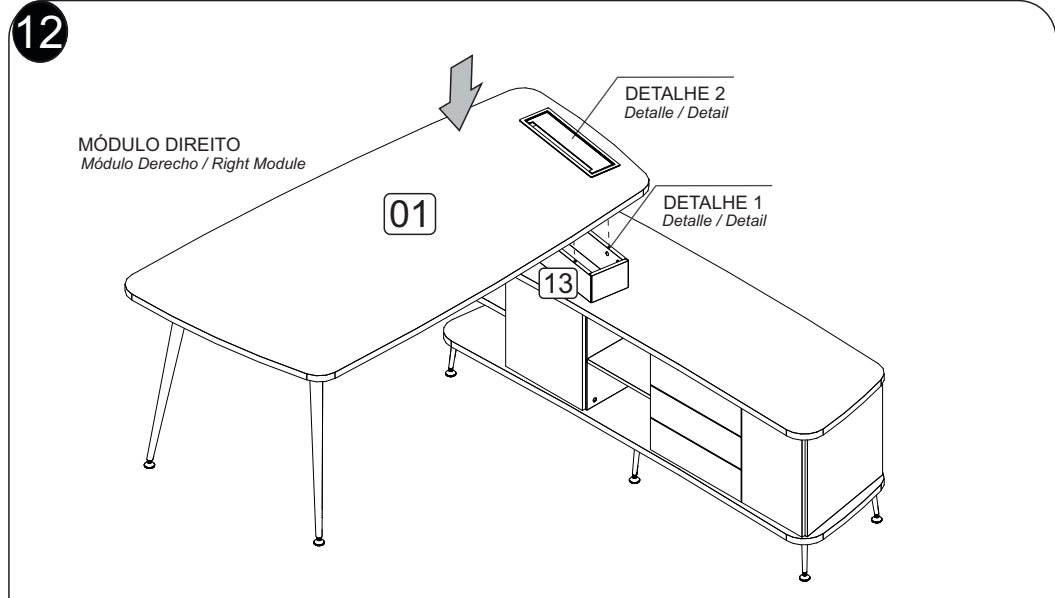
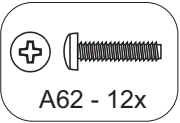
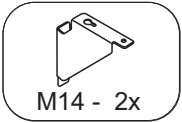
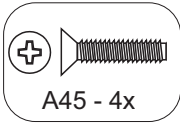

Accesórios utilizados:
Accesorios utilizados:
Accessories used:

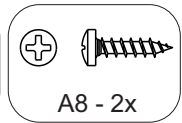
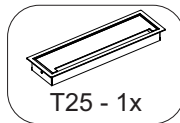

Depois de encaixar as peças coloque o tambor com a sua seta voltada para o parafuso. Para apertar Gire no sentido horário.
Después de colocar las piezas, coloque el tambor con su flecha hacia el tornillo. Para apretar, gire en sentido horario.
After fitting the parts, place the drum with its arrow facing the screw. To tighten, turn clockwise.