

## Capacidade de Carga - Load Capacity - Capacidad de carga

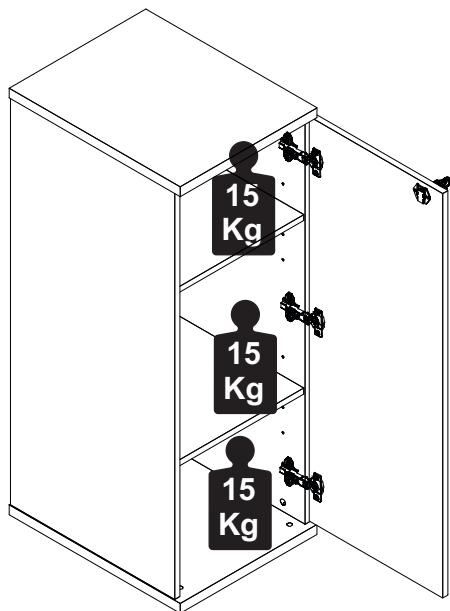

### Manutenção e Limpeza

Vidros: pano levemente umedecido com álcool, seguido de pano seco.  
Madeiras: pano levemente umedecido com água, seguido de pano seco.  
\*Nunca utilizar produtos químicos ou abrasivos.

### Maintenance and Cleaning

Glasses: cloth lightly moistened with alcohol, followed by dry cloth.  
Woods: cloth slightly moistened with water, followed by cloth seco.  
\*Never use chemicals or abrasives.

### Mantenimiento y Limpieza

Vidrios: legeramente humedecido con alcohol, seguido de un paño seco.  
Madera: ligeramente humedecido con agua, seguido de un paño seco.  
\*No utilice nunca productos quimicos o abrasivos.

## INSTRUÇÕES DE MONTAGEM ASSEMBLY INSTRUCTIONS INSTRUCCIONES DE MONTAJE

### ARMÁRIO MÉDIO MEDIUM CUPBOARD ARMARIO MEDIANO

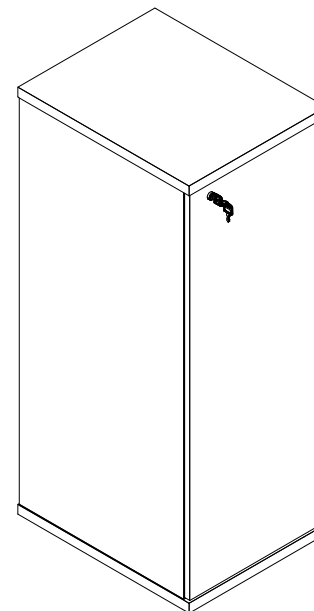

1 P.



15mim

REF. #LXP4013

 **Gebbwork**

MOBILIÁRIO  
PARA ESCRITÓRIO

GEBB Work Ind. de Móveis Ltda.  
Rua Felix Roman, 190  
São Valentin

95709-170 - Bento Gonçalves - RS - Brasil  
Fone: (0XX54) 3454-1105 - (0XX54) 3453-1407  
Phone: (0XX54) 3454-1105 - (0XX54) 3453-1407

E-mail: [pedidos@gebbwork.com.br](mailto:pedidos@gebbwork.com.br)  
[www.gebbwork.com.br](http://www.gebbwork.com.br)

WhatsApp: +55 54 99177-8324

## LISTA DE PEÇAS

- 01 - Lateral Esquerda
- 02 - Lateral Direita
- 03 - Tampo
- 04 - Base
- 05 - Prateleira Movei
- 06 - Costa
- 07 - Porta

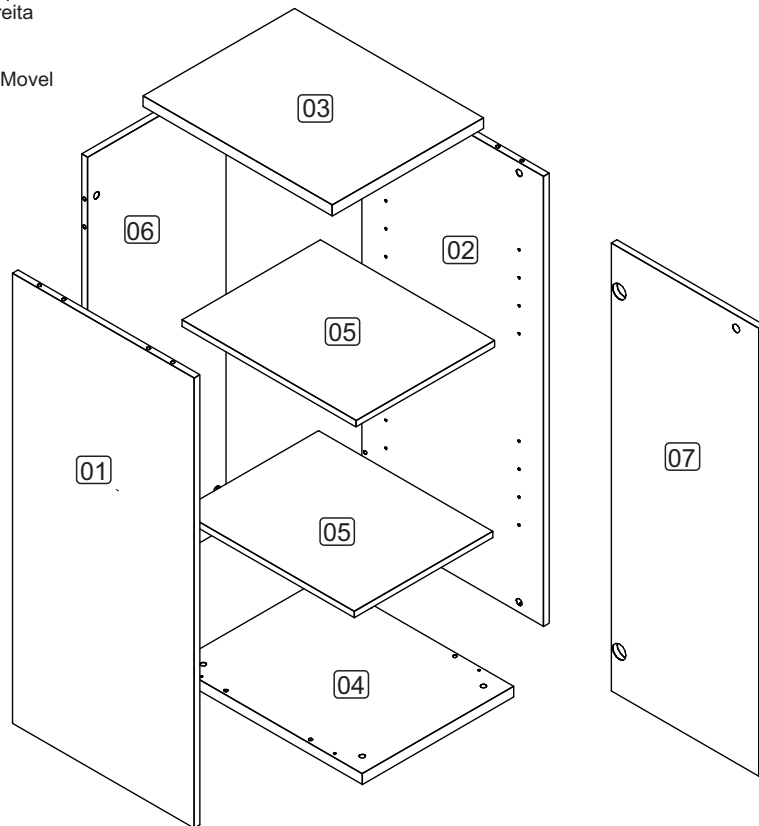

## LISTA DE PIEZAS

- 01 - Lateral Izquierda
- 02 - Lateral Derecha
- 03 - Tapa
- 04 - Base
- 05 - Repisa Fija
- 06 - Revés
- 07 - Puerta

## PARTS IDENTIFICATION

- 01 - Left Side
- 02 - Right Side
- 03 - Top
- 04 - Base
- 05 - Fixed Shelf
- 06 - Back
- 07 - Door

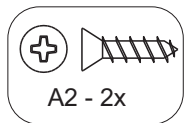
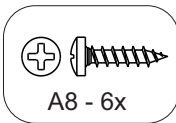
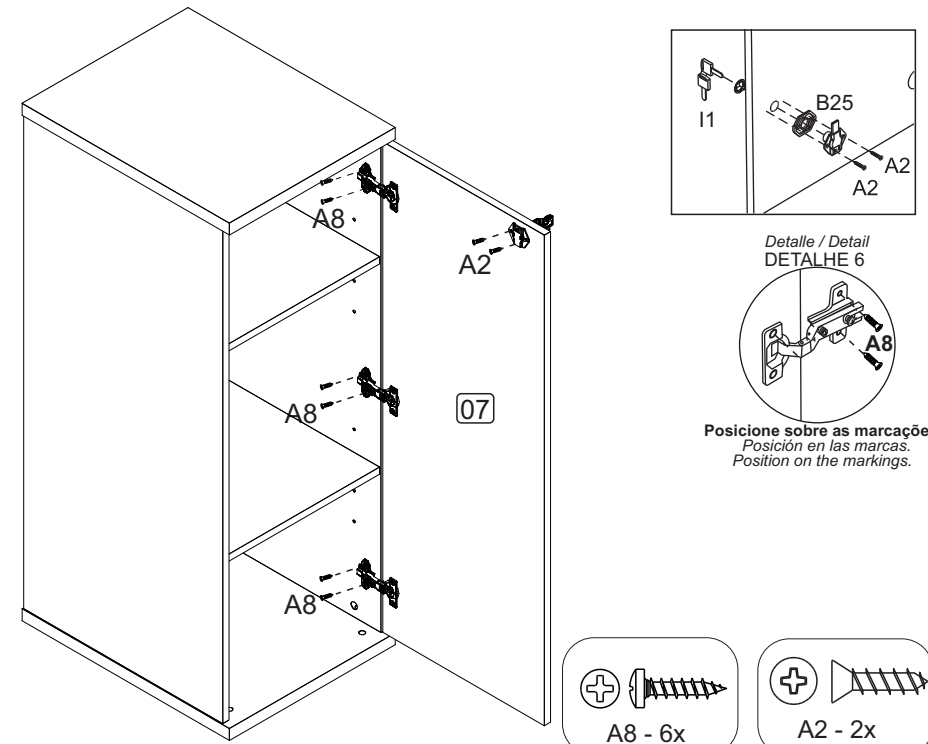

Colocar pulsador magnético ao tampo..  
olhar manual exclusivo do pulsador.

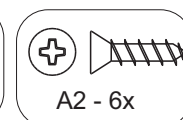
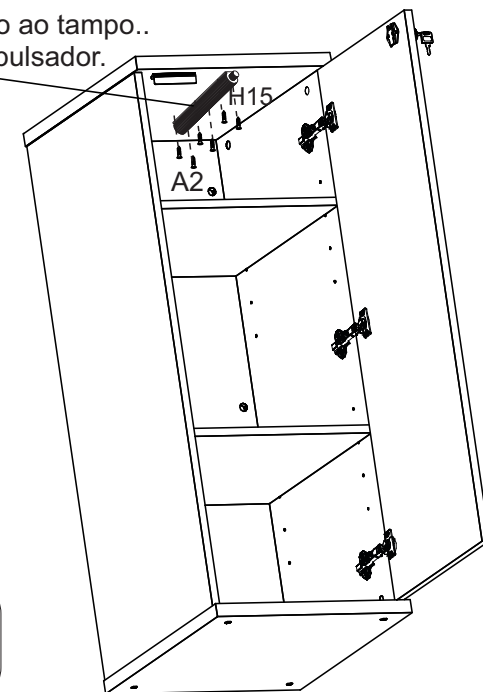

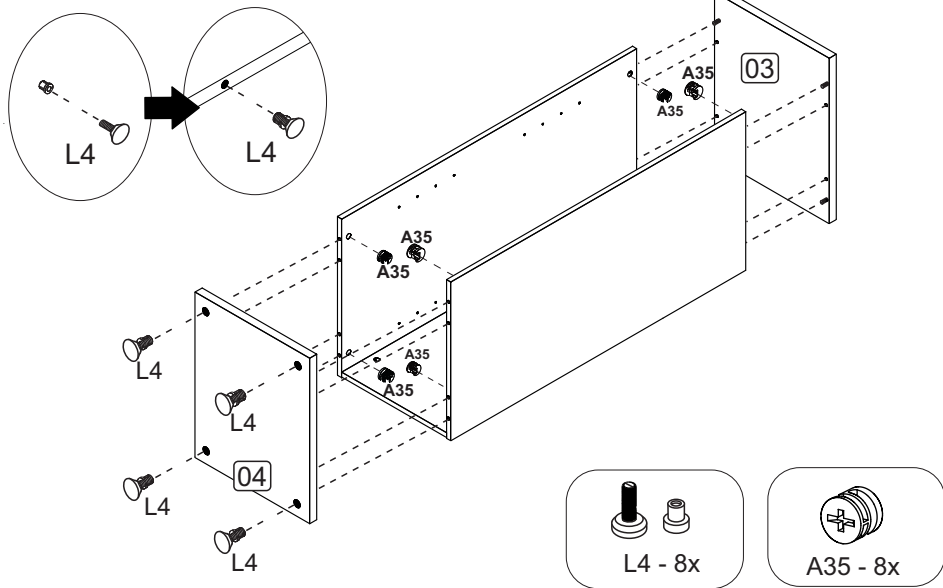

Posicione as prateleiras sobre os suportes metálicos.

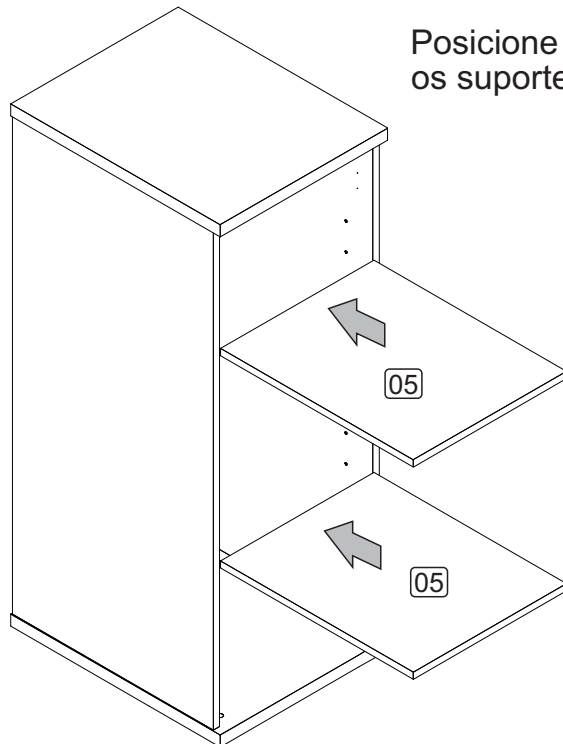

## ACESSÓRIOS ACCESSORIES ACCESORIOS

A2 - PARAF. 3,5x14 CC  
**8x**



A8 - PARAF. 4,0x14 CP  
**18x**



A35 - TAMBOR  
MINIFIX **14x**



A32 - PARAF. MINIFIX  
**14x**

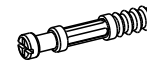

I1 - FECHADURA P/GAV.  
**1x**



D1 - CAVILHA 8x30  
**12x**

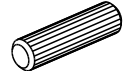

G3 - DOBRADIÇA 35 C/PISTÃO  
BAIXA + CALÇO **3x**

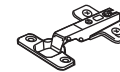

B25 - SEPARADOR PARA  
FECHADURA **1x**



F1 - TAPA FURO Ø18  
**18x**



M1 - CHAPA L 2 FUROS  
OBL 42x17x0,9mm ZB **1x**



B1 - SUPORTE PRAT.  
METÁLICO **8x**



H15-PULSADOR MAGNETICO  
**1x**



L4 - DESLIZADOR  
P/ARMÁRIO **4x**



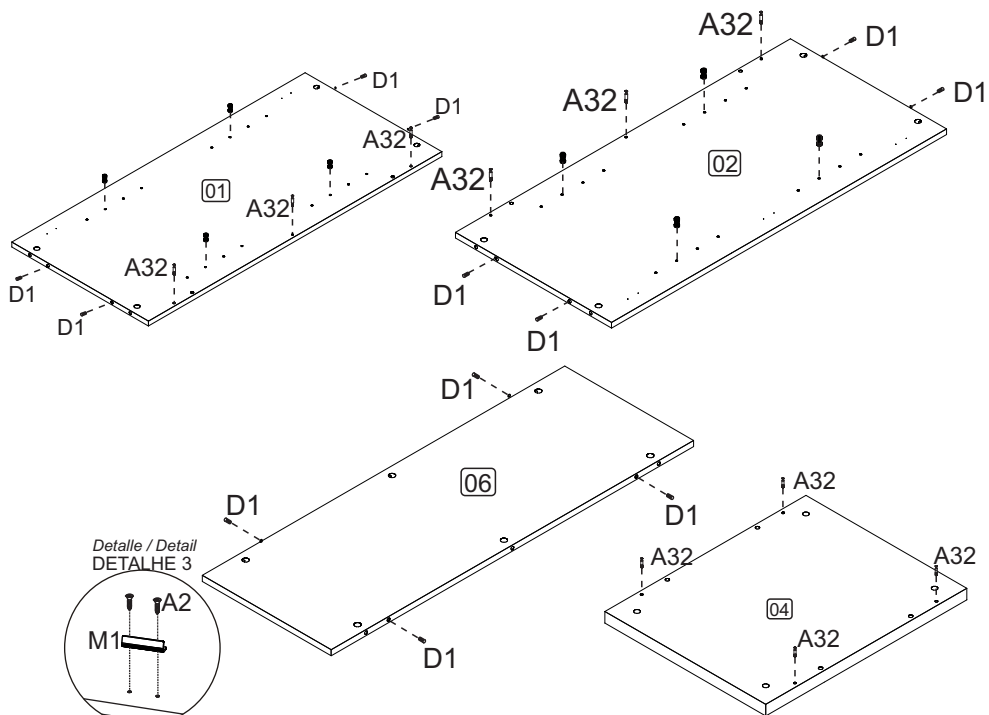

Detalhe / Detail  
DETALHE 3

Posicione a chapa sobre a marcação com sua aba voltada para fora.  
Coloque la placa sobre la marca y con su solapa hacia afuera.  
Position the plate over the marking and with its flap facing outward.

Detalhe / Detail  
DETALHE 4

Monte a dobradiça e o calço.  
Após fixe na porta.  
Ensamble la bisagra y la cuña.  
Después de arreglar la puerta.  
Assemble the hinge and the shim.  
After fix on the door.

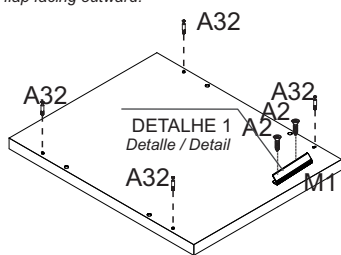

DETALHE 1  
Detalle / Detail

Monte a dobradiça e o calço.  
Após fixe na porta.  
Ensamble la bisagra y la cuña.  
Después de arreglar la puerta.  
Assemble the hinge and the shim.  
After fix on the door.

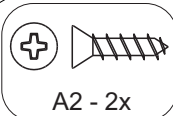
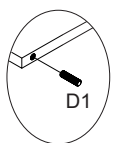
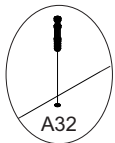
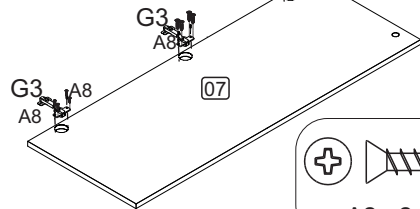

04/08

M1 - 1x

D1 - 12x

A8 - 12x

G3 - 3x

A32 - 14x

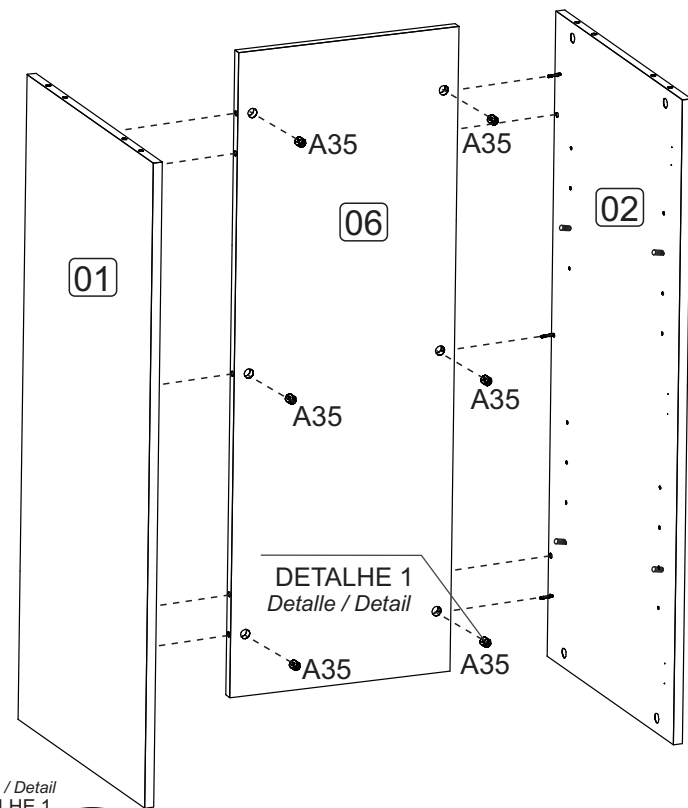

DETALHE 1  
Detalle / Detail

Detalhe / Detail  
DETALHE 1

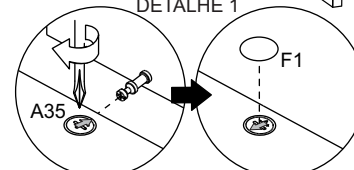

Depois de encaixar as peças coloque o tambor com a sua seta voltada para o parafuso. Para apertar Gire no sentido horário.  
Después de colocar las piezas, coloque el tambor con su flecha hacia el tornillo. Para apretar, gire en sentido horario.  
After fitting the parts, place the drum with its arrow facing the screw. To tighten, turn clockwise.

A35 - 6x

F1 - 6x

05/08