

## Capacidade de Carga - Load Capacity - Capacidad de carga

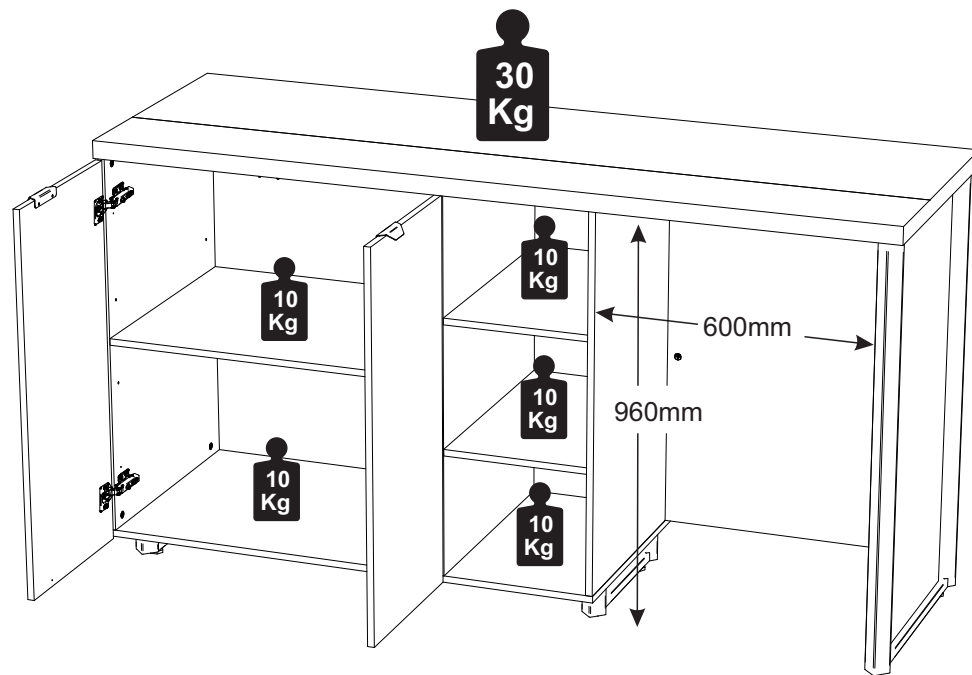

### Manutenção e Limpeza

Vidros: pano levemente umedecido com álcool, seguido de pano seco.  
Madeiras: pano levemente umedecido com água, seguido de pano seco.  
\*Nunca utilizar produtos químicos ou abrasivos.

### Maintenance and Cleaning

Glasses: cloth lightly moistened with alcohol, followed by dry cloth.  
Woods: cloth slightly moistened with water, followed by cloth se.  
\*Never use chemicals or abrasives.

### Mantenimiento y Limpieza

Vidrios: legeramente humedecido con alcohol, seguido de un paño seco.  
Madera: ligeramente humedecido con agua, seguido de un paño seco.  
\*No utilice nunca productos quimicos o abrasivos.

## INSTRUÇÕES DE MONTAGEM ASSEMBLY INSTRUCTIONS INSTRUCCIONES DE MONTAJE

BOS1760

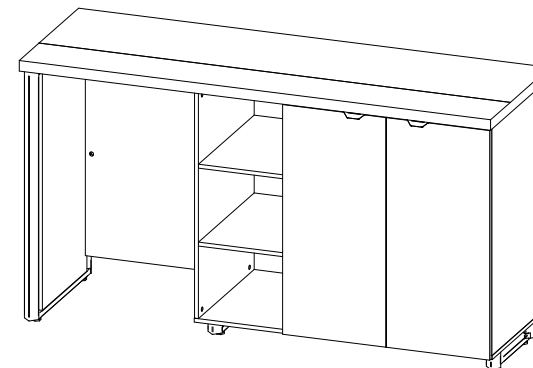
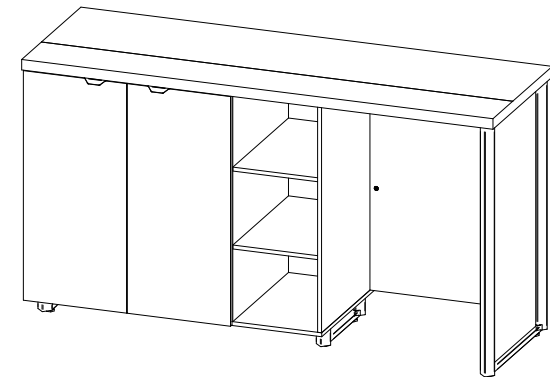

BOS1761

REF. # BOS1760/BOS1761

 **Gebbwork**

MOBILIÁRIO  
PARA ESCRITÓRIO

GEBB Work Ind. de Móveis Ltda.  
Rua Felix Roman, 190  
São Valentin

95709-170 - Bento Gonçalves - RS - Brasil  
Fone: (0XX54) 3454-1105 - (0XX54) 3453-1407  
Phone: (0XX54) 3454-1105 - (0XX54) 3453-1407

E-mail: pedidos@gebbwork.com.br

www.gebbwork.com.br

WhatsApp: +55 54 99177-8324

São necessários:  
Son necesarios:  
Are necessary:



\*Parafusadeira  
Atornillador  
Screwdriver



\*Martelo  
Martillo  
Hammer



Chave Cruzada  
Llave cruzada  
Cross wrench



\*\*Trena  
Cinta métrica  
Measuring tape



60min



2 Pessoas  
Persona  
Person

\*Facilita a montagem / Facilita un montaje / Facilitates mounting.  
\*\*Para identificar as peças / Para identificar las partes / To identify the parts.

# LISTA DE PEÇAS

PART LIST LISTA DE PIEZAS

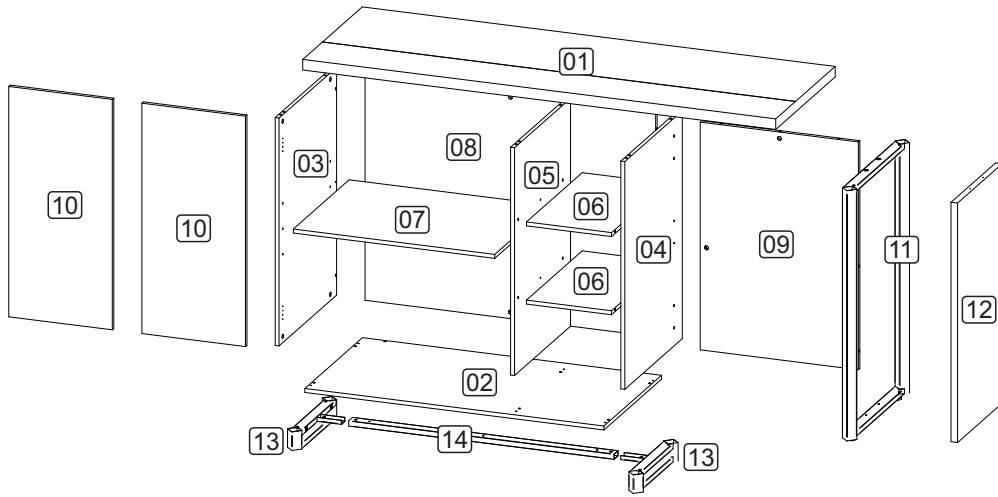

## LISTA DE PEÇAS

01 - TAMPO  
02 - BASE  
03 - LATERAL ESQUERDA  
04 - LATERAL DIREITA  
05 - DIVISÃO ESQUERDA  
06 - PRATELEIRA  
07 - PRATELEIRA MÓVEL  
08 - COSTA MAIOR  
09 - COSTA MENOR  
10 - PORTA  
11 - PÉ  
12 - APLIQUE PÉ  
13 - RODAPÉ METÁLICO  
14 - LONGARINA

## LISTA DE PIEZAS

01 - TOP  
02 - BASE  
03 - LEFT SIDE  
04 - RIGHT SIDE  
05 - LEFT DIVISION  
06 - SHELF  
07 - MOBILE SHELF  
08 - LARGER BACK  
09 - SMALLER BACK  
10 - DOOR  
11 - FOOT  
12 - FRAME  
13 - METAL SKIRTING BOARD  
14 - LONGITUDINAL

## PARTS IDENTIFICATION

01 - TABLERO DE MESA  
02 - BASE  
03 - LATERAL IZQUIERDO  
04 - LADO DERECHO  
05 - DIVISIÓN IZQUIERDA  
06 - ESTANTE  
07 - ESTANTE MÓVIL  
08 - COSTA MAYOR  
09 - COSTA MENOR  
10 - PUERTA  
11 - PIE  
12 - MARCO  
13 - RODAPIÉ METÁLICO  
14 - LARGUERO

# ACESSÓRIOS

ACCESSORIES ACCESORIOS

A8 - PARAF. 4,0x14 CP  
**32x**



A35 - TAMBOR MINIFIX  
**23x**



A32 - PARAF. MINIFIX  
**23x**

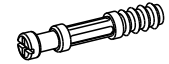

G1 - DOBRADIÇA CANECO 35 BAIXO  
**4x**

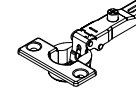

D1 - CAVILHA 8x30  
**34x**

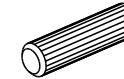

B1 - SUPORTE PRAT. METÁLICO  
**6x**

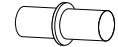

A13 - PARAF. 4,0x30 CP  
**3x**



A44 - PARAF. M6x16 CP  
**02x**



C11 - PUXADOR MET. BOSS  
**2x**

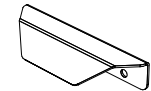

L2 - SAPATA PLAST. SEXT.  
**6x**



L5 - BUCHA PLÁSTICA P/SAPATA 5/16  
**6x**



A36 - BUCHA M6x13  
**2x**



A51 - PARAF. M6X35 CP  
**2x**



A6 - PARAF. 3,5x40 CC  
**4x**



# PRÉ-MONTAGEM / PREMONTAJE / PRE-ASSEMBLY

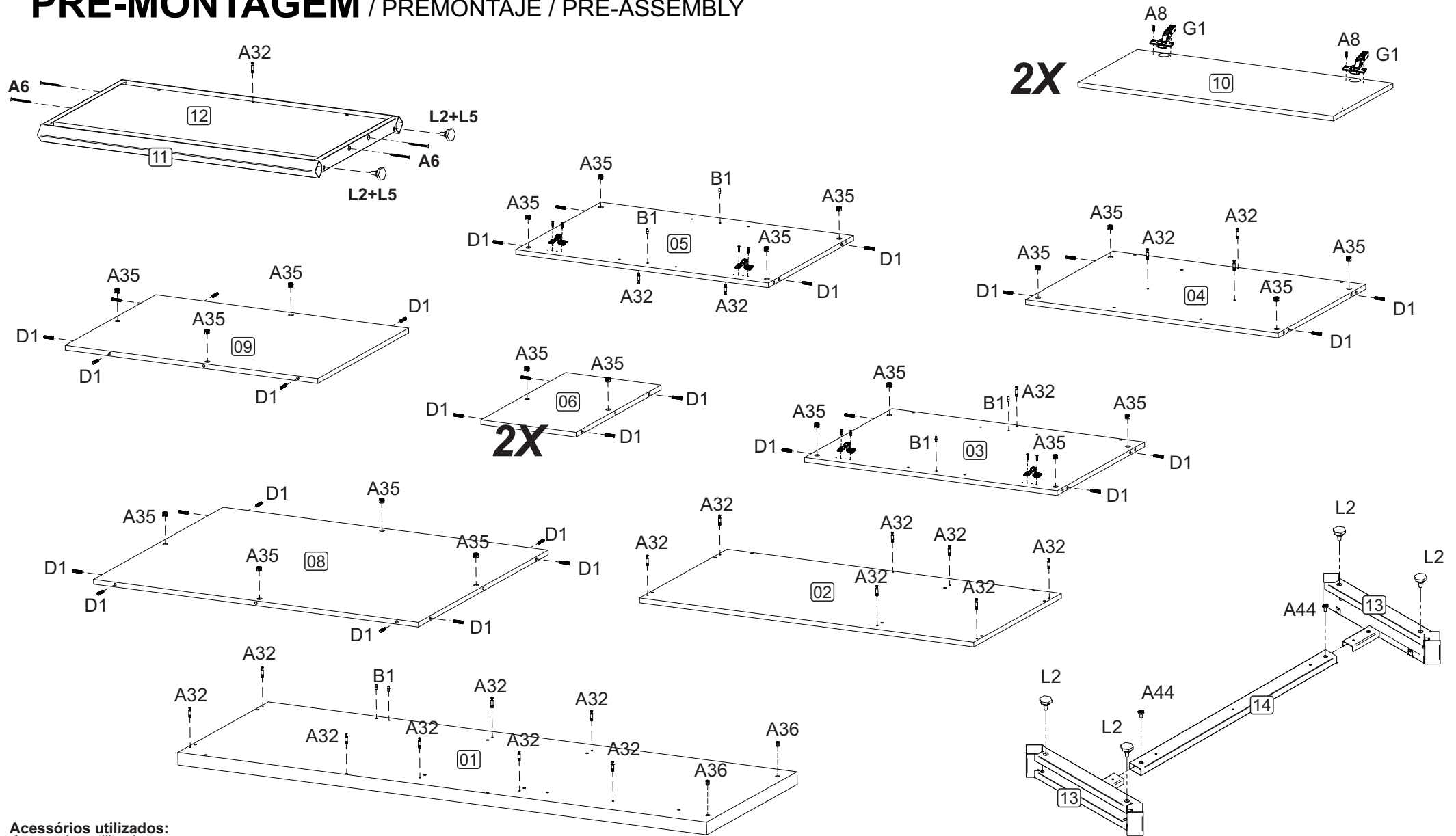

**Acessórios utilizados:**  
 Accesorios utilizados:  
 Accessories used:

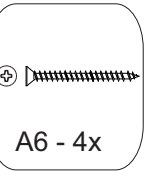
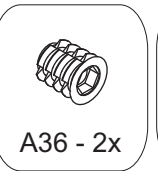
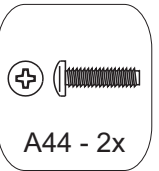
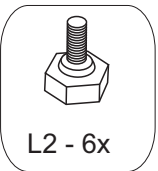
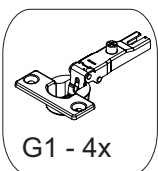
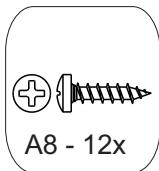
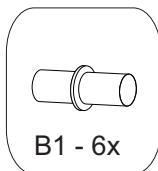
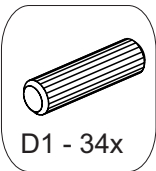

# 1 MONTAGEM VÃO FRIGOBAR LADO DIREITO

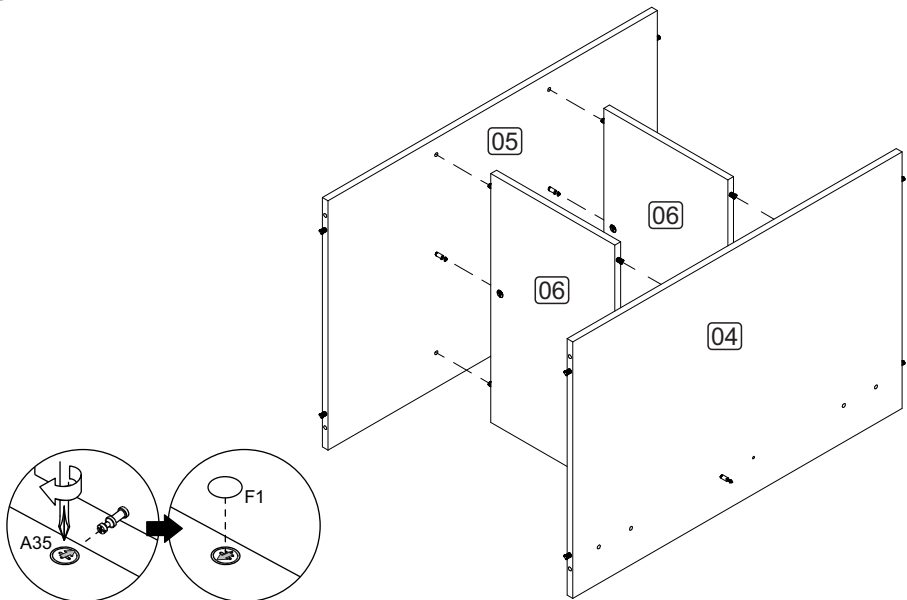

Depois de encaixar as peças coloque o tambor com a sua seta voltada para o parafuso. Para apertar Gire no sentido horário.  
 Después de colocar las piezas, coloque el tambor con su flecha hacia el tornillo. Para apretar, gire en sentido horario.  
 After fitting the parts, place the drum with its arrow facing the screw. To tighten, turn clockwise.

# MONTAGEM VÃO FRIGOBAR LADO ESQUERDO

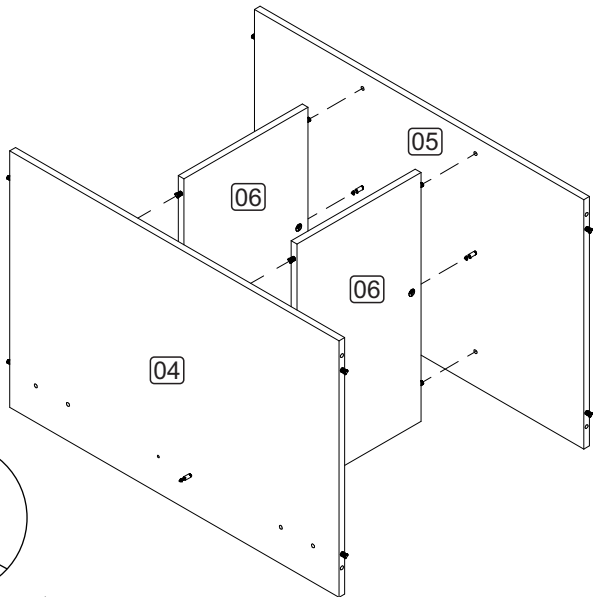

Depois de encaixar as peças coloque o tambor com a sua seta voltada para o parafuso. Para apertar Gire no sentido horário.  
 Después de colocar las piezas, coloque el tambor con su flecha hacia el tornillo. Para apretar, gire en sentido horario.  
 After fitting the parts, place the drum with its arrow facing the screw. To tighten, turn clockwise.

# 2 MONTAGEM VÃO FRIGOBAR LADO DIREITO

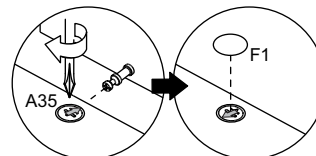

Depois de encaixar as peças coloque o tambor com a sua seta voltada para o parafuso. Para apertar Gire no sentido horário.  
 Después de colocar las piezas, coloque el tambor con su flecha hacia el tornillo. Para apretar, gire en sentido horario.  
 After fitting the parts, place the drum with its arrow facing the screw. To tighten, turn clockwise.

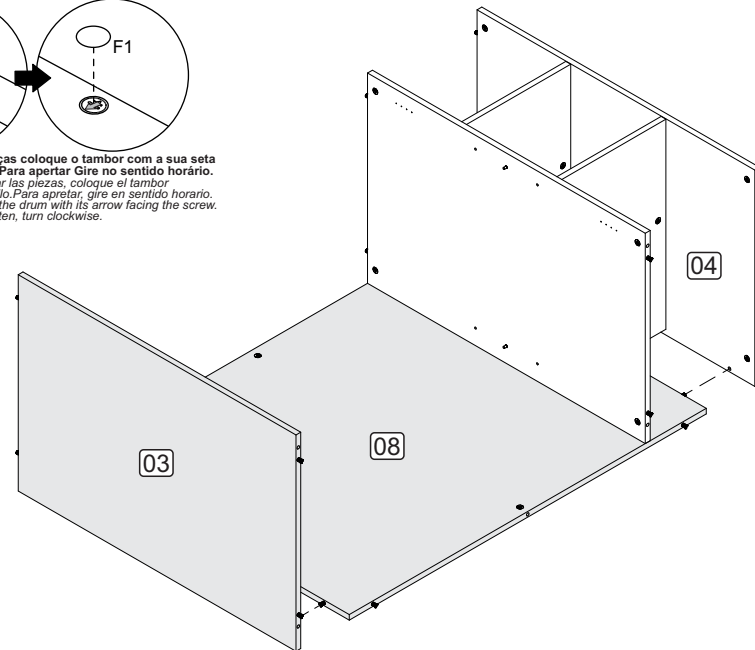

# MONTAGEM VÃO FRIGOBAR LADO ESQUERDO

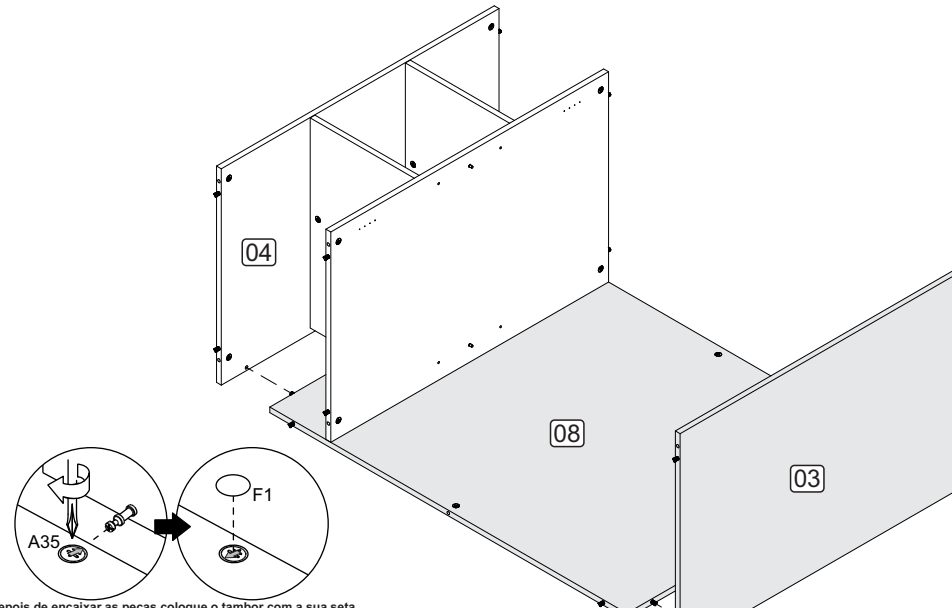

Depois de encaixar as peças coloque o tambor com a sua seta voltada para o parafuso. Para apertar Gire no sentido horário.  
 Después de colocar las piezas, coloque el tambor con su flecha hacia el tornillo. Para apretar, gire en sentido horario.  
 After fitting the parts, place the drum with its arrow facing the screw. To tighten, turn clockwise.

### 3 MONTAGEM VÃO FRIGOBAR LADO DIREITO

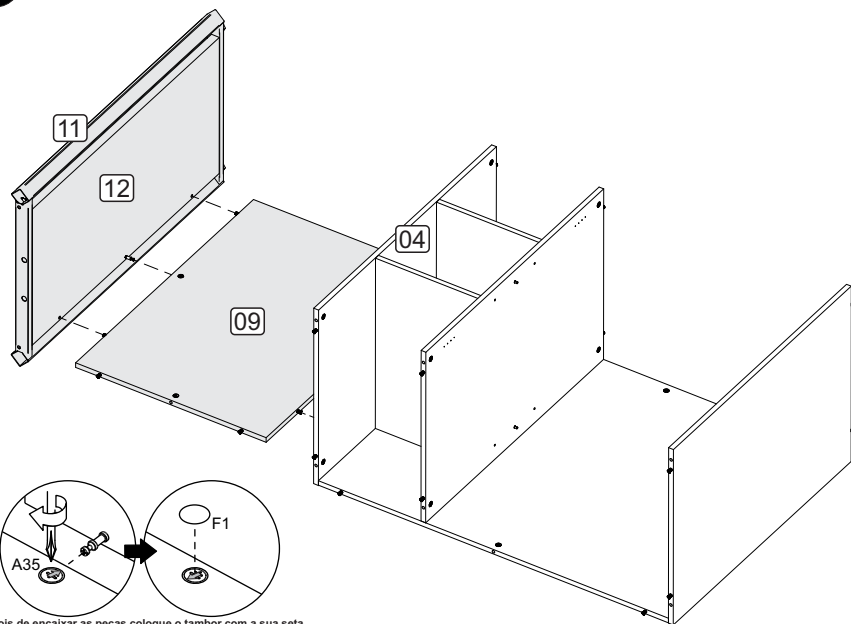

Depois de encaixar as peças coloque o tambor com a sua seta voltada para o parafuso. Para apertar Gire no sentido horário.  
 Después de colocar las piezas, coloque el tambor con su flecha hacia el tornillo. Para apretar, gire en sentido horario.  
 After fitting the parts, place the drum with its arrow facing the screw. To tighten, turn clockwise.

### MONTAGEM VÃO FRIGOBAR LADO ESQUERDO

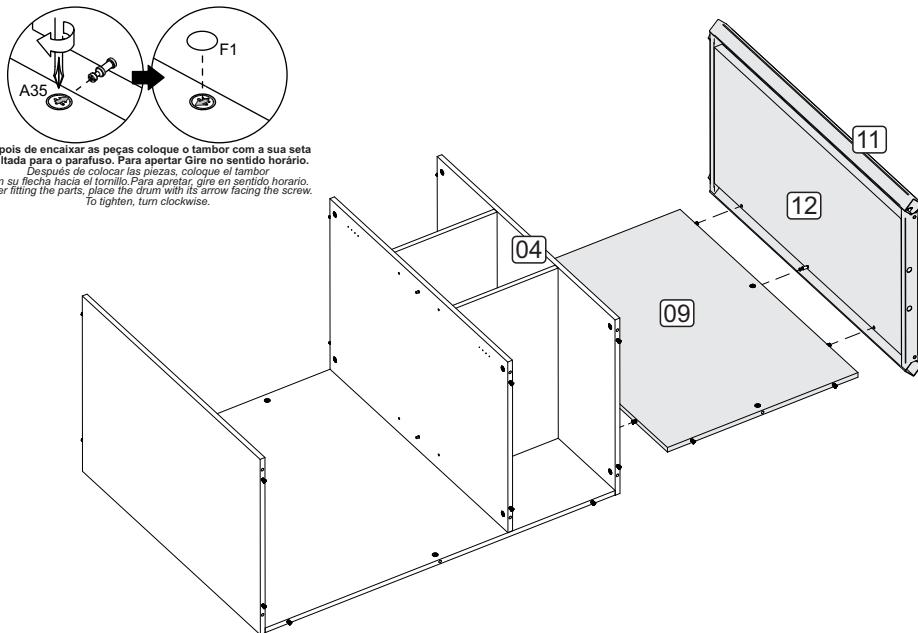

Depois de encaixar as peças coloque o tambor com a sua seta voltada para o parafuso. Para apertar Gire no sentido horário.  
 Después de colocar las piezas, coloque el tambor con su flecha hacia el tornillo. Para apretar, gire en sentido horario.  
 After fitting the parts, place the drum with its arrow facing the screw. To tighten, turn clockwise.

### 4 MONTAGEM VÃO FRIGOBAR LADO DIREITO

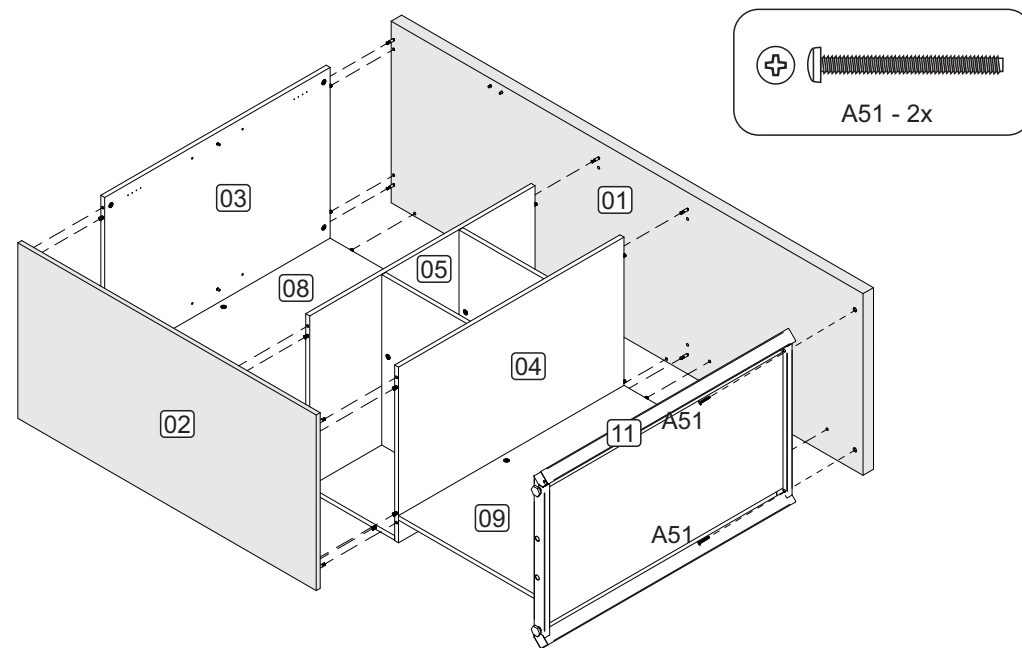

### MONTAGEM VÃO FRIGOBAR LADO ESQUERDO

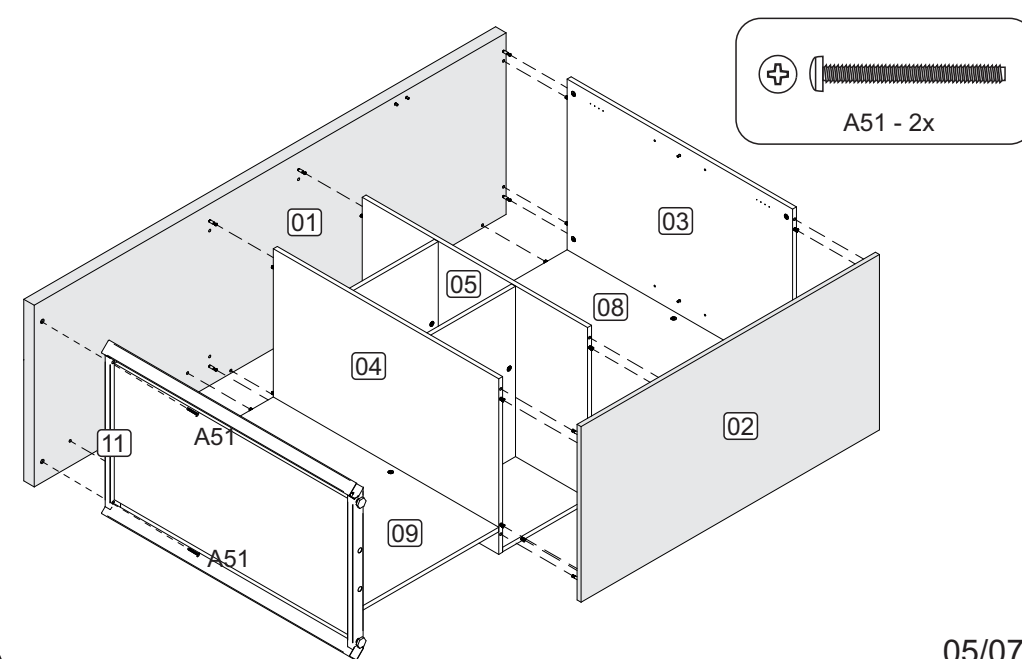

**5 MONTAGEM VÃO FRIGOBAR LADO DIREITO**

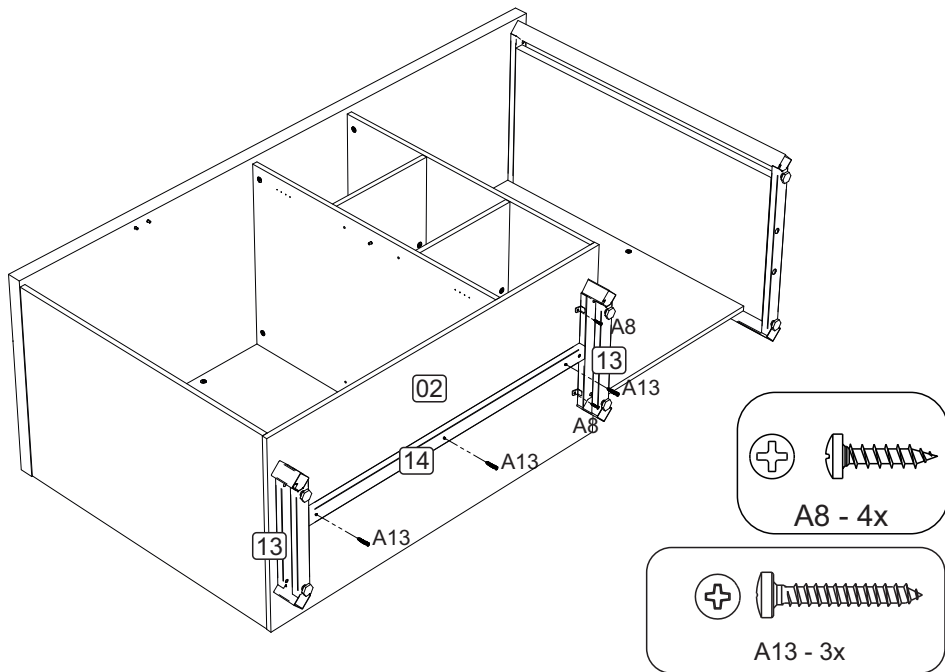

**MONTAGEM VÃO FRIGOBAR LADO ESQUERDO**

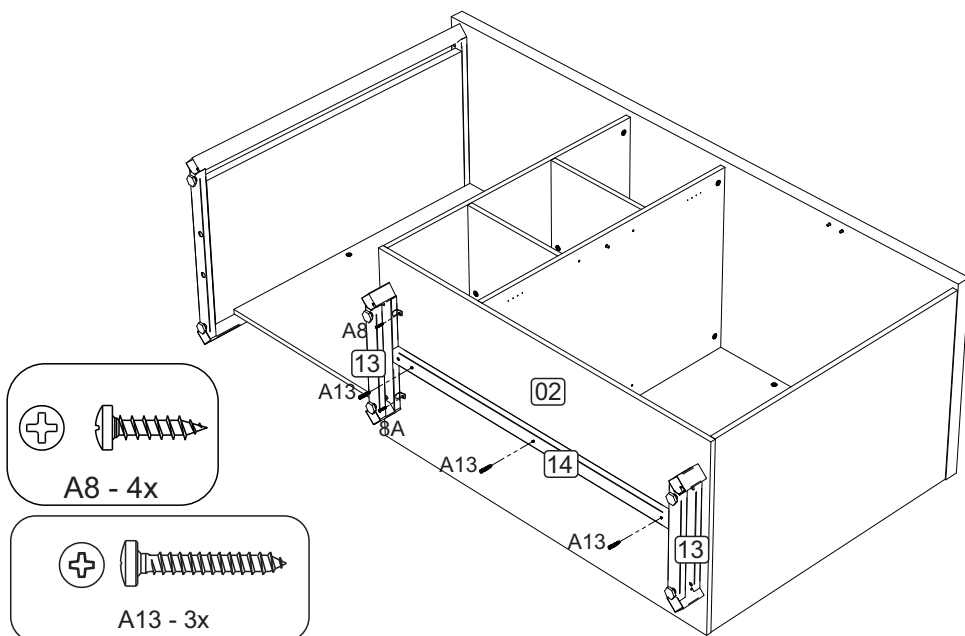

**6 MONTAGEM VÃO FRIGOBAR LADO DIREITO**

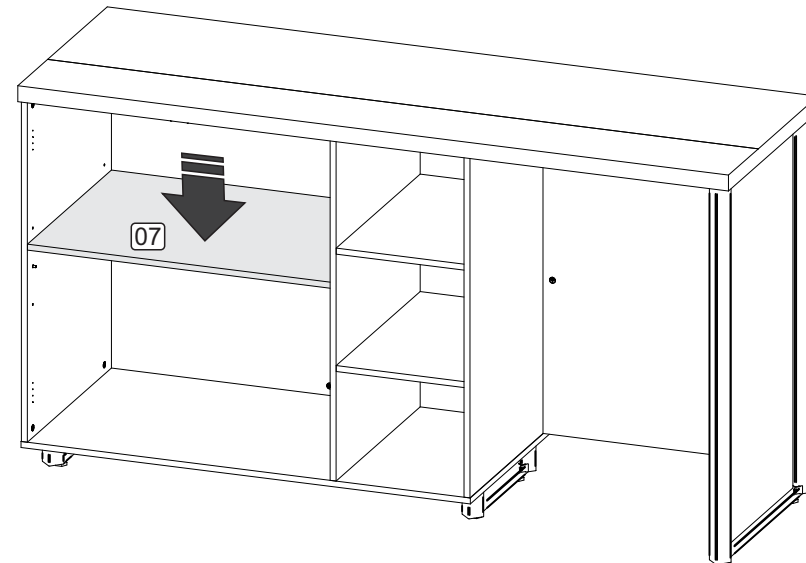

**MONTAGEM VÃO FRIGOBAR LADO ESQUERDO**

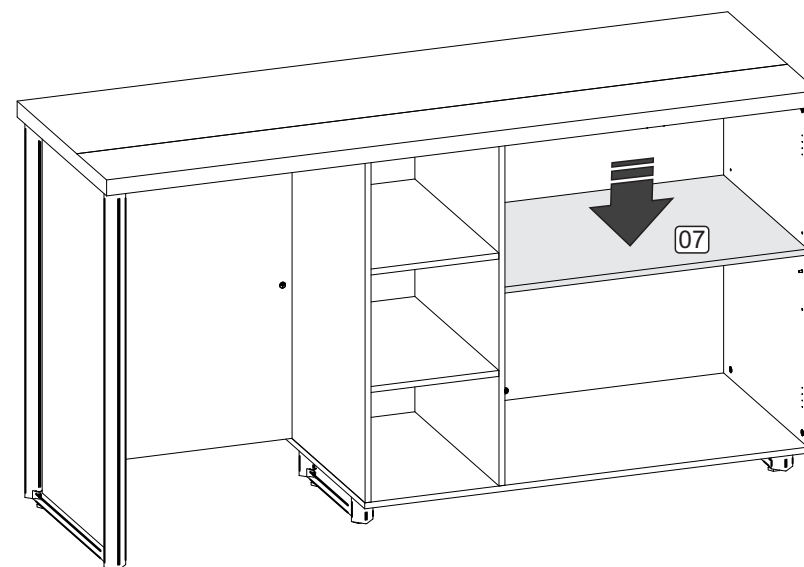

## MONTAGEM VÃO FRIGOBAR LADO DIREITO

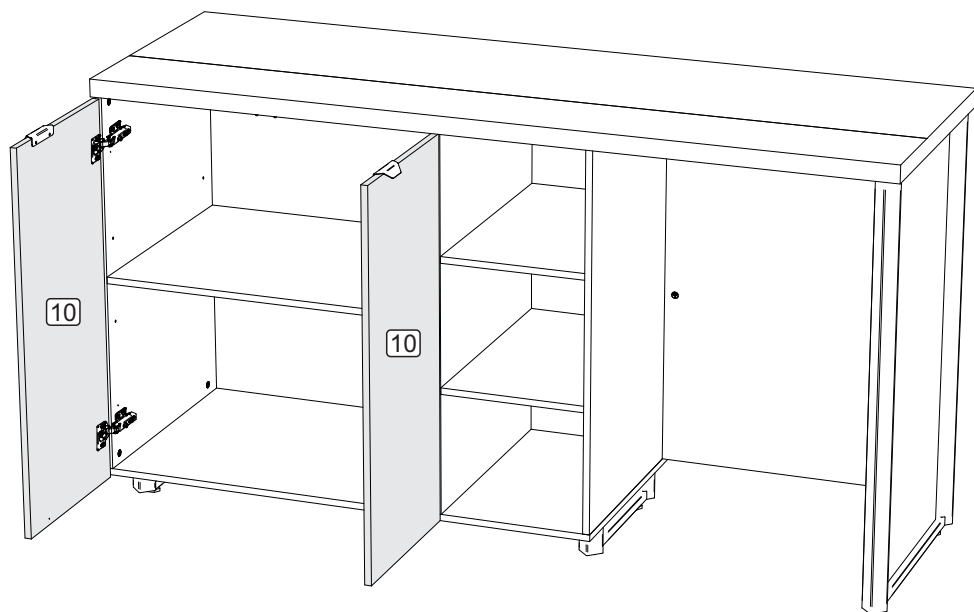

## MONTAGEM VÃO FRIGOBAR LADO ESQUERDO

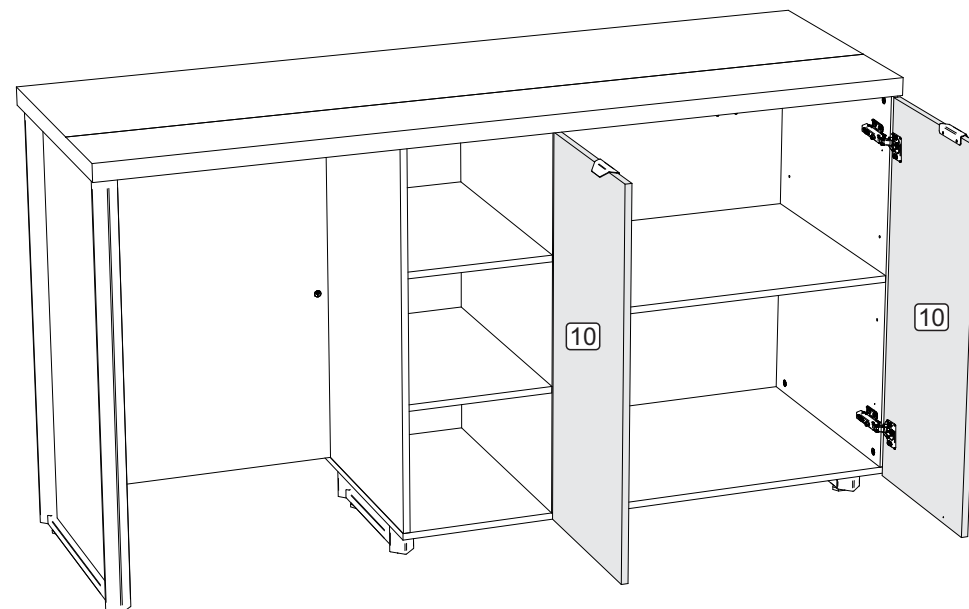

### AJUSTE DAS PORTAS

*Ajuste de puerta*

*Door adjustment*

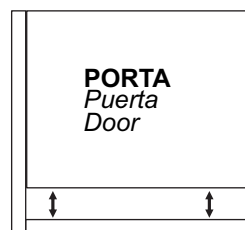

**AJUSTE DE ALTURA**  
*Ajuste de altura*  
*Height adjustment*

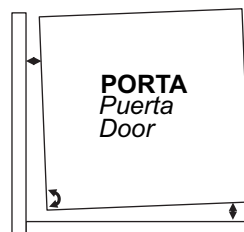
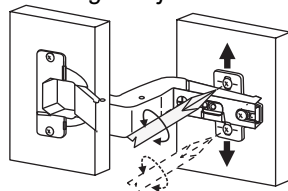

**AJUSTE INTERNO**  
*Ajuste interno*  
*Internal adjustment*

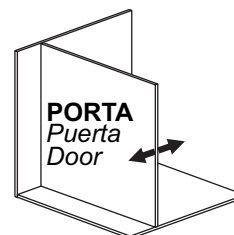
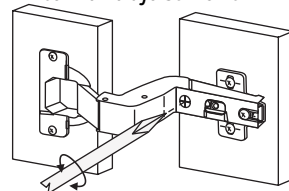

**AJUSTE DE PROFUNDIDADE**  
*Ajuste de profundidad*  
*Depth adjustment*

