

## Capacidade de Carga - Load Capacity - Capacidad de carga

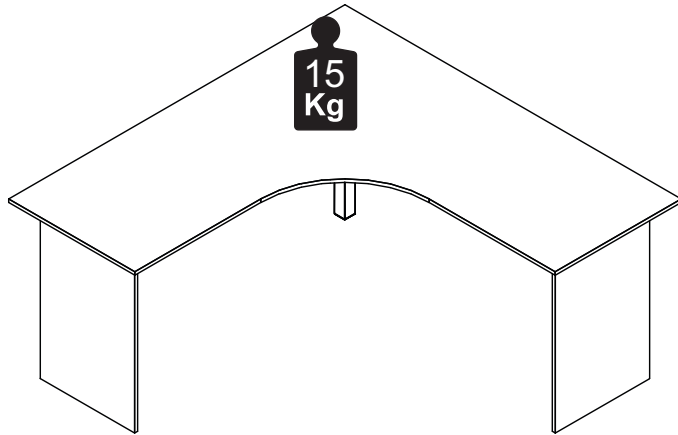

### Manutenção e Limpeza

Vidros: pano levemente umedecido com álcool, seguido de pano seco.  
Madeiras: pano levemente umedecido com água, seguido de pano seco.  
\*Nunca utilizar produtos químicos ou abrasivos.

### Maintenance and Cleaning

Glasses: cloth lightly moistened with alcohol, followed by dry cloth.  
Woods: cloth slightly moistened with water, followed by cloth seco.  
\*Never use chemicals or abrasives.

### Mantenimiento y Limpieza

Vidrios: legeramente humedecido con alcohol, seguido de un paño seco.  
Madera: ligeramente humedecido con agua, seguido de un paño seco.  
\*No utilice nunca productos quimicos o abrasivos.

## INSTRUÇÕES DE MONTAGEM ASSEMBLY INSTRUCTIONS INSTRUCCIONES DE MONTAJE

### MESA ANGULAR ANGLE TABLE TABLA DE ÁNGULOS

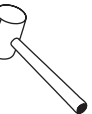
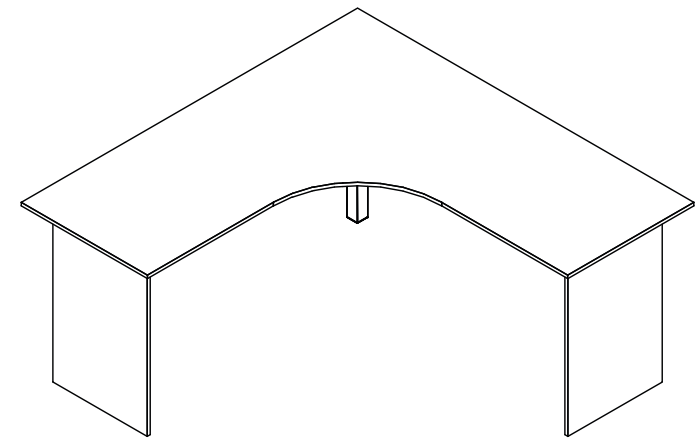

20mim

REF. #0346-0347-0348



MOBILIÁRIO  
PARA ESCRITÓRIO

GEBB Work Ind. de Móveis Ltda.  
Rua Felix Roman, 190  
São Valentin

95709-170 - Bento Gonçalves - RS - Brasil  
Fone: (0XX54) 3454-1105 - (0XX54) 3453-1407  
Phone: (0XX54) 3454-1105 - (0XX54) 3453-1407  
E-mail: [pedidos@gebbwork.com.br](mailto:pedidos@gebbwork.com.br)  
[www.gebbwork.com.br](http://www.gebbwork.com.br)  
WhatsApp: +55 54 99177-8324

## LISTA DE PEÇAS

- 01 - Pé Metálico Esquerdo
- 02 - Pé Metálico Direito
- 03 - Tampo
- 04 - Painel Frontal
- 05 - Pé

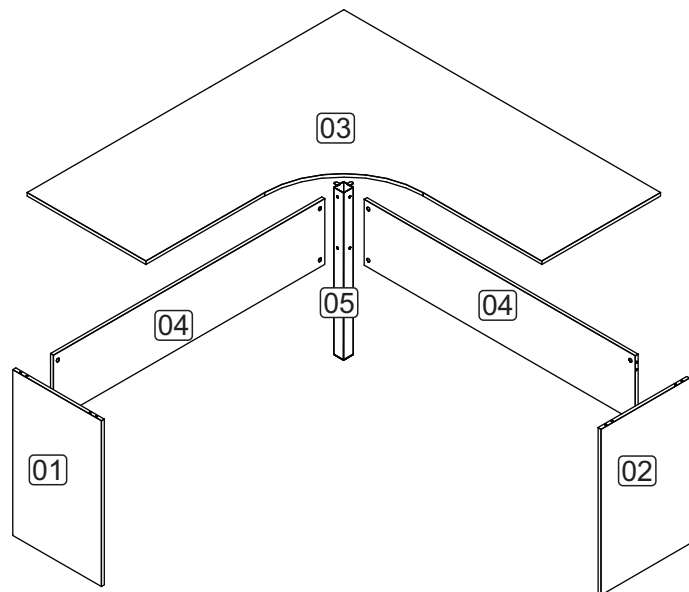

## LISTA DE PIEZAS

- 01 - Pie Izquierdo Metalico
- 02 - Pie Derecho Metalico
- 03 - Tapa
- 04 - Panel Frontal
- 05 - Pie

## PARTS IDENTIFICATION

- 01 - Left Foot Metallic
- 02 - Right Foot Metallic
- 03 - Top
- 04 - Front Panel
- 05 - Foot

4

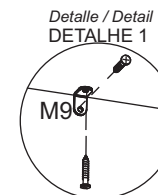
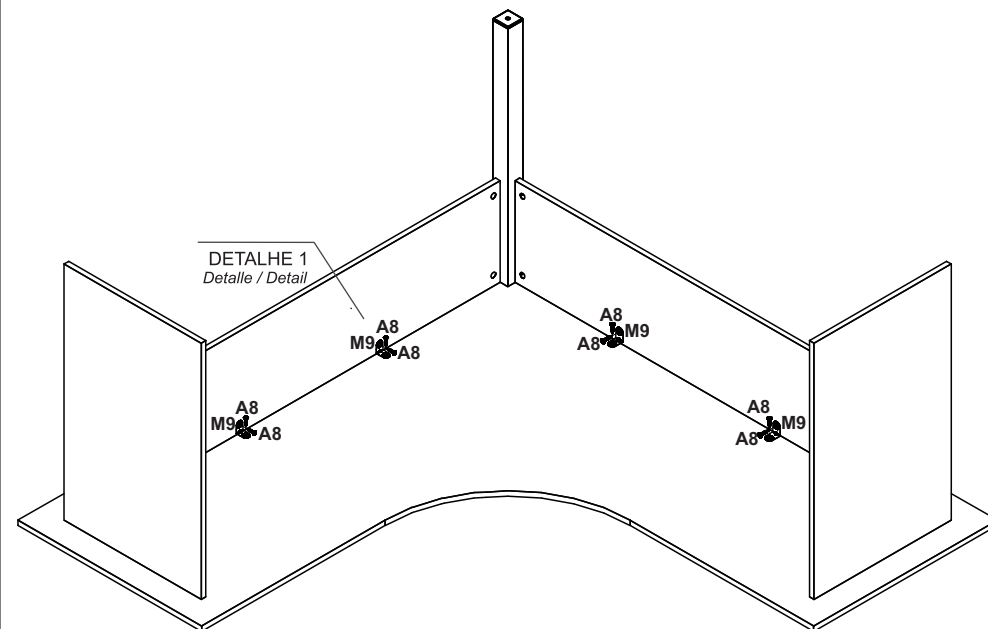

Posicione a cantoneira encostada na quina das peças.  
Coloque la ángulo contra la esquina de las piezas.  
Position the corner against the corner of the pieces.



M9 - 4x

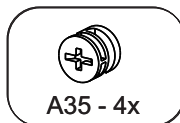
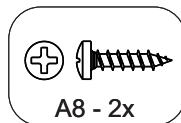
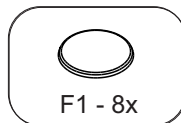
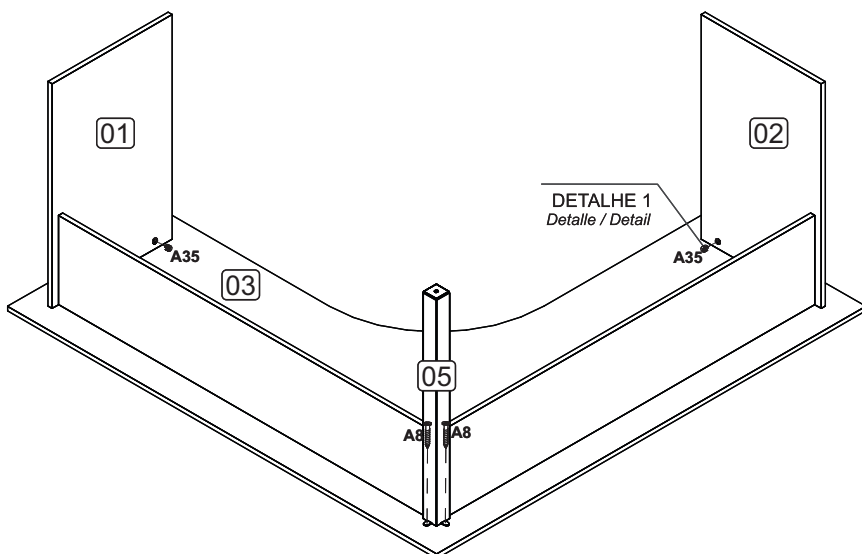

A8 - 8x

**3**

## ACESSÓRIOS ACCESSORIES ACCESORIOS

A8 - PARAF. 4,0x14 CP  
**10x**



A32 - PARAF. MINIFIX  
**8x**

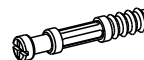

D1 - CAVILHA 8x30  
**8x**

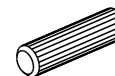

L2 - SAPATA PLAST.  
SEXT. **1x**



A35 - TAMBOR MINIFIX  
**12x**



L1 - SAPATA PLÁSTICA  
15x15 **4x**



M11 - PREGO 10x10  
**4x**



M9 - CANTONEIRA L  
2 FUROS ZAMAK **2x**



A29 - PARAF. MINIFIX  
M6x33m **4x**

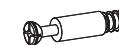

F1 - TAPA FURO Ø18  
**8x**



P11 - PONTEIRA 50X50  
ROSCA 5/16 PRETO **1x**



A35 - TAMBOR  
MINIFIX **12x**



# 1 PRÉ-MONTAGEM

Preasamblea  
Pre-assembly

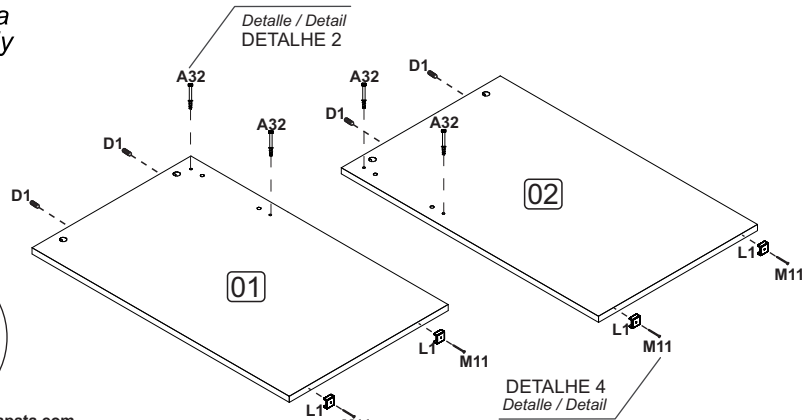

Detalle / Detail  
DETALHE 4

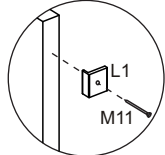

Com um martelo pregue a sapata com a aba para o lado de fora.  
Con un martillo, clava el zapato con la solapa hacia afuera.  
With a hammer, nail the shoe with the flap to the outside.

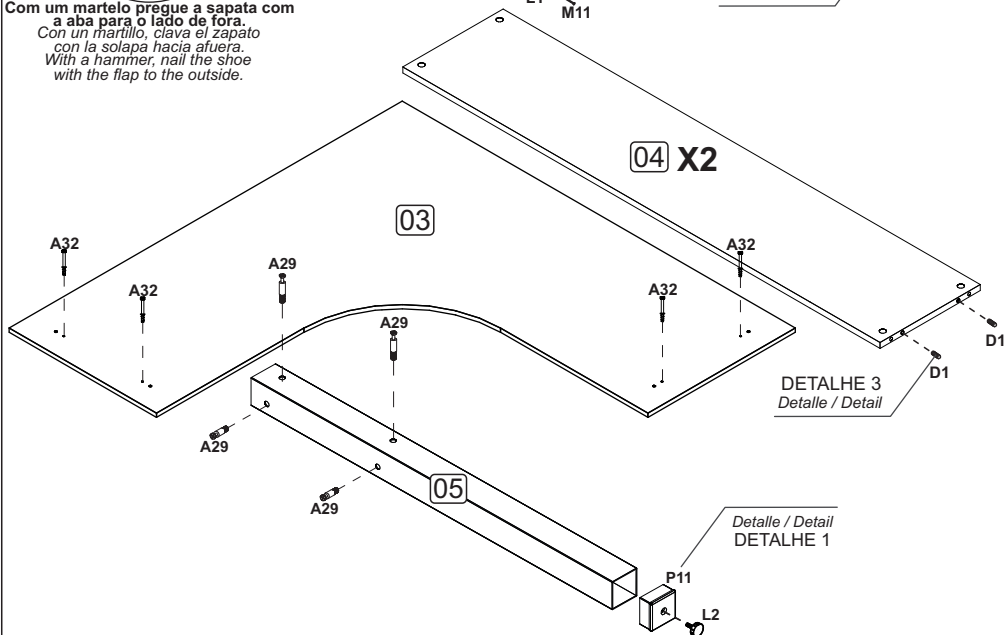

DETALHE 3  
Detalle / Detail

Detalle / Detail  
DETALHE 1

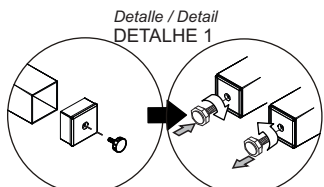

Insira a ponteira com um martelo e force a sapata.  
Inserte el portabrocas con un martillo y atornille la zapata.  
Insert the chuck with a hammer and screw the shoe.

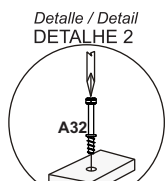

Parafuse com uma chave de fenda cruzada.  
Atornille con un destornillador cruzado.



Pressione até o fundo do furo.  
Presione hasta el fondo del agujero.  
Si es necesario, utilice un mazo de goma.  
Press to the bottom of the hole.  
If necessary use a rubber mallet.

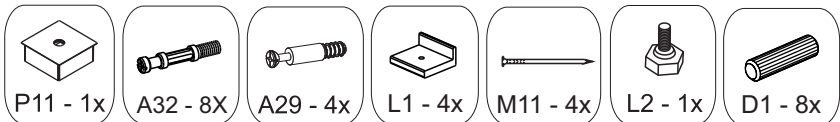

# 2 MONTAGEM

Armado  
Assembly

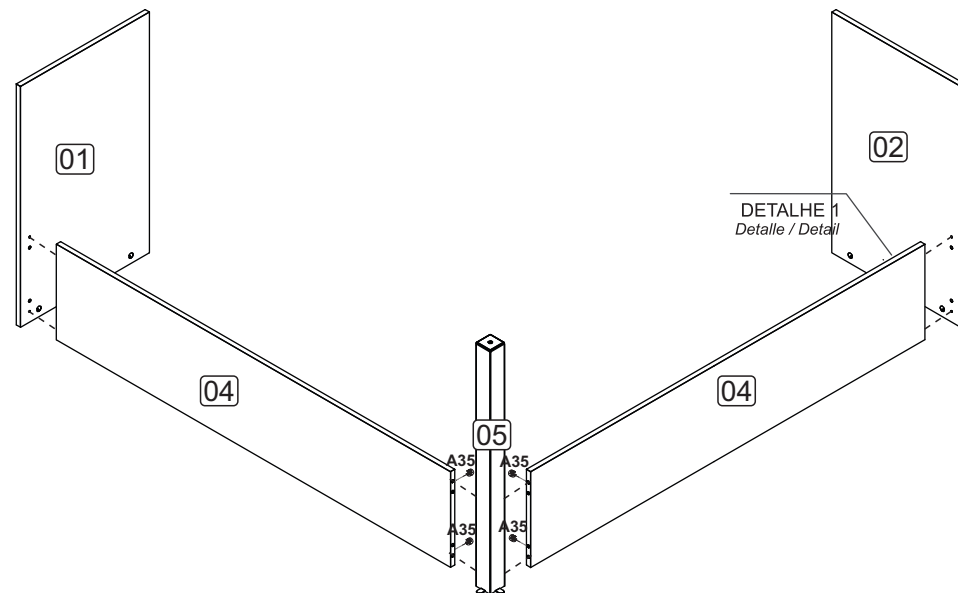

DETALHE 1  
Detalle / Detail

Detalle / Detail  
DETALHE 1

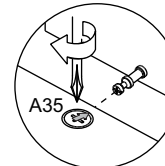

Depois de encaixar as peças coloque o tambor com a sua seta voltada para o parafuso. Para apertar Gire no sentido horário.  
Después de colocar las piezas, coloque el tambor con su flecha hacia el tornillo. Para apretar, gire en sentido horario.  
After fitting the parts, place the drum with its arrow facing the screw.  
To tighten, turn clockwise.

