

Capacidade de Carga - Load Capacity - Capacidad de carga

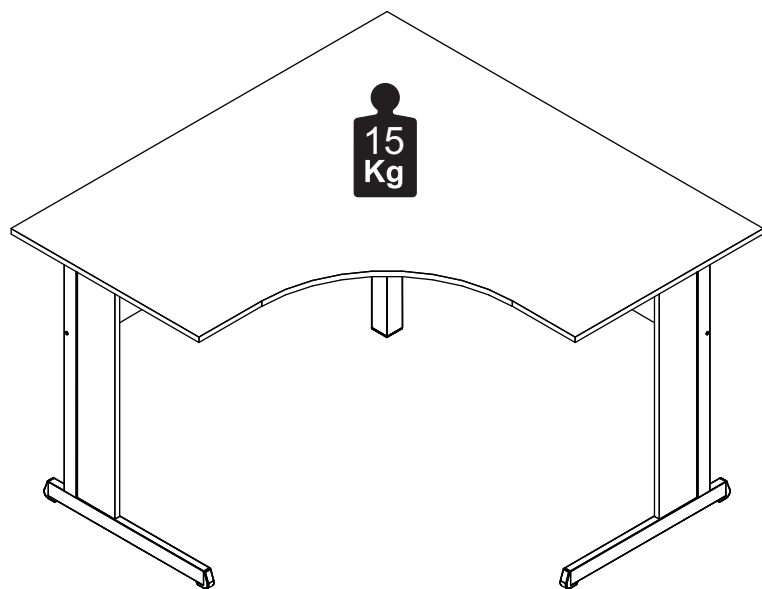

Manutenção e Limpeza

Vidros: pano levemente umedecido com álcool, seguido de pano seco.
Madeiras: pano levemente umedecido com água, seguido de pano seco.
*Nunca utilizar produtos químicos ou abrasivos.

Maintenance and Cleaning

Glasses: cloth lightly moistened with alcohol, followed by dry cloth.
Woods: cloth slightly moistened with water, followed by cloth seo.
*Never use chemicals or abrasives.

Mantenimiento y Limpieza

Vidrios: legeramente humedecido con alcohol, seguido de un paño seco.
Madera: ligeramente humedecido con agua, seguido de un paño seco.
*No utilice nunca productos quimicos o abrasivos.

INSTRUÇÕES DE MONTAGEM ASSEMBLY INSTRUCTIONS INSTRUCCIONES DE MONTAJE

MESA ANGULAR ANGLE TABLE TABLA DE ÁNGULOS

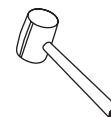
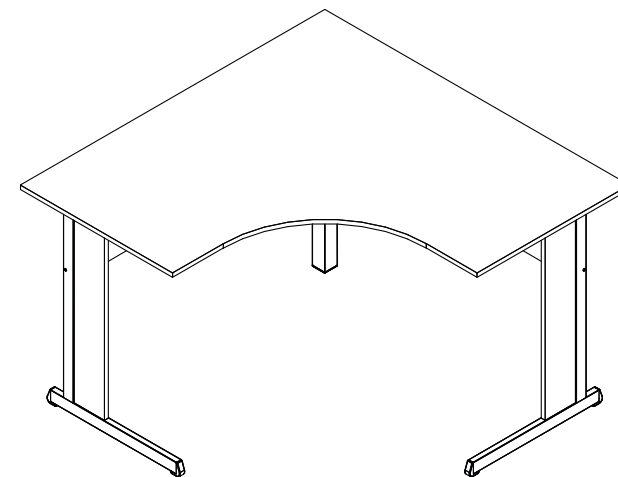

REF. #0352-0353-0354



MOBILIÁRIO
PARA ESCRITÓRIO

GEBB Work Ind. de Móveis Ltda.
Rua Felix Roman, 190
São Valentin

95709-170 - Bento Gonçalves - RS - Brasil
Fone: (0XX54) 3454-1105 - (0XX54) 3453-1407
Phone: (0XX54) 3454-1105 - (0XX54) 3453-1407
E-mail: pedidos@gebbwork.com.br
www.gebbwork.com.br
WhatsApp: +55 54 99177-8324

LISTA DE PEÇAS

- 01 - Pé Metálico Esquerdo
- 02 - Pé Metálico Direito
- 03 - Tampo
- 04 - Painel Frontal
- 05 - Pé
- 06 - Aplique

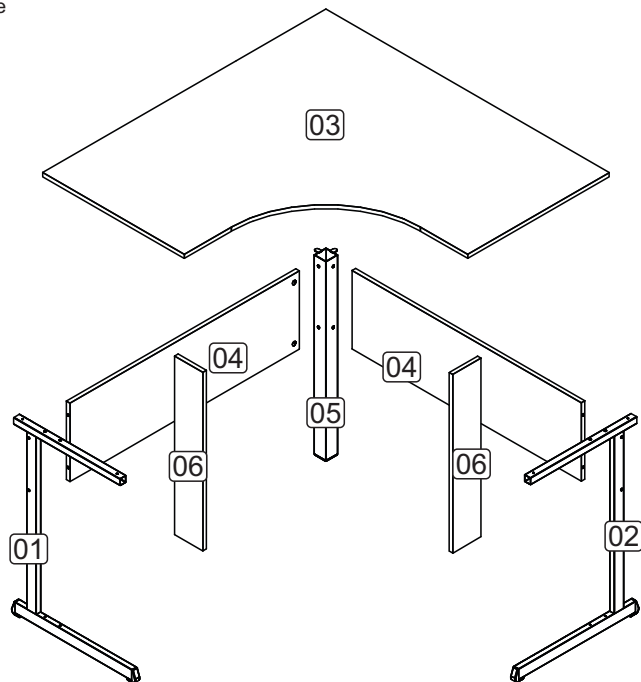

LISTA DE PIEZAS

- 01 - Pie Izquierdo Metalico
- 02 - Pie Derecho Metalico
- 03 - Tapa
- 04 - Panel Frontal
- 05 - Pie
- 06 - Detalle

PARTS IDENTIFICATION

- 01 - Left Foot Metallic
- 02 - Right Foot Metallic
- 03 - Top
- 04 - Front Panel
- 05 - Foot
- 06 - Detail

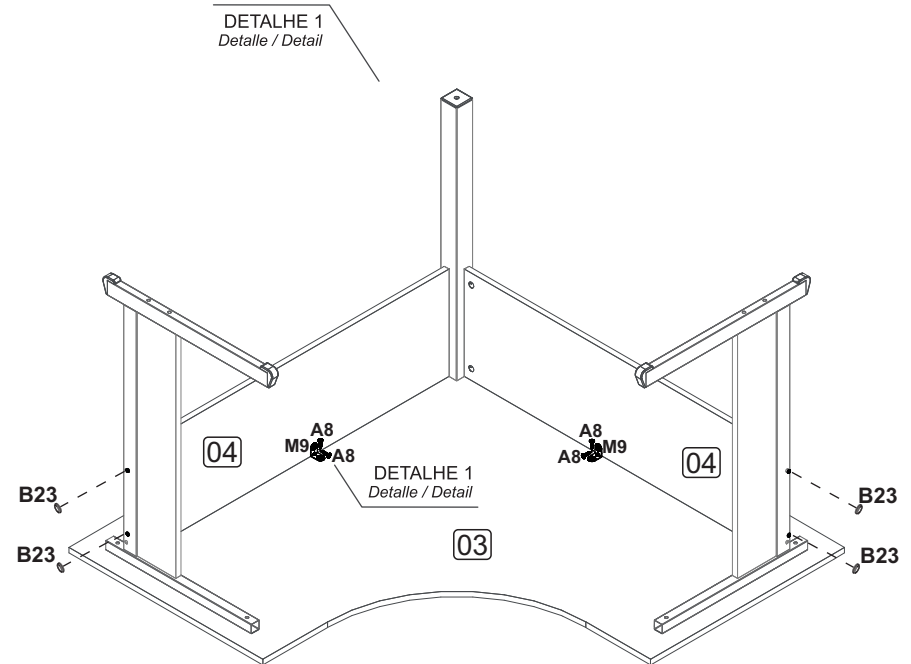

Detalle / Detail
DETALHE 1

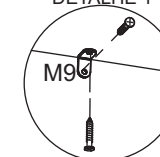

Posicione a cantoneira encostada na quina das peças.
Coloque la angulo contra la esquina de las piezas.
Position the corner against the corner of the pieces.



M9 - 2x

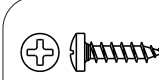

A8 - 8x

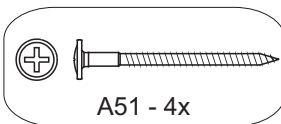
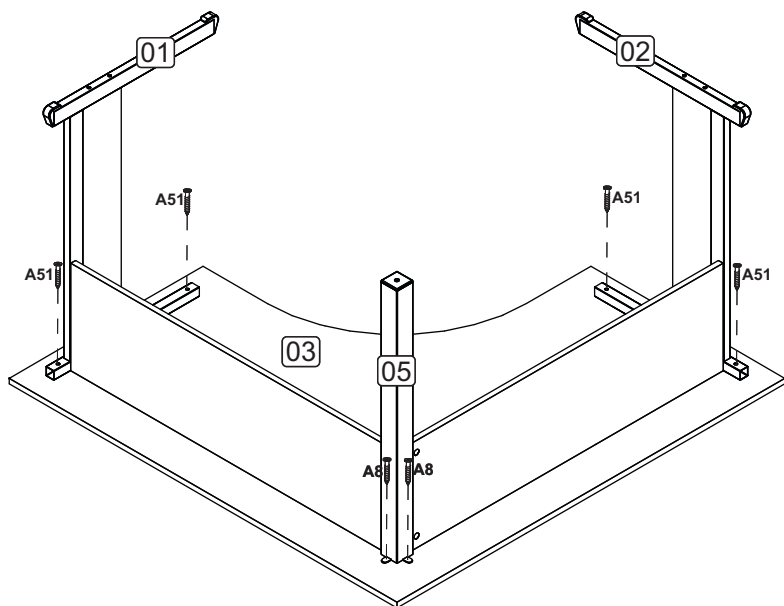

B23 - 4x

3

ACESSÓRIOS ACCESSORIES ACCESORIOS

A8 - PARAF. 4,0x14 CP
10x



A35 - TAMBOR MINIFIX
4x



A29 - PARAF. MINIFIX
M6x33m 4x

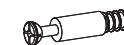

A15 - PARAF. 4,0x40 CP
8x



A49 - PARAF. 7,0x40
04x



A51 - PARAF. 4,0x35 CF
4x



B23 - TAMPA P/PARAF.
ENCAIXE 4x



P15 - PONTEIRA INTERNA
PLAST. 25 X 25 MM 4x

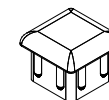

P11 - PONTEIRA 50X50
ROSCA 5/16 PRETO 1x



L2 - SAPATA PLAST.
SEXT. 1x



P16 - PONTEIRA 20X40
PLAST. ABAULADA C/C 4x



M9 - CANTONEIRA L
2 FUROS ZAMAK 2x



F1 - TAPA FURO \varnothing 18
4x



1 PRÉ-MONTAGEM

Preasamblea
Pre-assembly

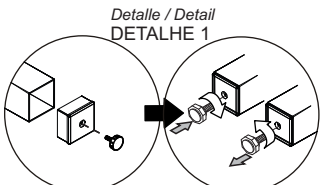
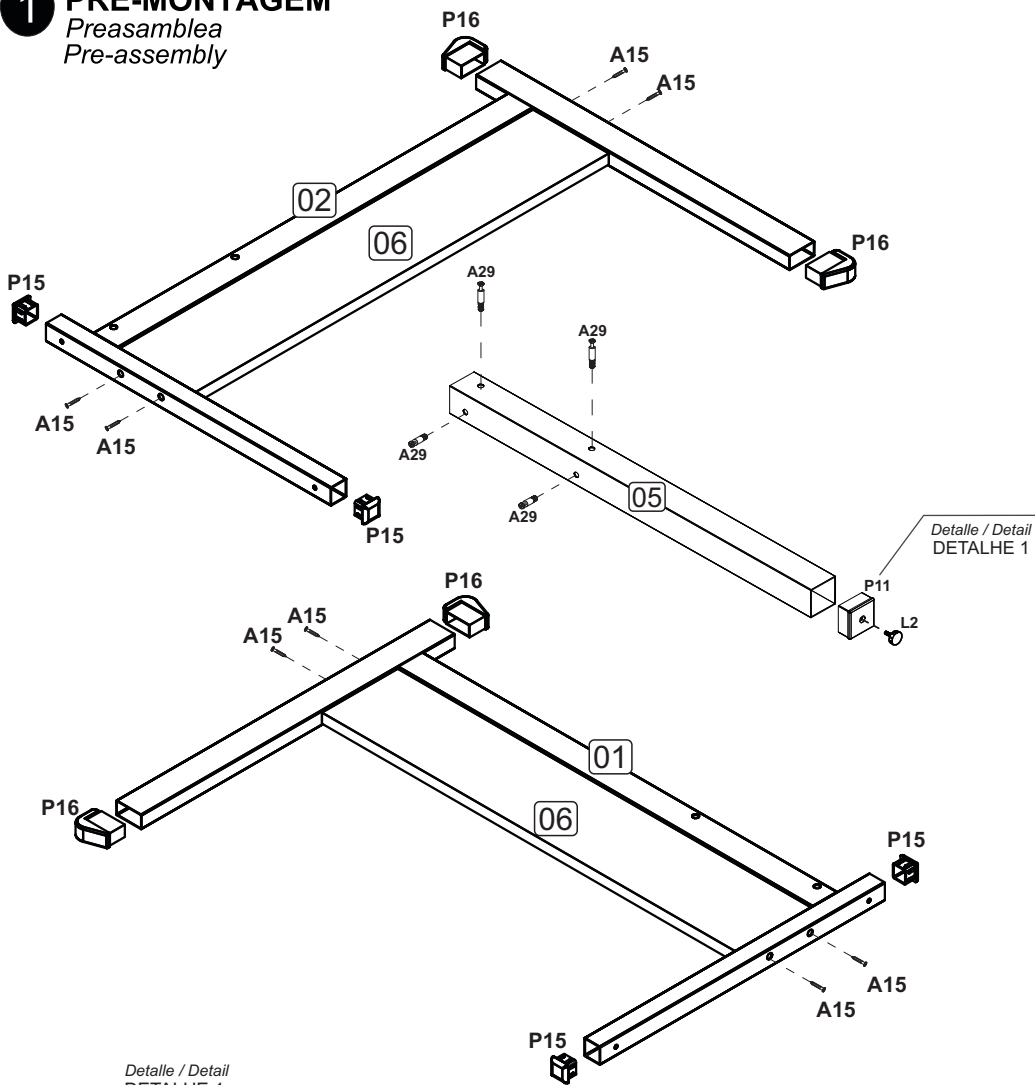

Insira a ponteira com um martelo e rosqueie a sapata.
Inserte el portabrocas con un martillo y atornille la zapata.
Insert the chuck with a hammer and screw the shoe.

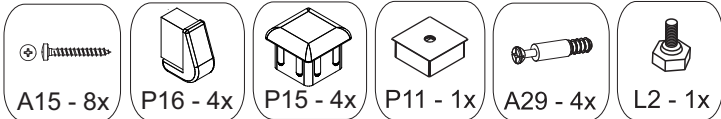

2 MONTAGEM

Armado
Assembly

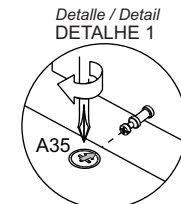
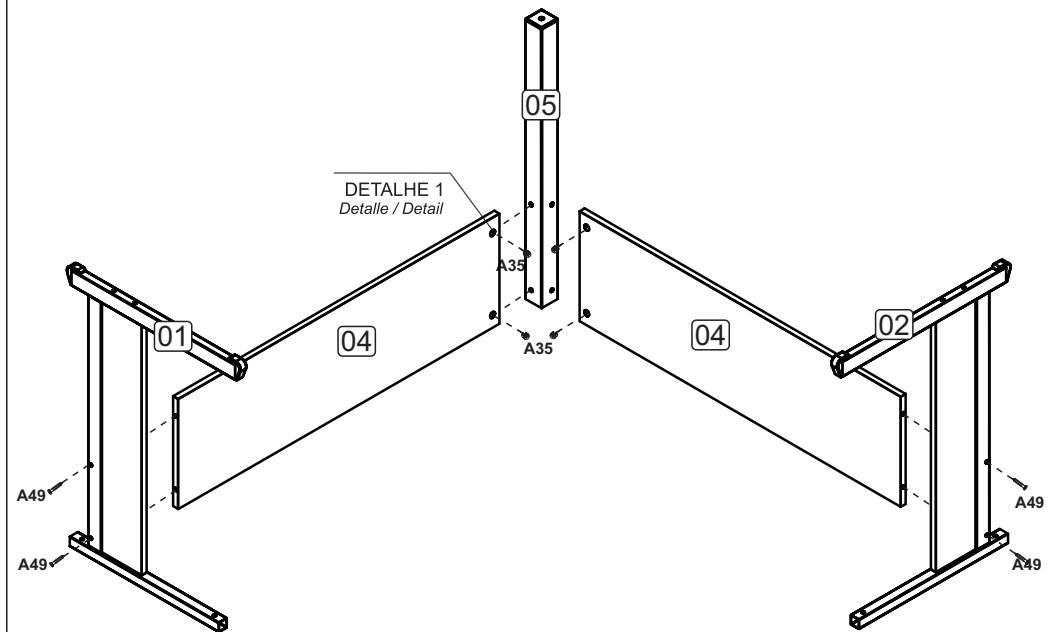

Depois de encaixar as peças coloque o tambor com a sua seta voltada para o parafuso. Para apertar Gire no sentido horário.
Después de colocar las piezas, coloque el tambor con su flecha hacia el tornillo. Para apretar, gire en sentido horario.
After fitting the parts, place the drum with its arrow facing the screw. To tighten, turn clockwise.

