

## Capacidade de Carga - Load Capacity - Capacidad de carga

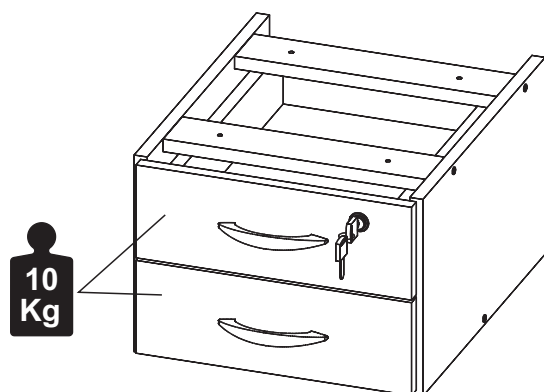

### Manutenção e Limpeza

Vidros: pano levemente umedecido com álcool, seguido de pano seco.  
Madeiras: pano levemente umedecido com água, seguido de pano seco.  
\*Nunca utilizar produtos químicos ou abrasivos.

### Maintenance and Cleaning

Glasses: cloth lightly moistened with alcohol, followed by dry cloth.  
Woods: cloth slightly moistened with water, followed by cloth seo.  
\*Never use chemicals or abrasives.

### Mantenimiento y Limpieza

Vidrios: legeramente humedecido con alcohol, seguido de un paño seco.  
Madera: ligeramente humedecido con agua, seguido de un paño seco.  
\*No utilice nunca productos químicos o abrasivos.

## Certificado de garantia

A garantia dos produtos fabricados pela Gebb Work Indústria de Móveis LTDA, abrange eventuais defeitos de fabricação, no prazo estabelecido pelo Código de Defesa do Consumidor, em seu artigo 26, II, o qual prevê a garantia legal de 90 (noventa) dias.

## INSTRUÇÕES DE MONTAGEM ASSEMBLY INSTRUCTIONS INSTRUCCIONES DE MONTAJE

### GAVETEIRO DRAWERS CAJONERO

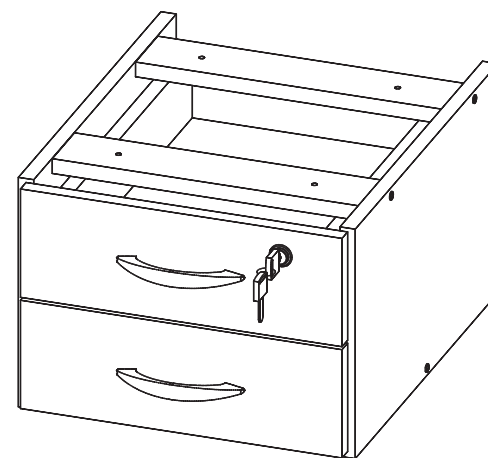

1 P.



25mim

REF. # 0310



MOBILIÁRIO  
PARA ESCRITÓRIO

GEBB Work Ind. de Móveis Ltda.  
Rua Felix Roman, 190  
São Valentin

95709-170 - Bento Gonçalves - RS - Brasil  
Fone: (0XX54) 3454-1105 - (0XX54) 3453-1407  
Phone: (0XX54) 3454-1105 - (0XX54) 3453-1407

E-mail: [pedidos@gebbwork.com.br](mailto:pedidos@gebbwork.com.br)  
[www.gebbwork.com.br](http://www.gebbwork.com.br)

WhatsApp: +55 54 99177-8324

## LISTA DE PEÇAS

- 01 - Lateral Esquerda
- 02 - Lateral Direita
- 11 - Frente Gaveta
- 12 - Frente Gaveta Tranca
- 13 - Lateral Esq. Gaveta
- 14 - Lateral Dir. Gaveta
- 15 - Costa Gaveta
- 16 - Fundo Gaveta
- 17 - Travessa Superior
- 18 - Travessa Inferior

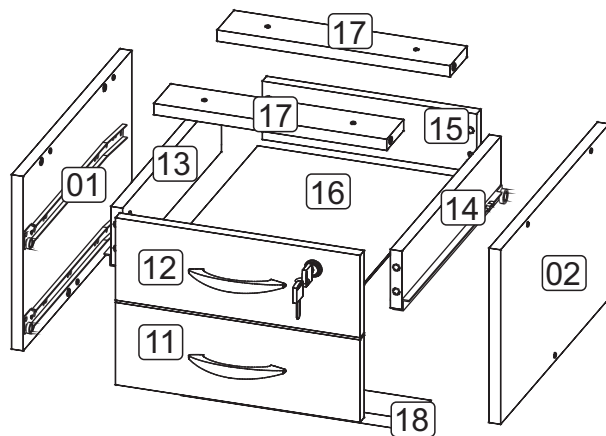

## LISTA DE PIEZAS

- 01 - Lateral Izquierda
- 02 - Lateral Derecha
- 11 - Frente Cajón
- 12 - Frente Cajón tranca
- 13 - Lateral Izq. Cajón
- 14 - Lateral Der. Cajón
- 15 - Revés Cajón
- 16 - Fondo Cajón
- 17 - Guión Superior
- 18 - Guión inferior

## PARTS IDENTIFICATION

- 01 - Left Side
- 02 - Right Side
- 11 - Drawer Front
- 12 - Front Drawer Locks
- 13 - Left Drawer Side
- 14 - Right Drawer Side
- 15 - Drawer Back
- 16 - Drawer Bottom
- 17 - Uppermost
- 18 - lower lane

6

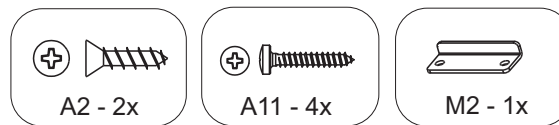
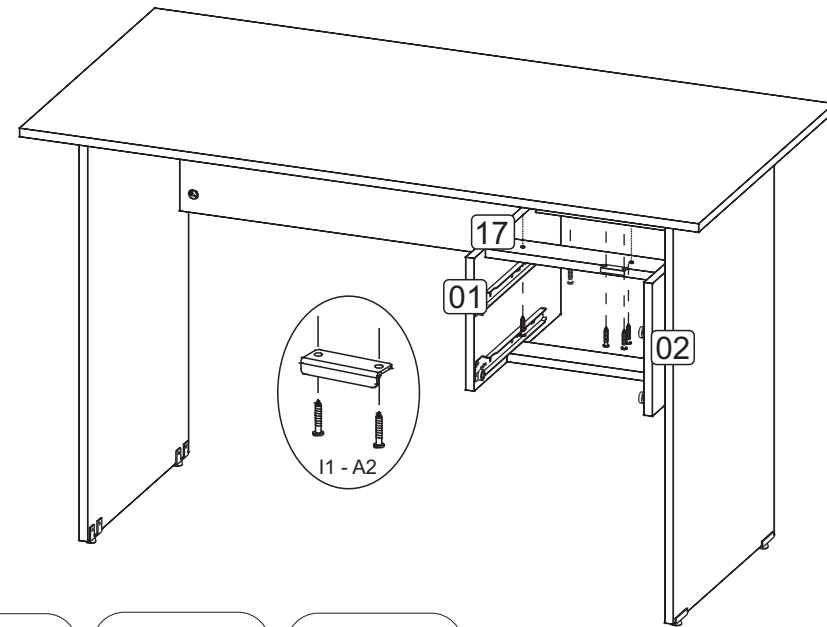

7

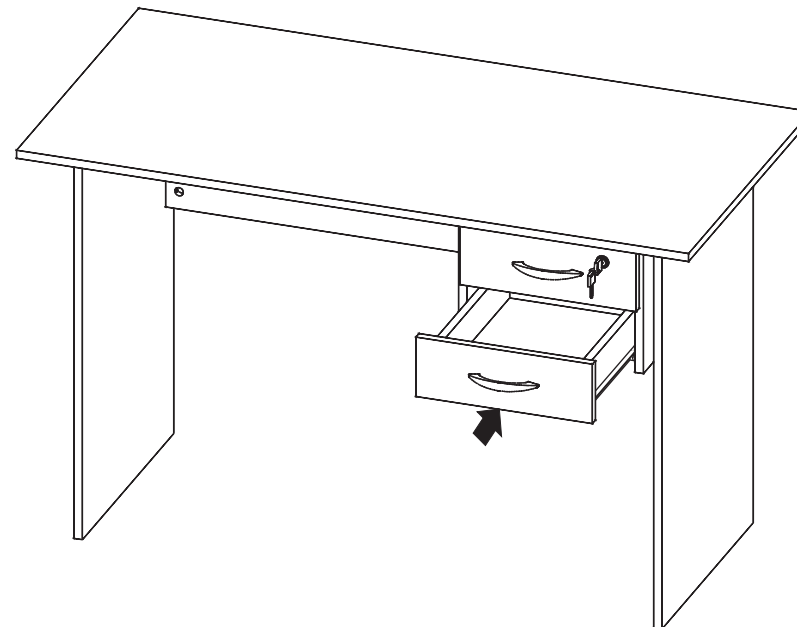

# 4 (2x)

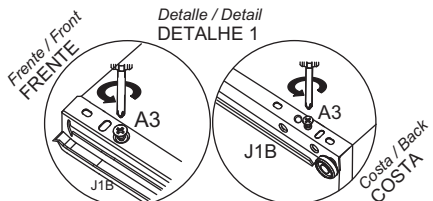
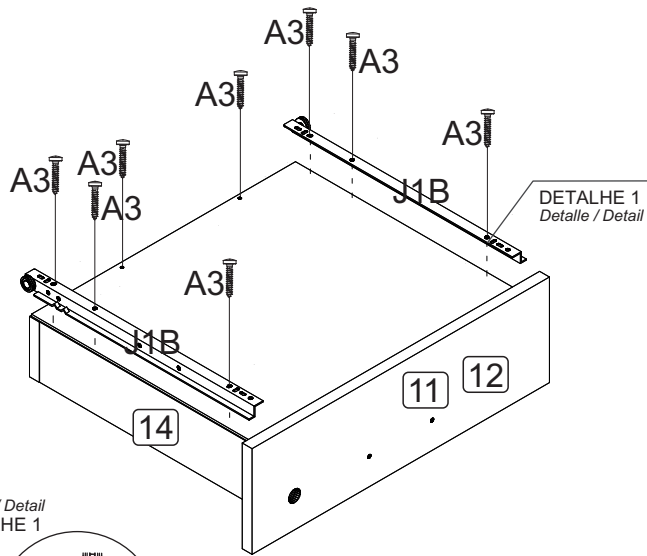

Identifique o esquerdo e o direito. Rolamento voltado para costa e parafusado por baixo da gaveta através do fundo e laterais.  
 Identifica la izquierda y la derecha. Rodamiento frente a la costa y atornillado debajo del cajón por el fondo y los lados.  
 Identify the left and the right. Bearing facing the coast and screwed under the drawer through the bottom and sides.

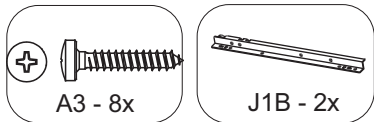

# 5 (2x)

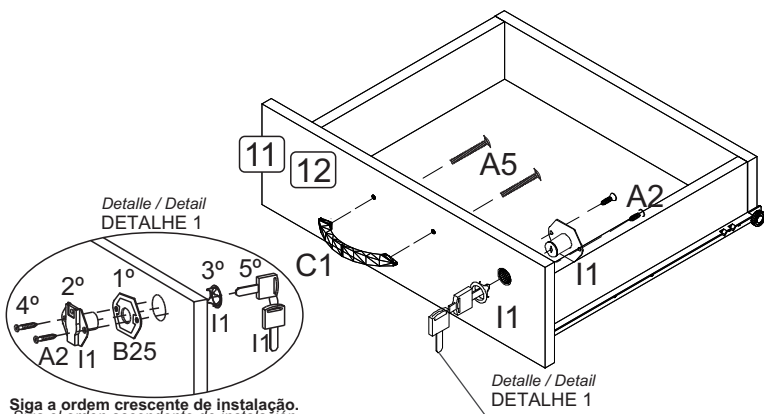

Siga a ordem crescente de instalação.  
 Siga el orden ascendente de instalación  
 Follow the ascending order of installation

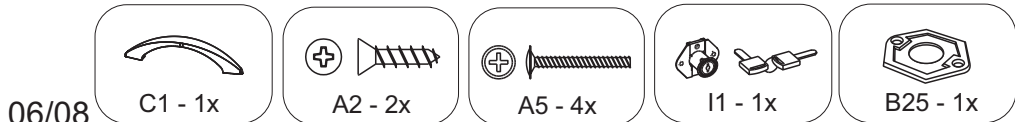

# ACESSÓRIOS ACCESSORIES ACCESORIOS

A2 - PARAF. 3,5x14 CC  
**12x**



A5 - PARAF. 3,5x25 CF  
**4x**



A6 - PARAF. 3,5x40 CC  
**10x**



A11 - PARAF. 4,0x25 CP  
**4x**



A32 - PARAF. MINIFIX  
**4x**

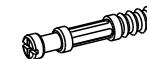

A3 - PARAF. 3,5x20 CP  
**16x**



C1 - PUXADOR  
**2x**



D1 - CAVILHA 8x30  
**14x**

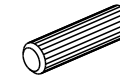

F1 - TAPA FURO ø18  
**4x**



I1 - FECHADURA P/GAV.  
**1x**



B25 - SEPARADOR PARA  
 FECHADURA **1x**



J1 - CORREDIÇA 350mm  
**2x**



M2 - CHAPA L 2 FUROS  
 OBL 42x17x0,9mm ZB **1x**



A35 - TAMBOR  
 MINIFIX **4x**



Medir os acessórios na régua abaixo.

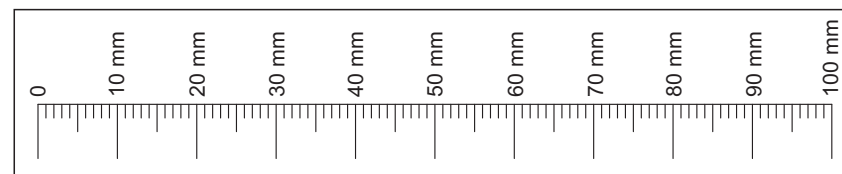

# 1 PRÉ-MONTAGEM

Preassembly  
Pre-assembly

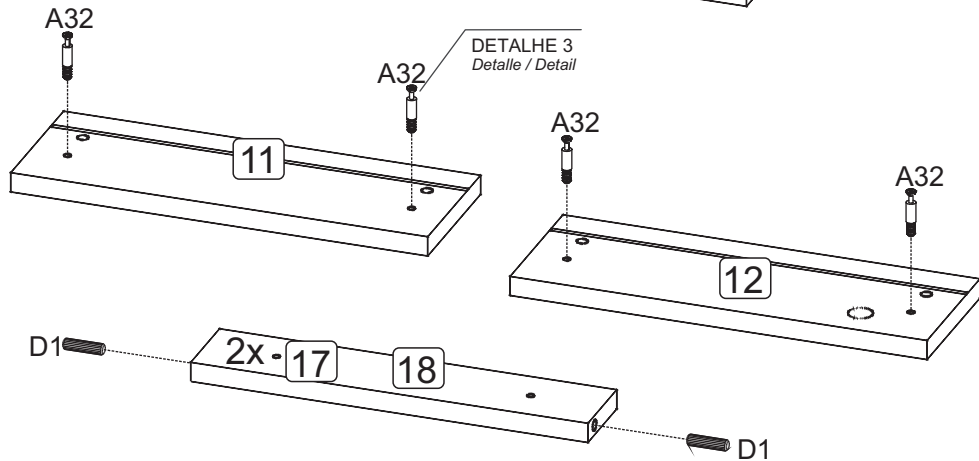
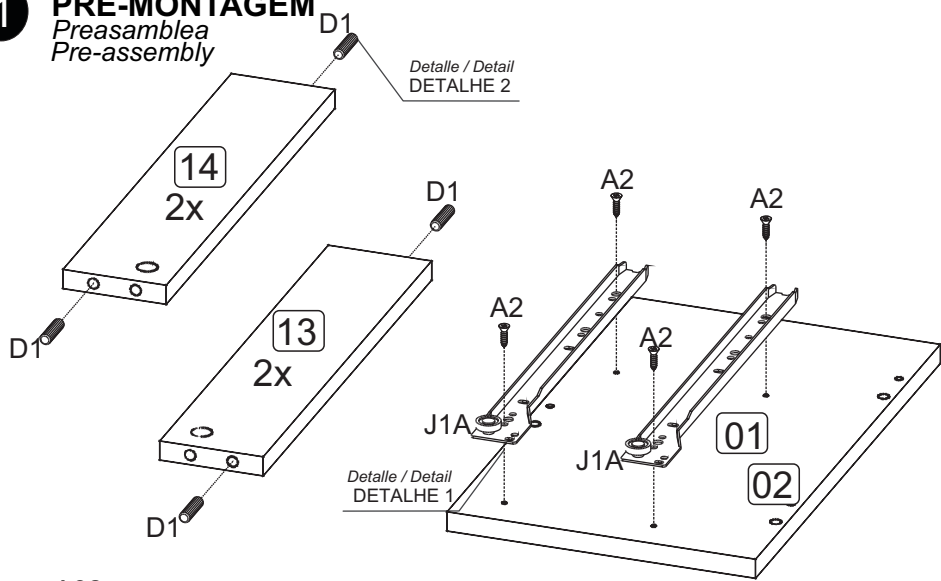

Detalle / Detail  
DETALHE 1

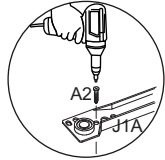

Detalle / Detail  
DETALHE 2

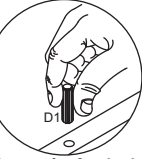

Detalle / Detail  
DETALHE 3

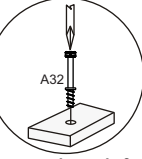

Pressione até o fundo do furo.  
Se necessário utilize um martelo de borracha.  
Presione hasta el fondo del agujero.  
Si es necesario, utilice un mazo de goma.

Parafuse com uma chave de fenda cruzada.  
Atornille con un destornillador cruzado.  
Screw with a crossed screwdriver.

Coloque sobre as marcações e parafuse no 'x'.  
Coloque sobre las marcas y atornille la 'x'.  
Place over the markings and screw in the 'x'.

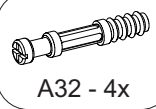

A32 - 4x

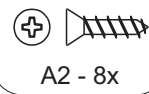

A2 - 8x

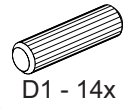

D1 - 14x

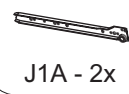

J1A - 2x

# 2 MONTAGEM

Armado  
Assembly

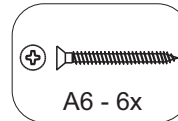
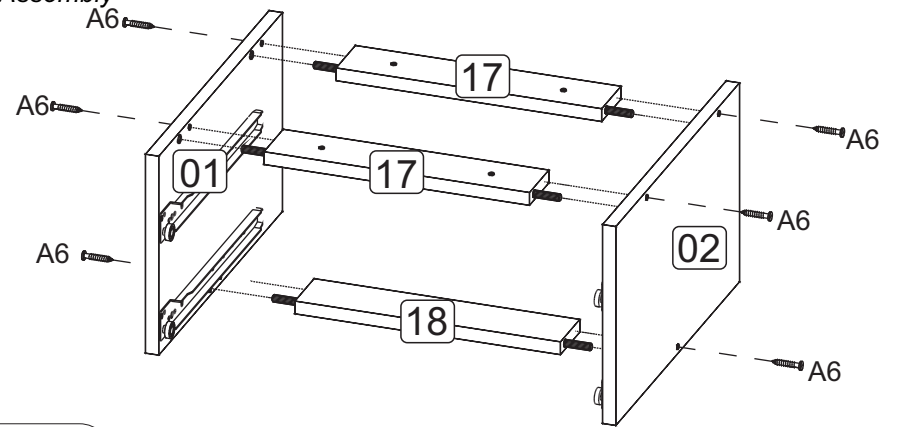

A6 - 6x

# 3 (2x)

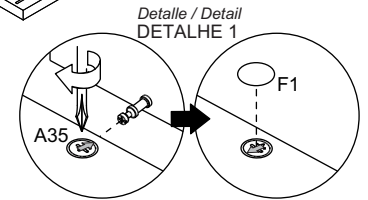
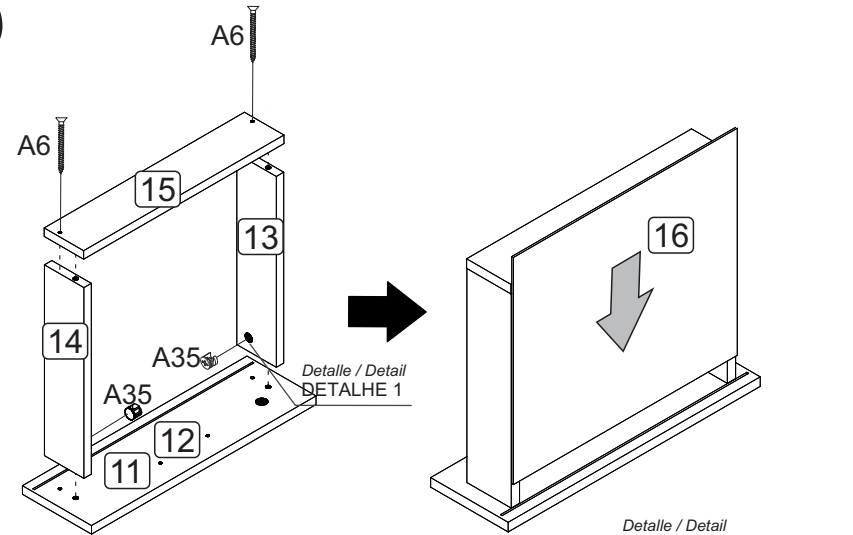

Detalle / Detail  
DETALHE 1

Depois de encaixar as peças coloque o tambor com a sua seta voltada para o parafuso. Para apertar Gire no sentido horário.  
Después de colocar las piezas, coloque el tambor con su flecha hacia el tornillo. Para apretar, gire en sentido horario.  
After fitting the parts, place the drum with its arrow facing the screw. To tighten, turn clockwise.

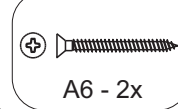

A6 - 2x



A35 - 2x



F1 - 2x