

## Capacidade de Carga - Load Capacity - Capacidad de carga

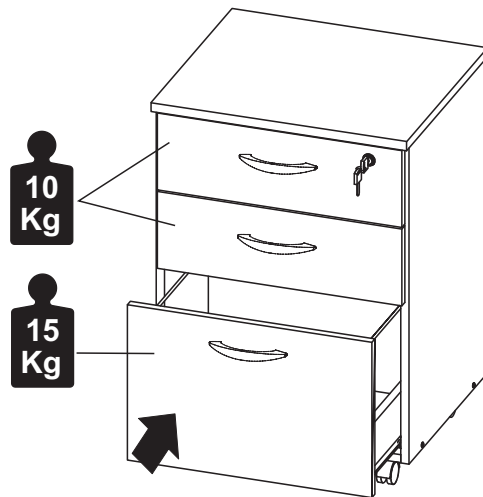

### Manutenção e Limpeza

Vidros: pano levemente umedecido com álcool, seguido de pano seco.  
Madeiras: pano levemente umedecido com água, seguido de pano seco.  
\*Nunca utilizar produtos químicos ou abrasivos.

### Maintenance and Cleaning

Glasses: cloth lightly moistened with alcohol, followed by dry cloth.  
Woods: cloth slightly moistened with water, followed by cloth seco.  
\*Never use chemicals or abrasives.

### Mantenimiento y Limpieza

Vidrios: legeramente humedecido con alcohol, seguido de un paño seco.  
Madera: ligeramente humedecido con agua, seguido de un paño seco.  
\*No utilice nunca productos químicos o abrasivos.

## Certificado de garantia

A garantia dos produtos fabricados pela Gebb Work Indústria de Móveis LTDA, abrange eventuais defeitos de fabricação, no prazo estabelecido pelo Código de Defesa do Consumidor, em seu artigo 26, II, o qual prevê a garantia legal de 90 (noventa) dias.

## INSTRUÇÕES DE MONTAGEM ASSEMBLY INSTRUCTIONS INSTRUCCIONES DE MONTAJE

### GAVETEIRO 02 GAVETAS E 01 PASTA SUSPENSA DRAWER 02 DRAWERS AND 01 SUSPENDED FOLDER CAJONERO 02 CAJONES E 04 CARPETAS SUSPENDIDOS

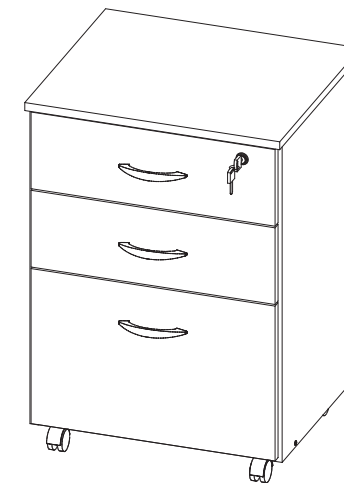

1 P.



30mim

REF. #0319

 **Gebbwork**

MOBILIÁRIO  
PARA ESCRITÓRIO

GEBB Work Ind. de Móveis Ltda.  
Rua Felix Roman, 190  
São Valentin

95709-170 - Bento Gonçalves - RS - Brasil  
Fone: (0XX54) 3454-1105 - (0XX54) 3453-1407  
Phone: (0XX54) 3454-1105 - (0XX54) 3453-1407  
E-mail: [pedidos@gebbwork.com.br](mailto:pedidos@gebbwork.com.br)

[www.gebbwork.com.br](http://www.gebbwork.com.br)

WhatsApp: +55 54 99177-8324

## LISTA DE PEÇAS

### LISTA DE PEÇAS

- 01 - Lateral Esquerda
- 02 - Lateral Direita
- 03 - Tampo
- 04 - Base Frontal
- 05 - Frente Pasta
- 06 - Fundo Gaveta
- 07 - Lateral Esquerda Gaveta
- 08 - Lateral Direita Gaveta
- 09 - Costa Pasta
- 11 - Costa
- 12 - Frente Gaveta
- 13 - Frente Gaveta c/ Fechadura
- 14 - Costa Gaveta
- 15 - Base Traseira

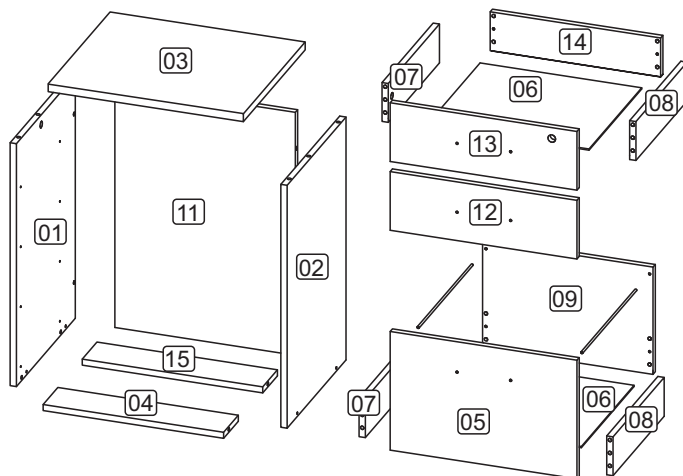

### LISTA DE PIEZAS

- 01 - Lateral Izquierda
- 02 - Lateral Derecha
- 03 - Tapa
- 04 - Base Frente
- 05 - Frente Cajón
- 06 - Fondo Cajón
- 07 - Lateral Izquierda Cajón
- 08 - Lateral Derecha Cajón
- 09 - Revés Cajón
- 11 - Revés
- 12 - Frente Cajón
- 13 - Frente Cajón c/ Tranca
- 14 - Revés Cajón
- 15 - Base en la Espalda

### PARTS IDENTIFICATION

- 01 - Left Side
- 02 - Right Side
- 03 - Top
- 04 - Front Base
- 05 - Drawer Front
- 06 - Drawer Bottom
- 07 - Left Drawer Side
- 08 - Right Drawer Side
- 09 - Drawer Back
- 11 - Back
- 12 - Drawer Front
- 13 - Front Drawer Locks
- 14 - Drawer Back
- 15 - Base on Back

## 6 (1x)

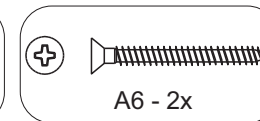
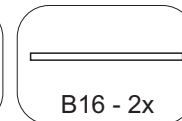
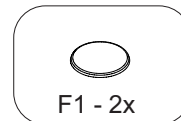
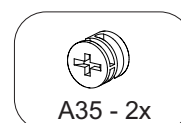
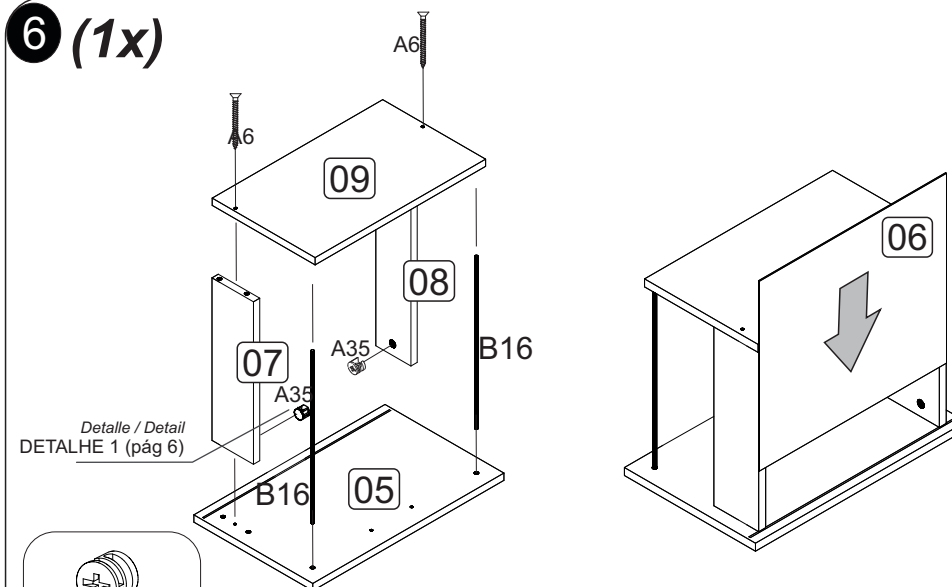

## 7 (1x)

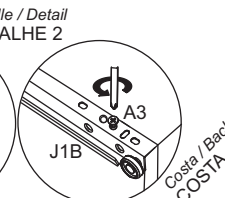
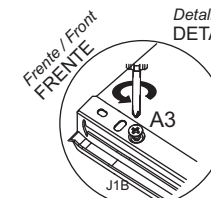
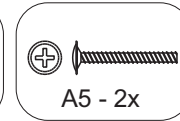
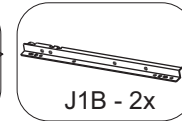
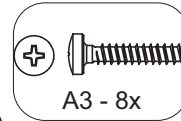
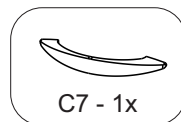
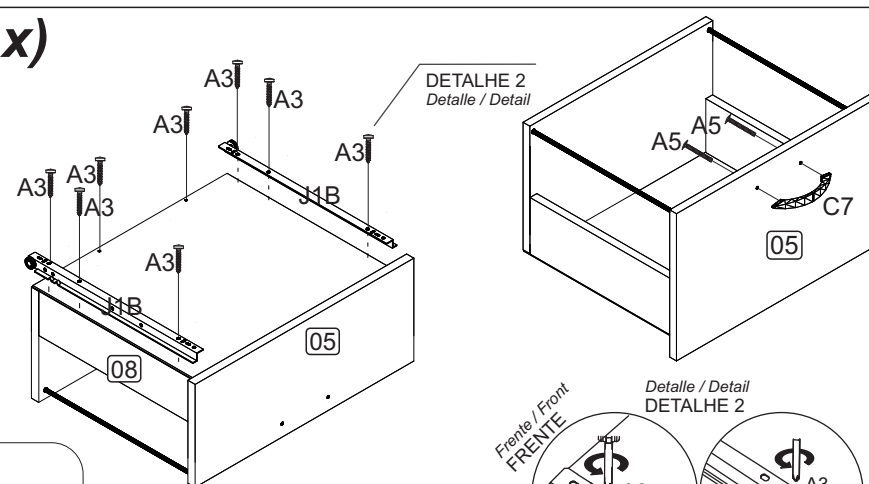

Identifique o esquerdo e o direito. Rolamento voltado para costa e parafusado por baixo da gaveta através do fundo e laterais.  
 Identifica la izquierda y la derecha. Rodamiento frente a la costa y atornillado debajo del cajón por el fondo y los lados.  
 Identify the left and the right. Bearing facing the coast and screwed under the drawer through the bottom and sides.

# 5 (2x)

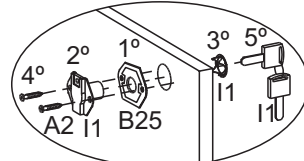
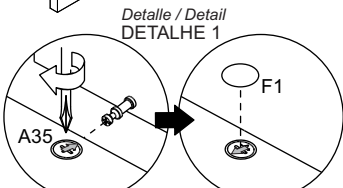
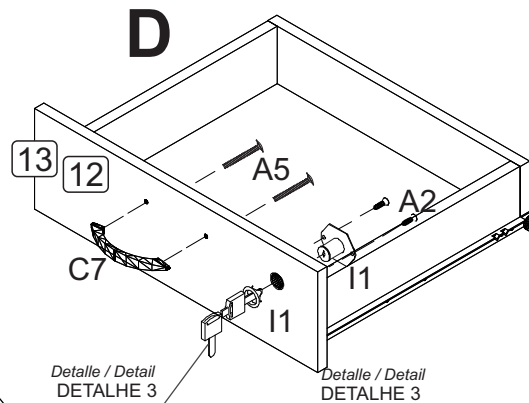
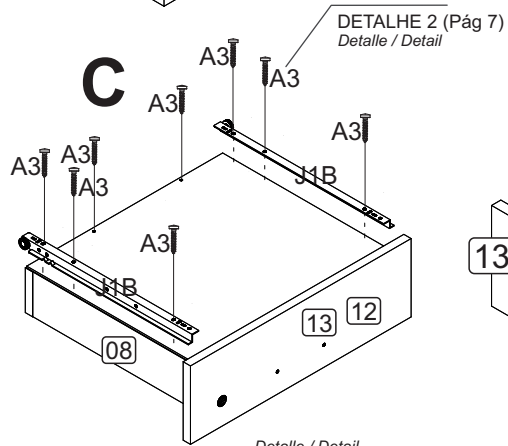
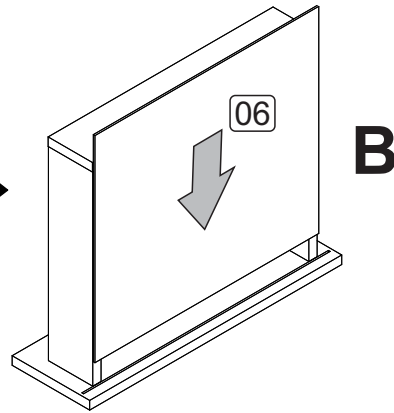
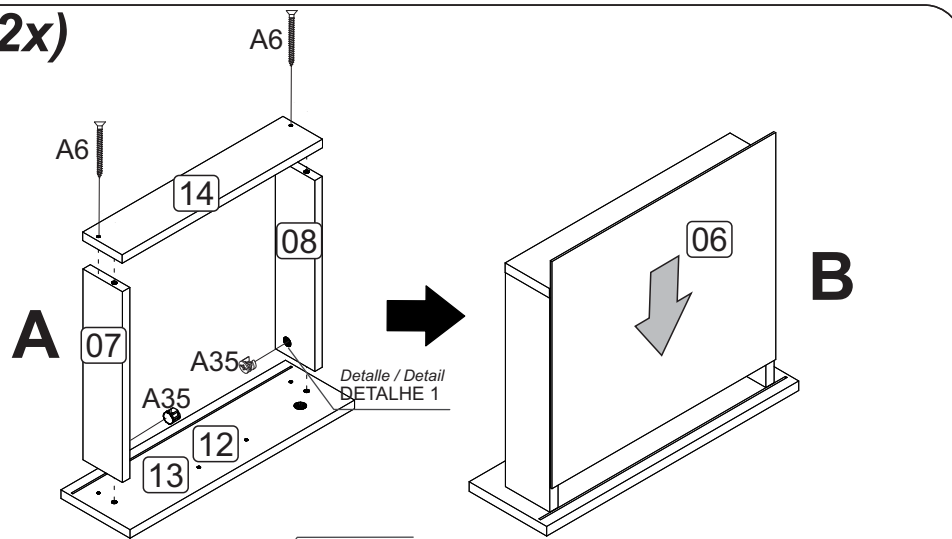

Depois de encaixar as peças coloque o tambor com a sua seta voltada para o parafuso. Para apertar gire no sentido horário.  
 Después de colocar las piezas, coloque el tambor con su flecha hacia el tornillo. Para apretar, gire en sentido horario.  
 After fitting the parts, place the drum with its arrow facing the screw. To tighten, turn clockwise.

Siga a ordem crescente de instalação.  
 Siga el orden ascendente de instalación.  
 Follow the ascending order of installation.

- |  |  |  |  |  |
|--|--|--|--|--|
|  |  |  |  |  |
|  |  |  |  |  |

# ACESSÓRIOS ACCESSORIES ACCESORIOS

A2 - PARAF. 3,5x14 CC  
32x



A5 - PARAF. 3,5x25 CF  
6x



A6 - PARAF. 3,5x40 CC  
6x



A17 - PARAF. 4,0x45 CF  
4x



A32 - PARAF. MINIFIX  
8x

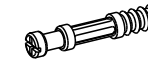

A3 - PARAF. 3,5x20 CP  
24x



B16 - HASTE MET.  
353mm 2x



C2 - KIT 4 RODÍZIOS  
RB40 1x



C7 - PUXADOR  
3x



D1 - CAVILHA 8x30  
36x

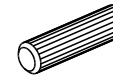

F1 - TAPA FURO ø18  
8x



I1 - FECHADURA P/GAV.  
1x



B25 - SEPARADOR PARA  
FECHADURA 1x



J1 - CORREDIÇA 350mm  
3x



M2 - CHAPA L 2 FUROS  
OBL 42x17x0,9mm ZB 1x



A35 - TAMBOR  
MINIFIX 8x



Medir os acessórios na régua abaixo.

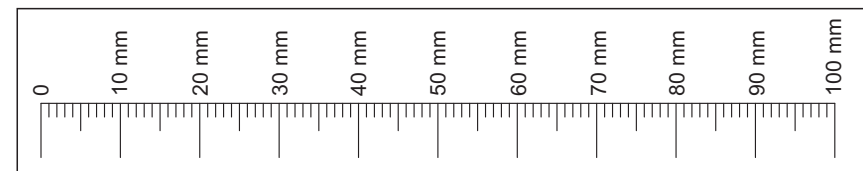

# 1 PRÉ-MONTAGEM

Preassembla  
Pre-assembly

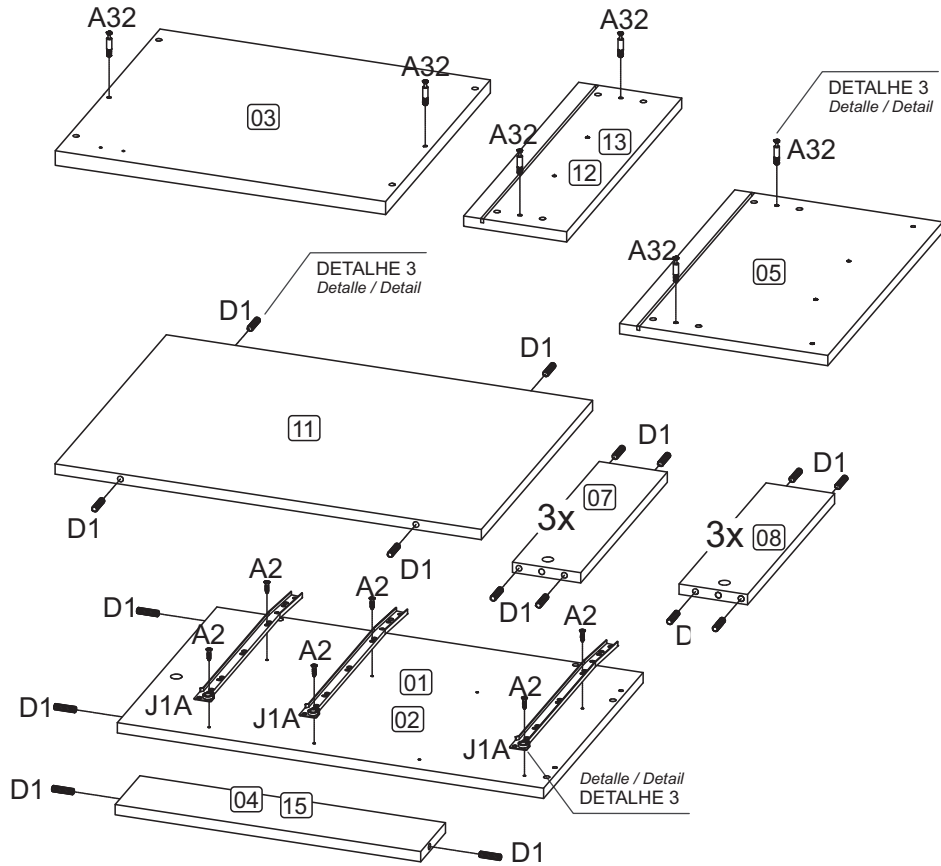

Detalle / Detail  
DETALHE 1

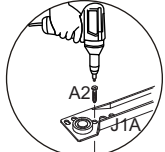

Detalle / Detail  
DETALHE 2



Detalle / Detail  
DETALHE 3

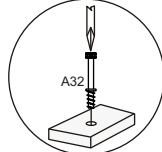

Pressione até o fundo do furo.  
Se necessário utilize um martelo de borracha.  
Presione hasta el fondo del agujero.  
Si es necesario, utilice un mazo de goma.  
Press to the bottom of the hole.  
If necessary use a rubber mallet.

Coloque sobre as marcações e parafuse no 'x'.  
Coloque sobre las marcas y atornille la 'x'.  
Place over the markings and screw in the 'x'.

Parafuse com uma chave de fenda cruzada.  
Atornille con un destornillador cruzado.  
Screw with a crossed screwdriver.

04/08

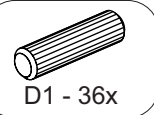
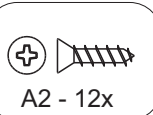
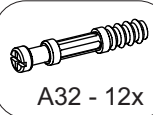

# 2 MONTAGEM

Armado  
Assembly

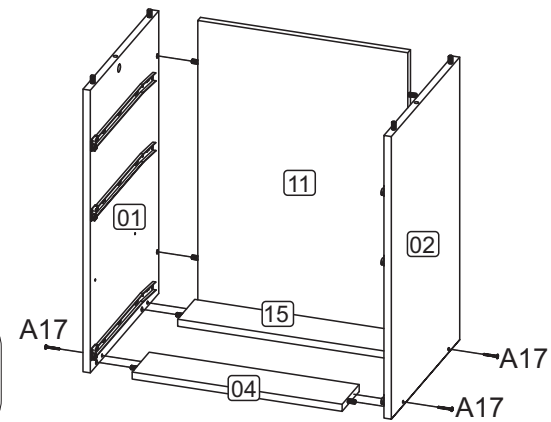
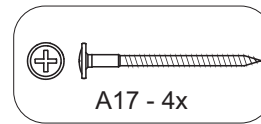

# 3

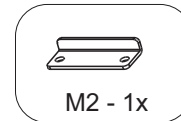
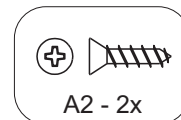

Detalle / Detail  
DETALHE 1 (pág 6)

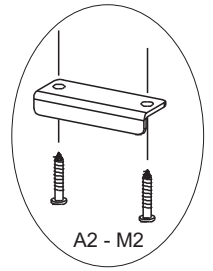
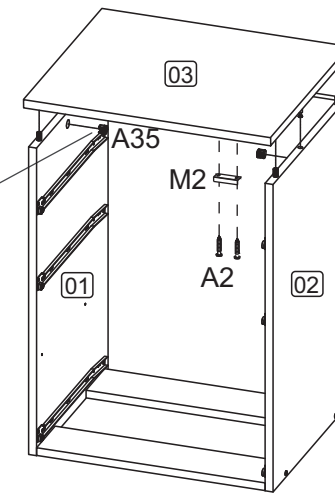

# 4

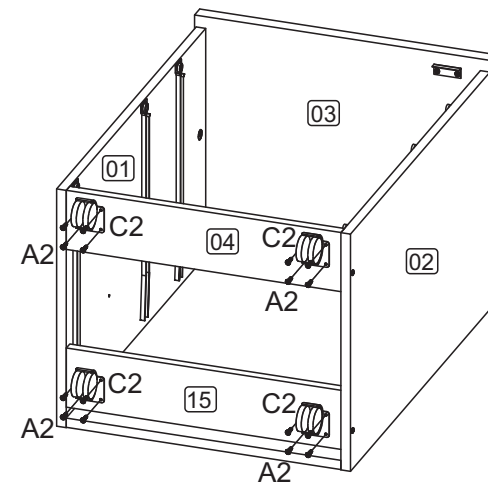
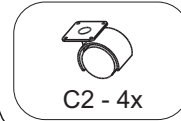
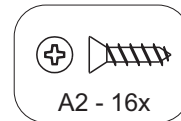

05/08