

Capacidade de Carga - Load Capacity - Capacidad de carga

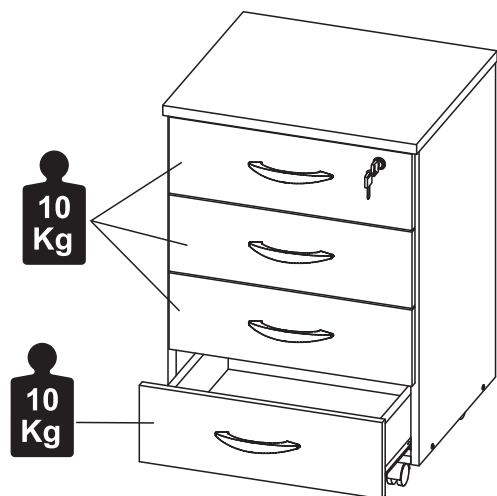

Manutenção e Limpeza

Vidros: pano levemente umedecido com álcool, seguido de pano seco.
Madeiras: pano levemente umedecido com água, seguido de pano seco.
*Nunca utilizar produtos químicos ou abrasivos.

Maintenance and Cleaning

Glasses: cloth lightly moistened with alcohol, followed by dry cloth.
Woods: cloth slightly moistened with water, followed by cloth seco.
*Never use chemicals or abrasives.

Mantenimiento y Limpieza

Vidrios: legeramente humedecido con alcohol, seguido de un paño seco.
Madera: ligeramente humedecido con agua, seguido de un paño seco.
*No utilice nunca productos químicos o abrasivos.

Certificado de garantia

A garantia dos produtos fabricados pela Gebb Work Indústria de Móveis LTDA, abrange eventuais defeitos de fabricação, no prazo estabelecido pelo Código de Defesa do Consumidor, em seu artigo 26, II, o qual prevê a garantia legal de 90 (noventa) dias.

INSTRUÇÕES DE MONTAGEM ASSEMBLY INSTRUCTIONS INSTRUCCIONES DE MONTAJE

GAVETEIRO 04 GAVETAS DRAWER 04 DRAWERS CAJONERO 04 CAJONES

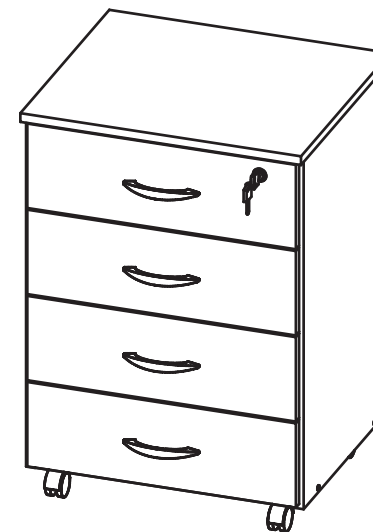

1 P.



30mim

REF. #0320

 **Gebbwork**

MOBILIÁRIO
PARA ESCRITÓRIO

GEBB Work Ind. de Móveis Ltda.
Rua Felix Roman, 190
São Valentin

95709-170 - Bento Gonçalves - RS - Brasil
Fone: (0XX54) 3454-1105 - (0XX54) 3453-1407
Phone: (0XX54) 3454-1105 - (0XX54) 3453-1407
E-mail: pedidos@gebbwork.com.br

www.gebbwork.com.br

WhatsApp: +55 54 99177-8324

LISTA DE PEÇAS

LISTA DE PEÇAS

- 01 - Lateral Esquerda
- 02 - Lateral Direita
- 03 - Tampo
- 04 - Base Frontal
- 06 - Fundo Gaveta
- 07 - Lateral Esquerda Gaveta
- 08 - Lateral Direita Gaveta
- 11 - Costa
- 12 - Frente Gaveta
- 13 - Frente Gaveta c/ Fechadura
- 14 - Costa Gaveta
- 15 - Base Traseira

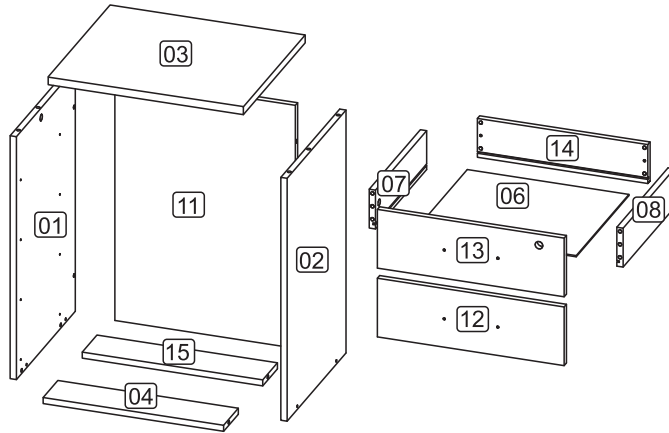

LISTA DE PIEZAS

- 01 - Lateral Izquierda
- 02 - Lateral Derecha
- 03 - Tapa
- 04 - Base Frente
- 06 - Fondo Cajón
- 07 - Lateral Izquierda Cajón
- 08 - Lateral Derecha Cajón
- 11 - Revés
- 12 - Frente Cajón
- 13 - Frente Cajón c/ Tranca
- 14 - Revés Cajón
- 15 - Base en la Espalda

PARTS IDENTIFICATION

- 01 - Left Side
- 02 - Right Side
- 03 - Top
- 04 - Front Base
- 06 - Drawer Bottom
- 07 - Left Drawer Side
- 08 - Right Drawer Side
- 11 - Back
- 12 - Front Drawer
- 13 - Front Drawer Locks
- 14 - Drawer Back
- 15 - Base on Back

5(4x)

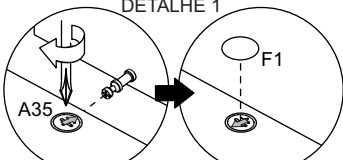
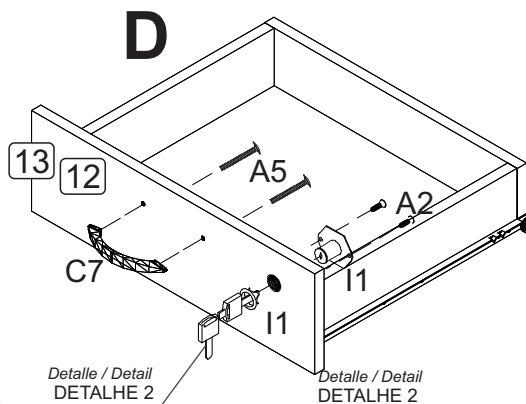
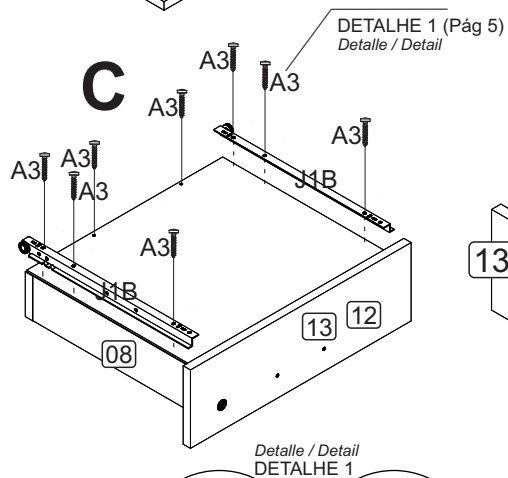
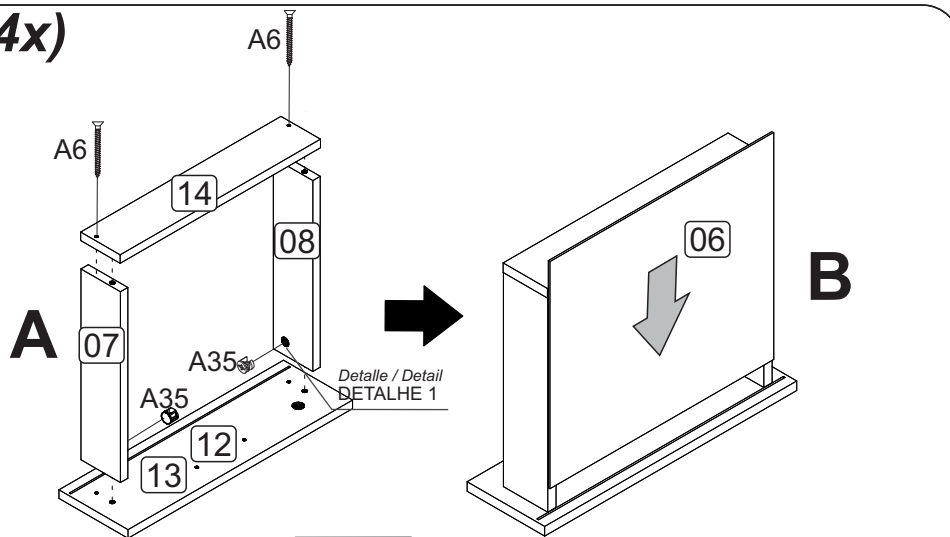

Depois de encaixar as peças coloque o tambor com a sua seta voltada para o parafuso. Para apertar gire no sentido horário.
 Después de colocar las piezas, coloque el tambor con su flecha hacia el tornillo. Para apretar, gire en sentido horario.
 After fitting the parts, place the drum with its arrow facing the screw. To tighten, turn clockwise.

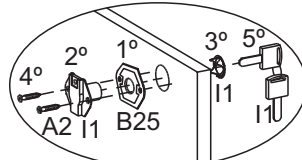

Siga a ordem crescente de instalação.
 Siga el orden ascendente de instalación.
 Follow the ascending order of installation.

- | | | | | |
|--|--|--|--|--|
| | | | | |
| | | | | |

ACESSÓRIOS ACCESSORIES ACCESORIOS

A2 - PARAF. 3,5x14 CC
36x



A5 - PARAF. 3,5x25 CF
8x



A6 - PARAF. 3,5x40 CC
8x



A17 - PARAF. 4,0x45 CF
4x



A32 - PARAF. MINIFIX
10x

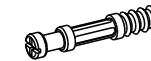

A3 - PARAF. 3,5x20 CP
32x



C2 - KIT 4 RODÍZIOS
RB40 **4x**



C7 - PUXADOR
4x



D1 - CAVILHA 8x30
44x

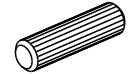

F1 - TAPA FURO ø18
8x



I1 - FECHADURA P/GAV.
1x



B25 - SEPARADOR PARA
FECHADURA **1x**



J1 - CORREDIÇA 350mm
4x



M2 - CHAPA L 2 FUROS
OBL 42x17x0,9mm ZB **1x**



A35 - TAMBOR
MINIFIX **10x**



Medir os acessórios na régua abaixo.

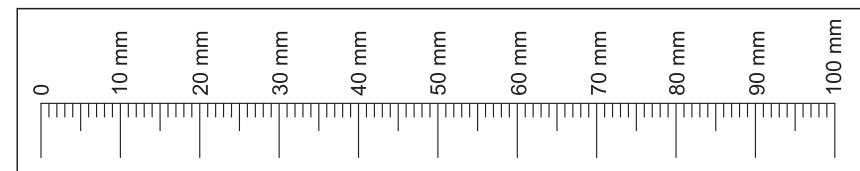

1

PRÉ-MONTAGEM

Preassembla
Pre-assembly

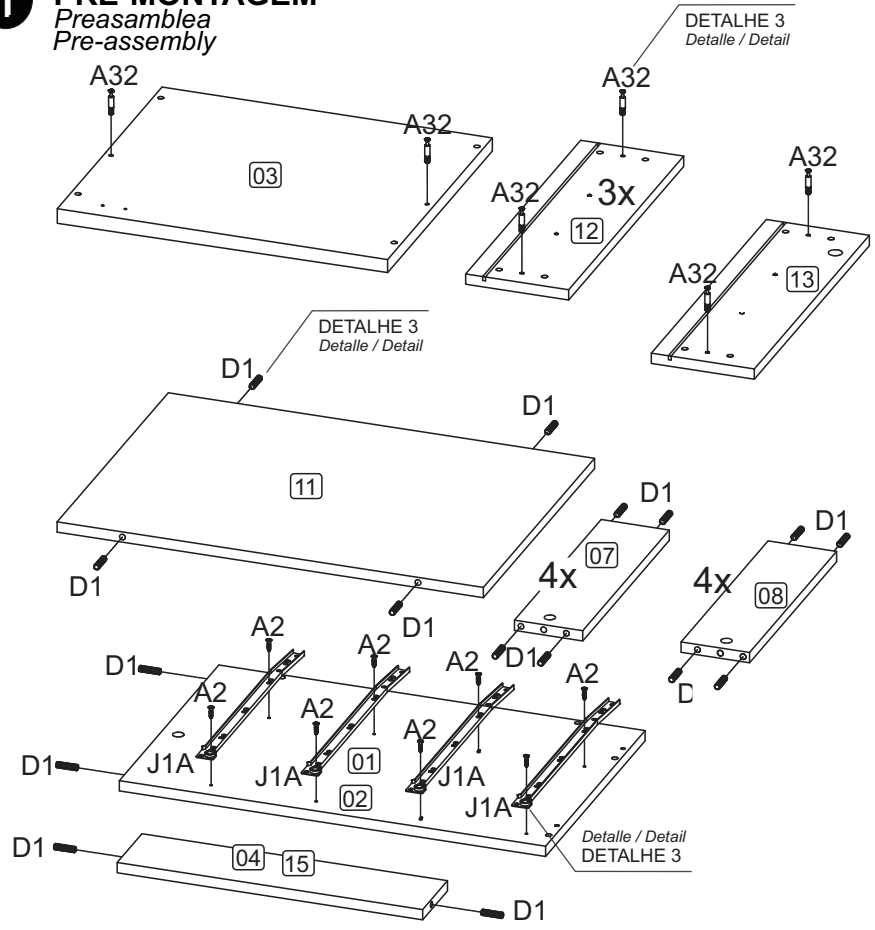

DETALHE 3
Detalle / Detail

DETALHE 3
Detalle / Detail

DETALHE 3
Detalle / Detail

DETALHE 1
Detalle / Detail

DETALHE 2
Detalle / Detail

DETALHE 3
Detalle / Detail

Coloque sobre as marcações e parafuse no 'x'.
Coloque sobre las marcas y atornille la 'x'.
Place over the markings and screw in the 'x'.

Pressione até o fundo do furo.
Se necessário utilize um martelo de borracha.
Presione hasta el fondo del agujero.
Si es necesario, utilice un mazo de goma.

Parafuse com uma chave de fenda cruzada.
Atornille con un destornillador cruzado.
Screw with a crossed screwdriver.

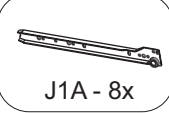
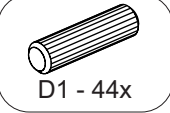
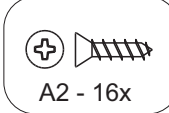
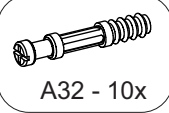

2

MONTAGEM

Armado
Assembly

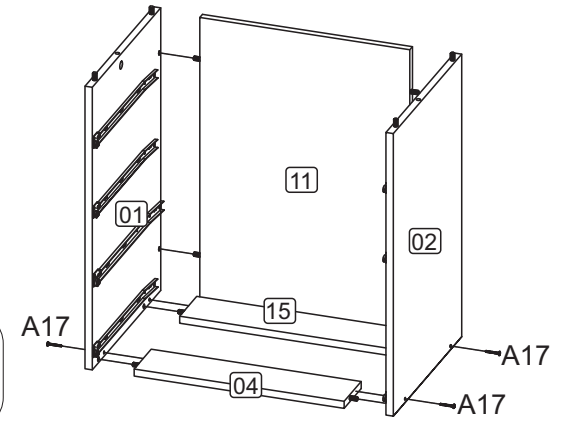
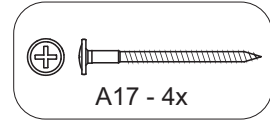

3

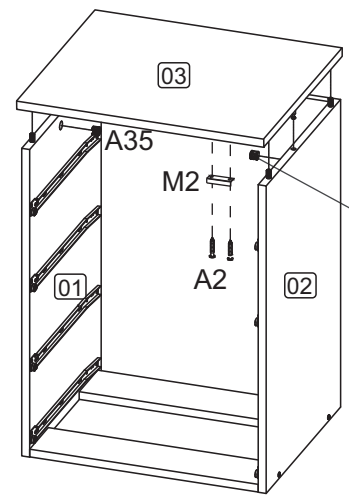
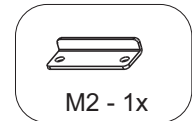
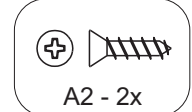

DETALHE 1 (pág 6)
Detalle / Detail

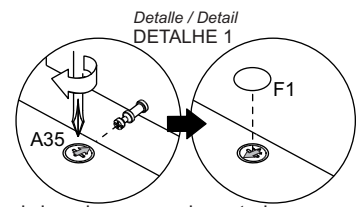

Depois de encaixar as peças coloque o tambor com a sua seta voltada para o parafuso. Para apertar Gire no sentido horário.
Después de colocar las piezas, coloque el tambor con su flecha hacia el tornillo. Para apretar, gire en sentido horario.
After fitting the parts, place the drum with its arrow facing the screw. To tighten, turn clockwise.

4

