

Capacidade de Carga - Load Capacity - Capacidad de carga

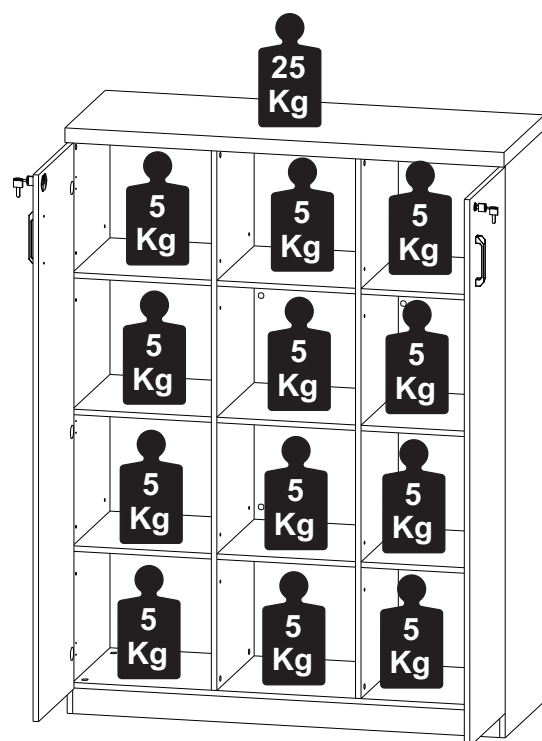

Manutenção e Limpeza

Vidros: pano levemente umedecido com álcool, seguido de pano seco.
Madeiras: pano levemente umedecido com água, seguido de pano seco.
*Nunca utilizar produtos químicos ou abrasivos.

Maintenance and Cleaning

Glasses: cloth lightly moistened with alcohol, followed by dry cloth.
Woods: cloth slightly moistened with water, followed by cloth seo.
*Never use chemicals or abrasives.

Mantenimiento y Limpieza

Vidrios: legeramente humedecido con alcohol, seguido de un paño seco.
Madera: ligeramente humedecido con agua, seguido de un paño seco.
*No utilice nunca productos quimicos o abrasivos.

INSTRUÇÕES DE MONTAGEM ASSEMBLY INSTRUCTIONS INSTRUCCIONES DE MONTAJE

ARMÁRIO ALTO HIGT CABINET ARMARIO ALTO

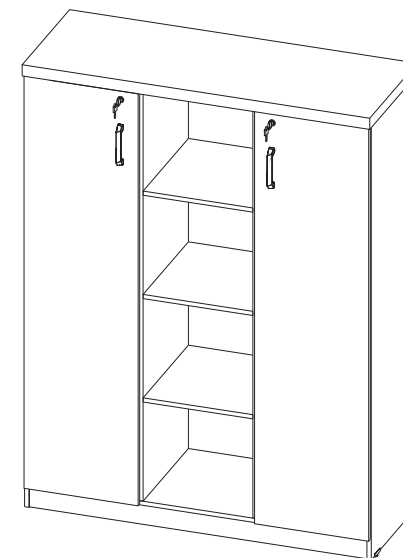

REF. #SAT1216-EXP1221

 **Gebbwork**

MOBILIÁRIO
PARA ESCRITÓRIO

GEBB Work Ind. de Móveis Ltda.
Rua Felix Roman, 190
São Valentin

95709-170 - Bento Gonçalves - RS - Brasil
Fone: (0XX54) 3454-1105 - (0XX54) 3453-1407
Phone: (0XX54) 3454-1105 - (0XX54) 3453-1407

E-mail: pedidos@gebbwork.com.br

www.gebbwork.com.br

WhatsApp: +55 54 99177-8324

LISTA DE PEÇAS

- 01 - Lateral Esquerda
- 02 - Lateral Direita
- 03 - Tampo
- 04 - Base
- 05 - Prateleira
- 06 - Porta Esquerda
- 07 - Porta Direita
- 08 - Costa
- 09 - Rodapé
- 10 - Prateleira Móvel
- 11 - Divisória

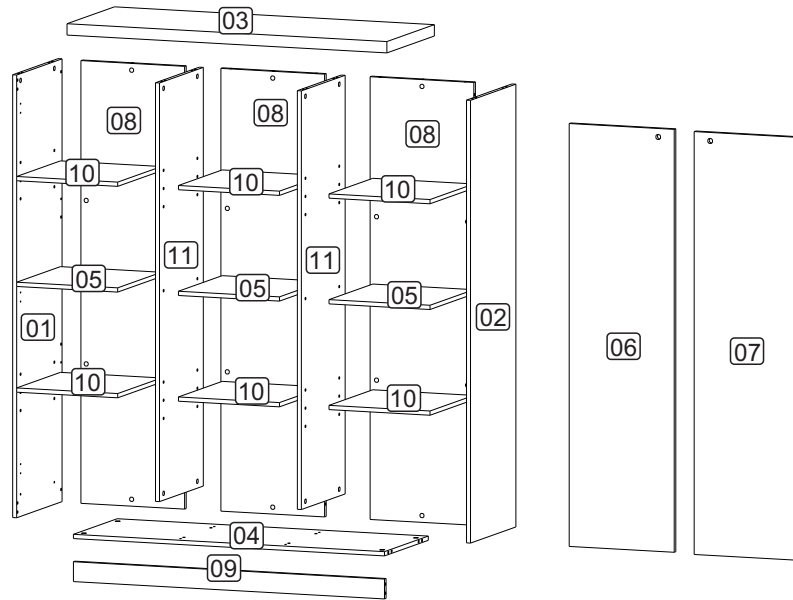

LISTA DE PIEZAS

- 01 - Lateral Izquierda
- 02 - Lateral Derecha
- 03 - Tapa
- 04 - Base
- 05 - Plataforma
- 06 - Puerta Izquierda
- 07 - Puerta Derecha
- 08 - Revés
- 09 - Pie
- 10 - Plataforma Muevel
- 11 - Divisória

PARTS IDENTIFICATION

- 01 - Left Side
- 02 - Right Side
- 03 - Top
- 04 - Base
- 05 - Shelf
- 06 -Left Door
- 07 - Right Door
- 08 - Back
- 09 - Footer
- 10 - Shelf
- 11 - Division

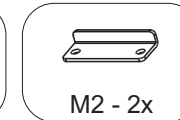
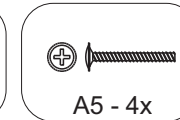
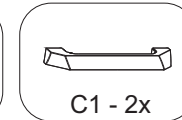
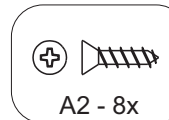
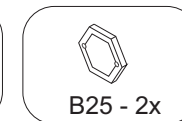
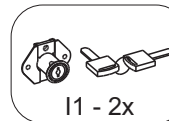
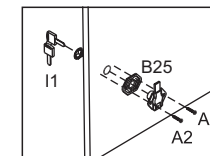
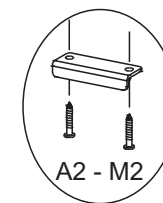
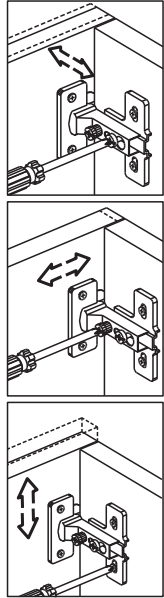
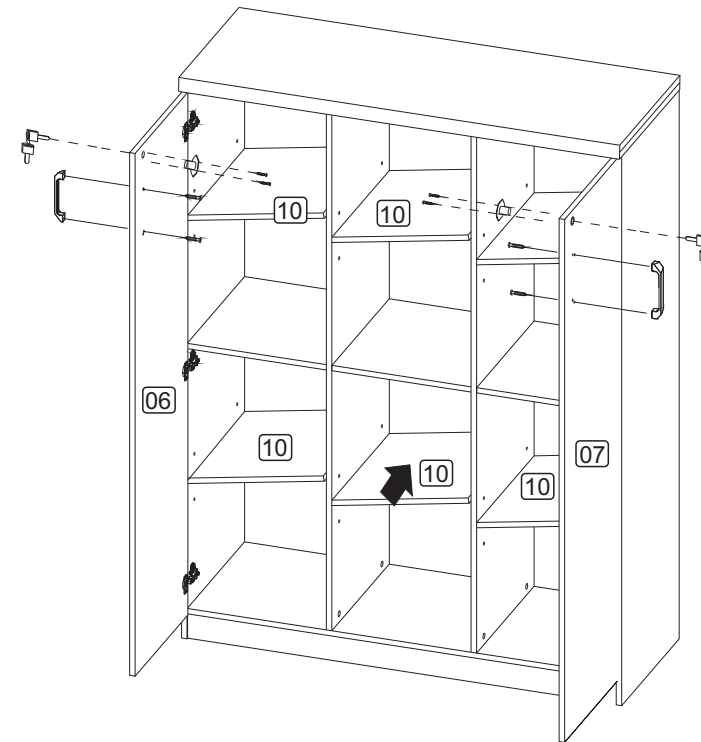

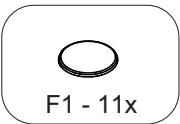
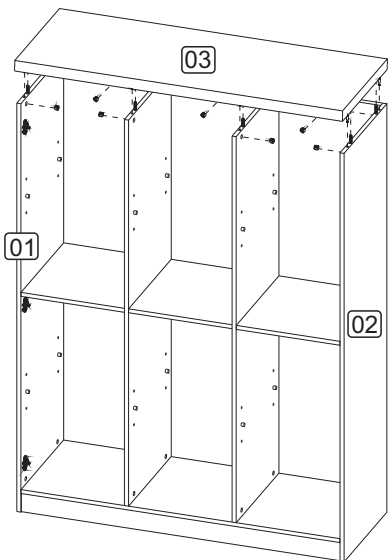
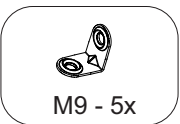
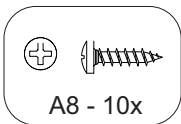
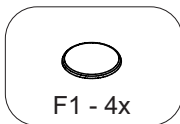
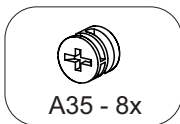
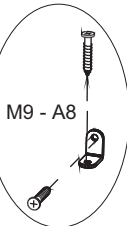
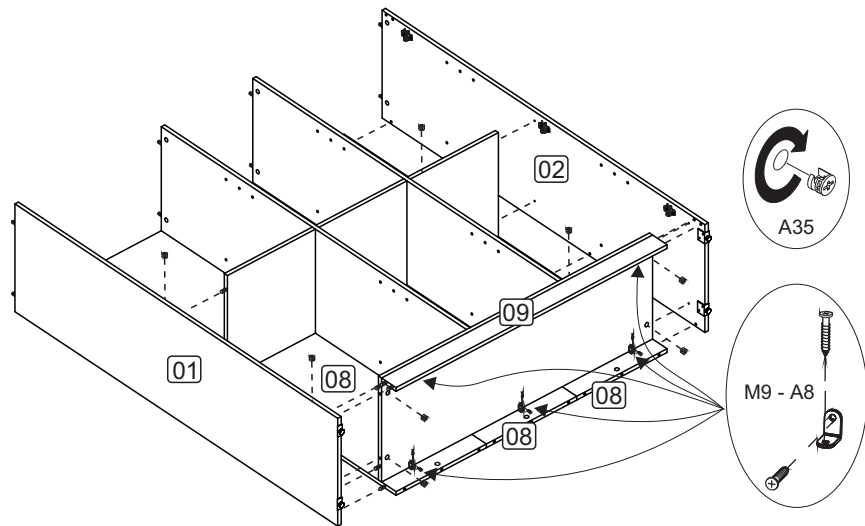

ACESSÓRIOS ACCESSORIES ACCESORIOS

A2 - PARAF. 3,5x14 CC
8x



A5 - PARAF. 3,5x25 CF
4x



A8 - PARAF. 4,0x14 CP
44x



A32 - PARAF. MINIFIX
27x

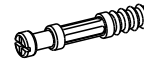

A33 - PARAF. MINIFIX DP
4x

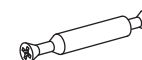

A34 - HASTE MINIFIX
DUPLO P/15mm **4x**

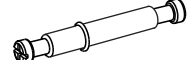

A35 - TAMBOR
MINIFIX **43x**



B2 - SUPORTE PRAT.
24x



C1 - PUXADOR
2x



D1 - CAVILHA 8x30
34x

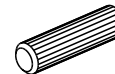

D2 - CAVILHA 8x40
12x

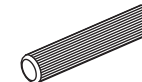

F1 - TAPA FURO \varnothing 18
27x



F2 - TAPA FURO PLÁST
ENCAIXE 8mm **52x**



I1 - FECHADURA P/GAV.
2x



G2 - CALÇO ALTO P/
DOBRADIÇA **6x**



G3 - DOBRADIÇA 35
BAIXO **6x**

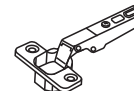

L3 - SAPATA PLAST.1/4
5x



M1 - SUPORTE L PARA
SAPATA **5x**



M2 - CHAPA L 2 FUROS
OBL 42x17x0,9mm ZB **2x**

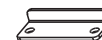

M9 - CANTONEIRA L
02 FUROS **5x**



B25 - SEPARADOR
P/ FECHADURA **2x**



