

#### Manutenção e Limpeza

Vidros: pano levemente umedecido com álcool, seguido de pano seco.  
Madeiras: pano levemente umedecido com água, seguido de pano seco.  
\*Nunca utilizar produtos químicos ou abrasivos.

#### Maintenance and Cleaning

Glasses: cloth lightly moistened with alcohol, followed by dry cloth.  
Woods: cloth slightly moistened with water, followed by cloth seo.  
\*Never use chemicals or abrasives.

#### Mantenimiento y Limpieza

Vidrios: legeramente humedecido con alcohol, seguido de un paño seco.  
Madera: ligeramente humedecido con agua, seguido de un paño seco.  
\*No utilice nunca productos quimicos o abrasivos.

# INSTRUÇÕES DE MONTAGEM ASSEMBLY INSTRUCTIONS INSTRUCCIONES DE MONTAJE PAINEL PAREDE WALL PANEL PANEL PARED

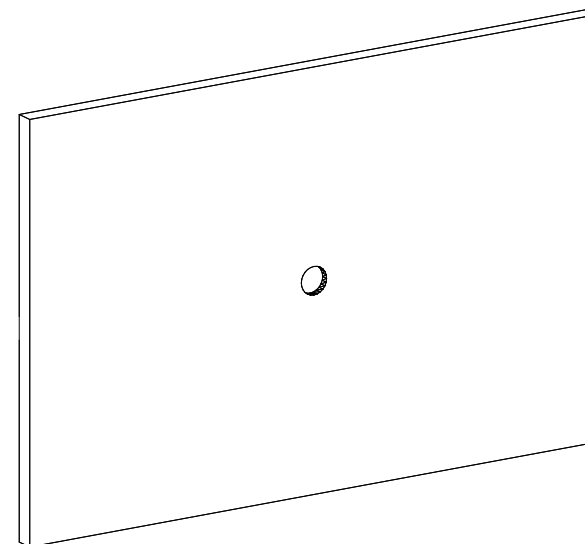

1 P.



45mim

REF.: #SAT1390



MOBILIÁRIO  
PARA ESCRITÓRIO

GEBB Work Ind. de Móveis Ltda.  
Rua Felix Roman, 190  
São Valentin

95709-170 - Bento Gonçalves - RS - Brasil  
Fone: (0XX54) 3454-1105 - (0XX54) 3453-1407  
Phone: (0XX54) 3454-1105 - (0XX54) 3453-1407

E-mail: [pedidos@gebbwork.com.br](mailto:pedidos@gebbwork.com.br)

[www.gebbwork.com.br](http://www.gebbwork.com.br)

WhatsApp: +55 54 99177-8324

## LISTA DE PEÇAS

- 01 - Painel Engrossurado 40mm  
02 - Travessa Encaixe

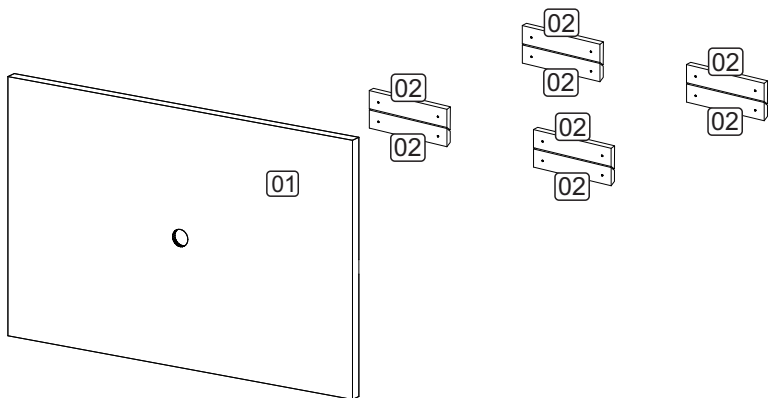

## LISTA DE PIEZAS

- 01 - Panel Engros. 40mm  
02 - Listón Adequado

## PARTS IDENTIFICATION

- 01 - Panel Bulky 40mm  
02 - Traverse Fitting

## ACESSÓRIOS ACCESSORIES ACCESORIOS

A14 - PARAF. 4,0x35 CC  
8x



A25 - PARAF. 6,0x80 CC  
8x



B20 - BUCHA NYLON  
UX 8x50 8x



T11 - PASSA CABO GEBB  
60MM 1x



## GABARITO DE POSICIONAMENTO.

Plantilla de posicionamiento.  
Positioning template.



NÍVEL  
(NÃO FORNECIDO)  
Nivel (no proporcionado).  
Level (Not provided).

### TRAVESSAS FIXADAS NO PAINEL

Platos unidos al panel / Platters attached to the panel

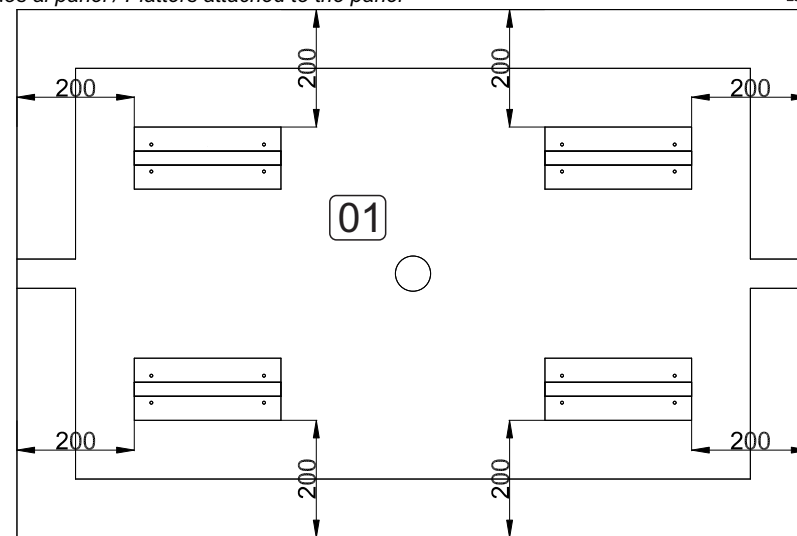

### TRAVESSAS FIXADAS NA PAREDE

Platos unidos a pared / Platters attached to the wall

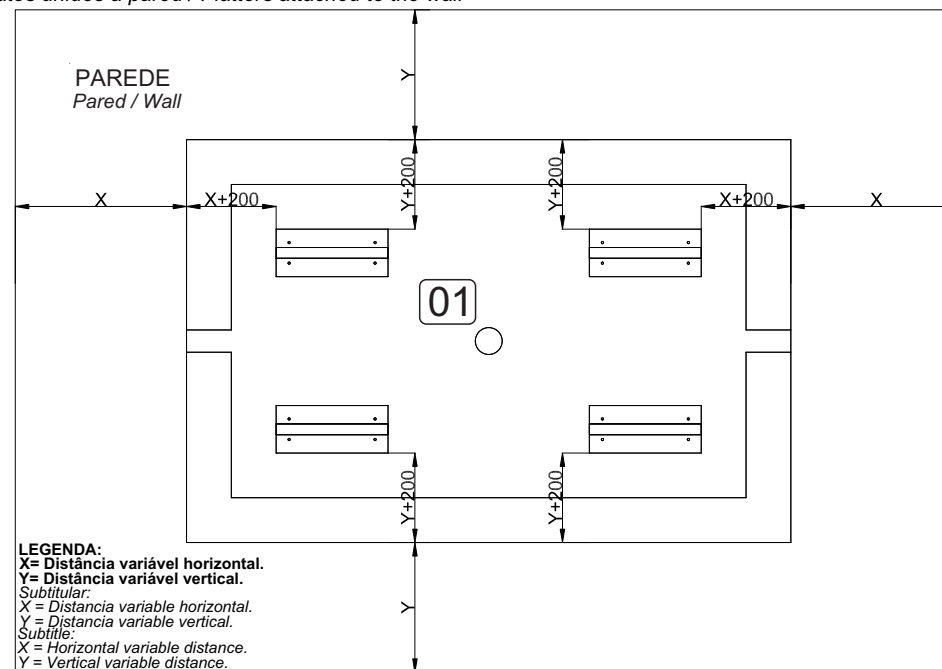

LEGENDA:  
X= Distância variável horizontal.  
Y= Distância variável vertical.  
Subtitular:  
X = Distancia variable horizontal.  
Y = Distancia variable vertical.  
Subtite:  
X = Horizontal variable distance.  
Y = Vertical variable distance.

Em milímetros / En milímetros / In millimeters

#### 4 ENCAIXE AS TRAVESSAS '02' FIXADAS NO PAINEL '01' NAS TRAVESSAS '02' FIXADAS NA PAREDE. POR FIM, ENCAIXE O PASSA CABOS 'T11' NO PAINEL '01'.

Montar las traviesas '02' fijadas en lo panel '01' a las traviesas '02' fijadas a la pared. Finalmente, coloque el prensaestopas 'T11' en el panel '01'.  
Fit the '02' sleepers fixed on the panel '01' to the sleepers '02' fixed on the wall. Finally, fit the cable gland 'T11' to the panel '01'.

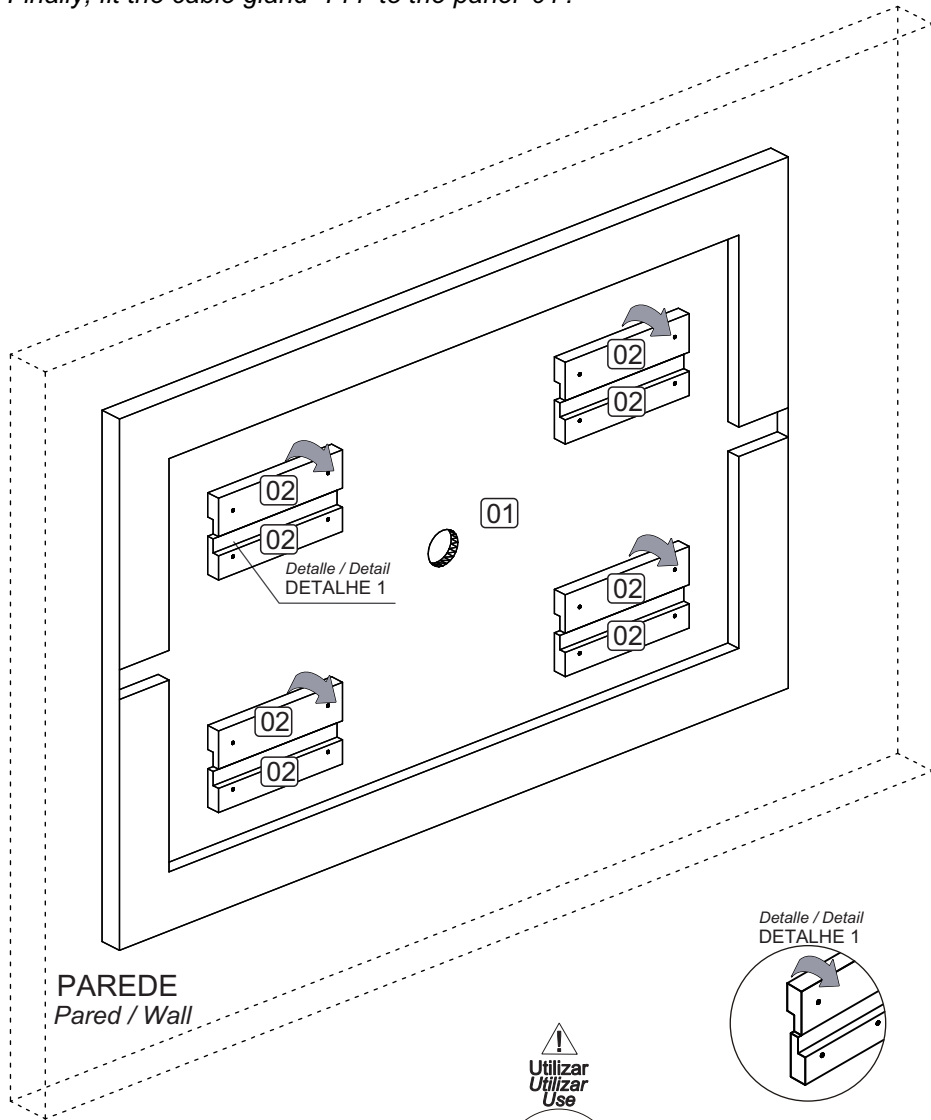

#### 1 MONTAGEM.

Armado.  
Assembly.

#### GABARITO DE POSICIONAMENTO NA PÁGINA 07.

Plantilla de posicionamiento en la página 07.  
Positioning template on page 07.

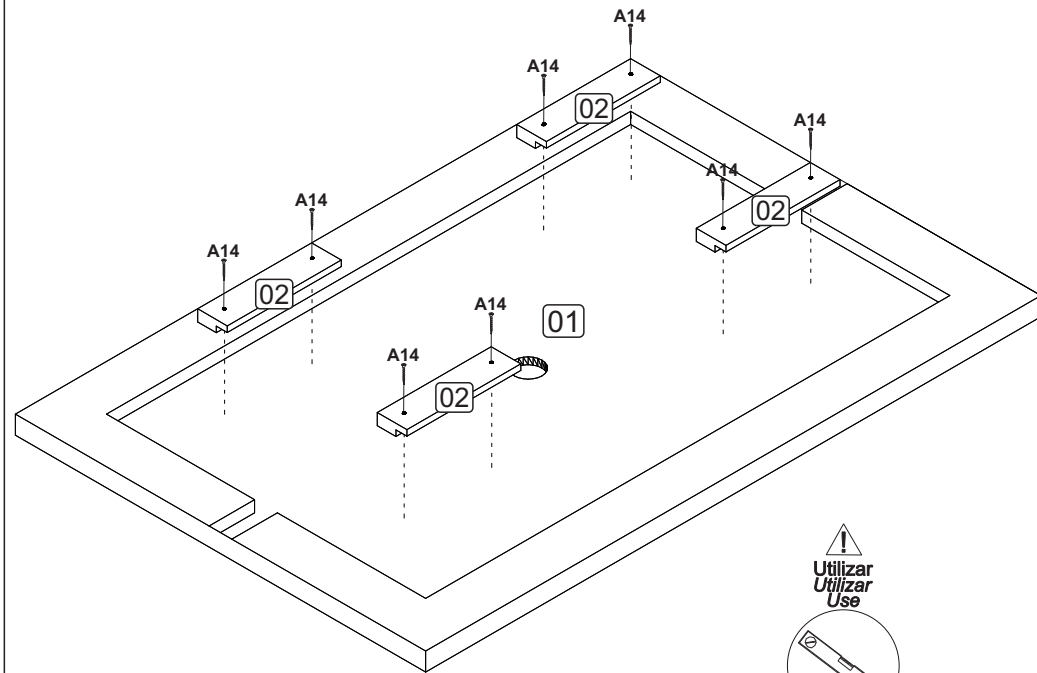

A14 - 8x

## 2 PERFURAÇÃO DA PAREDE.

Perforación de la pared.  
Perforation of the wall.

GABARITO DE POSICIONAMENTO NA PÁGINA 07.

Plantilla de posicionamiento en la página 07.  
Positioning template on page 07.

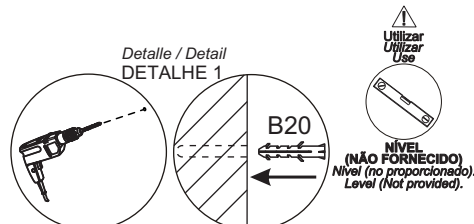
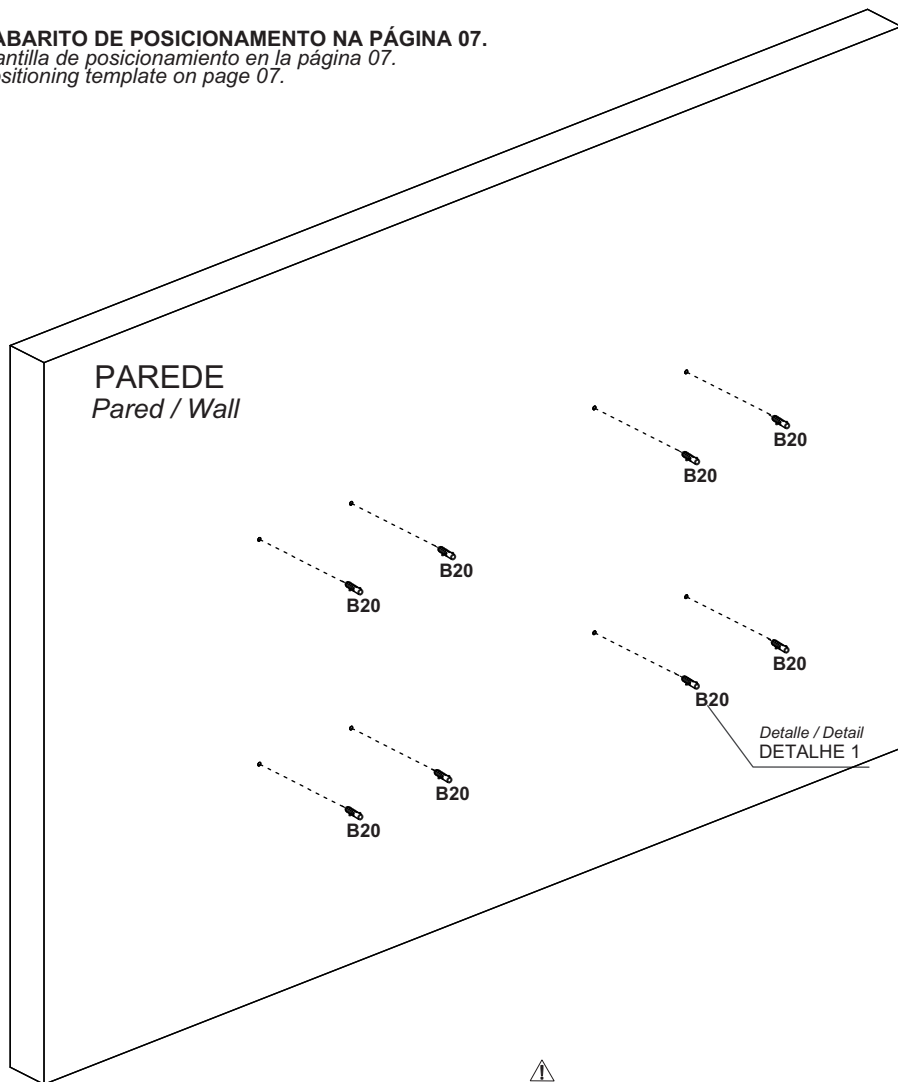

Com uma furadeira com broca de 8mm (não fornecida), fazer os furos na parede e encaixar as buchas plásticas.  
Con una taladradora con taladro de 8mm (no incluida), hacer los agujeros en la pared y encaje los casquillos plásticos.  
With a drill with 8mm drill bit (not supplied), drill the holes in the wall and fit plastic bushings.



B20 - 8x

04/08

## 3 FIXAÇÃO DAS TRAVESSAS '02' NA PAREDE.

Fijación de los travesaños '02' en la pared.  
Fixing the '02' sleepers on the wall.

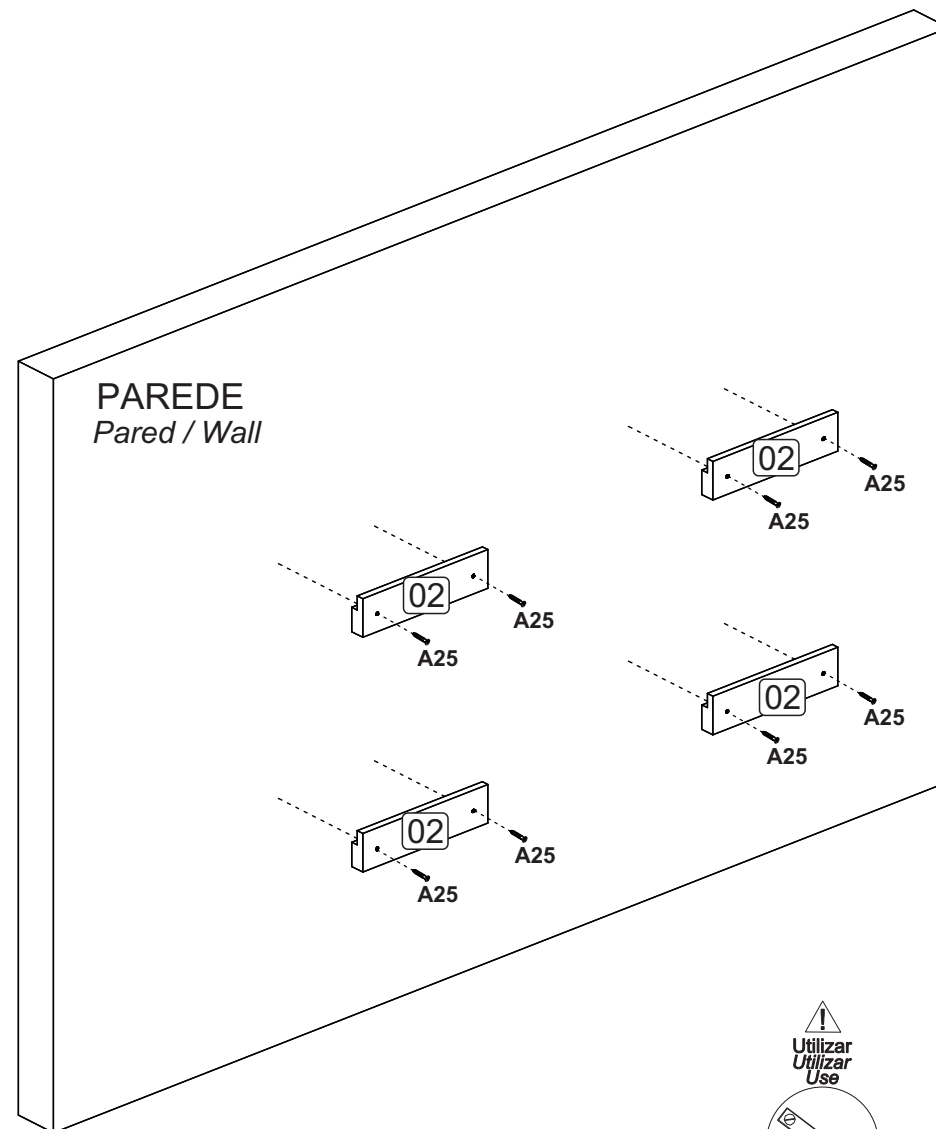

A25 - 8x

Utilizar Utilizar Use  
NÍVEL (NÃO FORNECIDO)  
Nivel (no proporcionado).  
Level (Not provided).

05/08