

## Capacidade de Carga - Load Capacity - Capacidad de carga

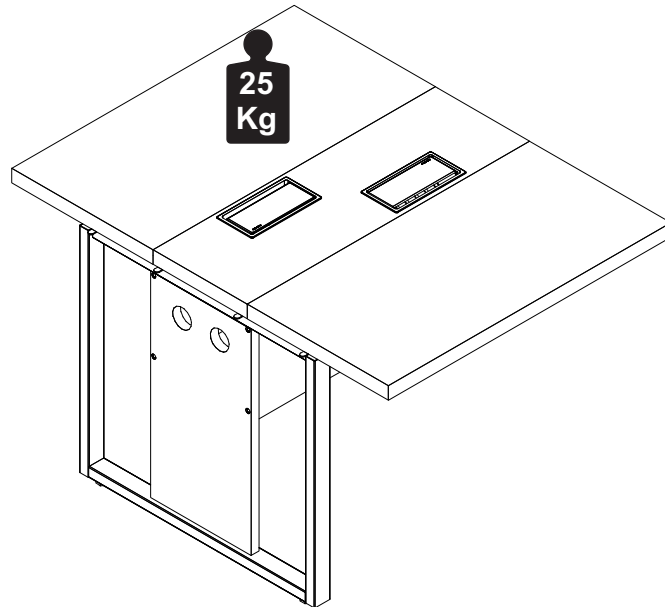

### Manutenção e Limpeza

Vidros: pano levemente umedecido com álcool, seguido de pano seco.  
Madeiras: pano levemente umedecido com água, seguido de pano seco.  
\*Nunca utilizar produtos químicos ou abrasivos.

### Maintenance and Cleaning

Glasses: cloth lightly moistened with alcohol, followed by dry cloth.  
Woods: cloth slightly moistened with water, followed by cloth seo.  
\*Never use chemicals or abrasives.

### Mantenimiento y Limpieza

Vidrios: legeramente humedecido con alcohol, seguido de un paño seco.  
Madera: ligeramente humedecido con agua, seguido de un paño seco.  
\*No utilice nunca productos quimicos o abrasivos.

08/08

## INSTRUÇÕES DE MONTAGEM ASSEMBLY INSTRUCTIONS INSTRUCCIONES DE MONTAJE

### PLATAFORMA DUPLA ACOPLAR PÉ QUADRO PIE DE MARCO DE FIJACIÓN DE PLATAFORMA DOBLE DOUBLE PLATFORM ATTACH FRAME FOOT

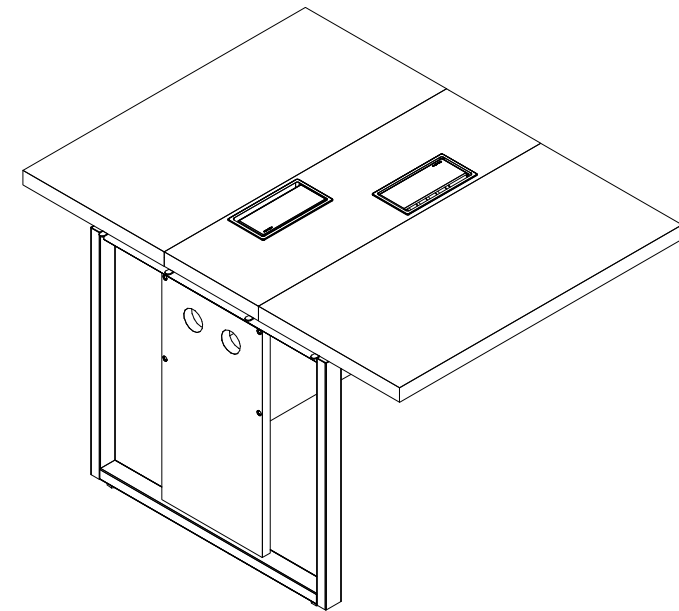

1 P.



8mm



35min

REF. #SAT9018-1218-1318-1518



MOBILIÁRIO

PARA ESCRITÓRIO

GEBB Work Ind. de Móveis Ltda.

Rua Felix Roman, 190

São Valentin

95709-170 - Bento Gonçalves - RS - Brasil

Fone: (0XX54) 3454-1105 - (0XX54) 3453-1407

Phone: (0XX54) 3454-1105 - (0XX54) 3453-1407

E-mail: [pedidos@gebbwork.com.br](mailto:pedidos@gebbwork.com.br)

[www.gebbwork.com.br](http://www.gebbwork.com.br)

WhatsApp: +55 54 99177-8324

REV.: 02 - 19/05/2022

01/08

## LISTA DE PEÇAS

- 01 - Tampo
- 02 - Painel Central
- 03 - Quadro metalico
- 04 - Painel Frontal
- 05 - Régua
- 06 - Travessa Inferior

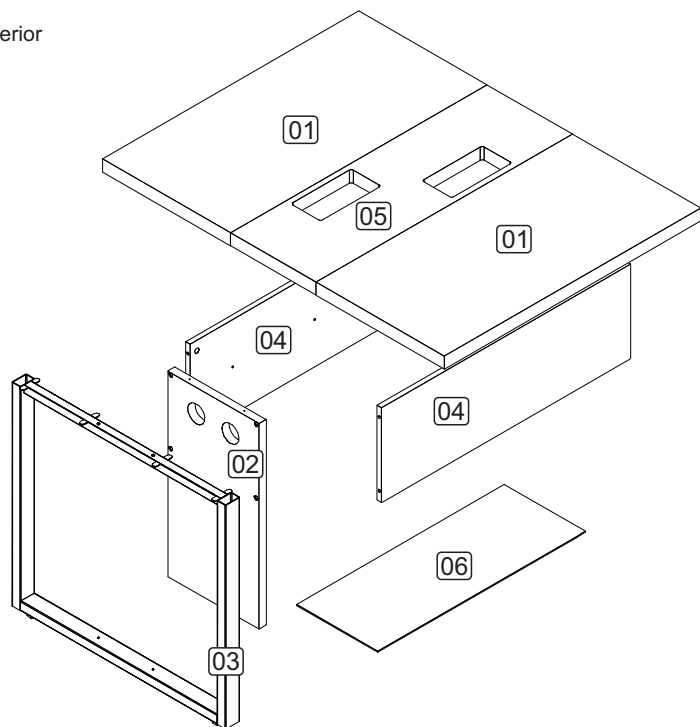

## LISTA DE PIEZAS

- 01 - Tapa
- 02 - Panel Central
- 03 - Estructura metálica
- 04 - Panel Delantero
- 05 - Travesa
- 06 - Travesa Inferior

## PARTS IDENTIFICATION

- 01 - Top
- 02 - Center Panel
- 03 - Metal frame
- 04 - Front Panel
- 05 - Traverse
- 06 - Lower Traverse

6

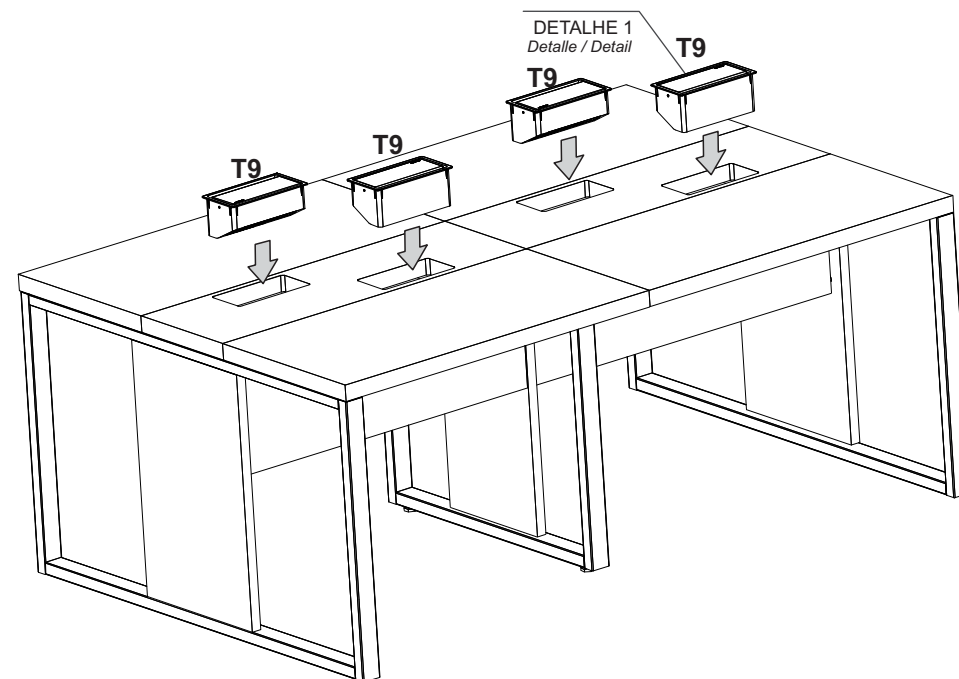

Detalle / Detail  
DETALHE 1

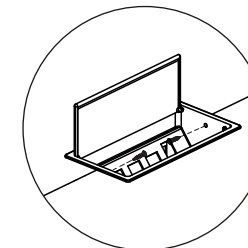

Ver manual me montagem da caixa.  
Consulte el manual de montaje de la caja.  
See box assembly manual.



T9 - 2x

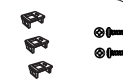

T14 - 2x

4

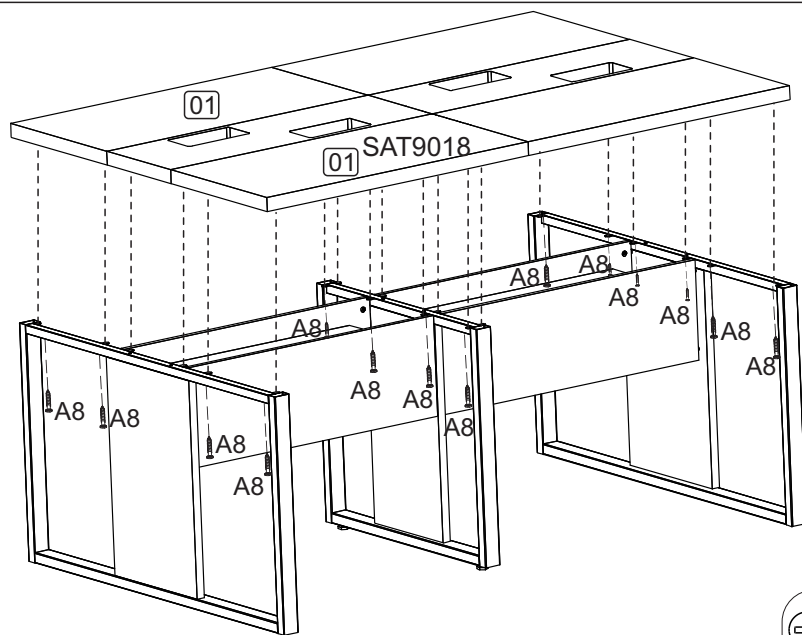

A8 - 6x

5

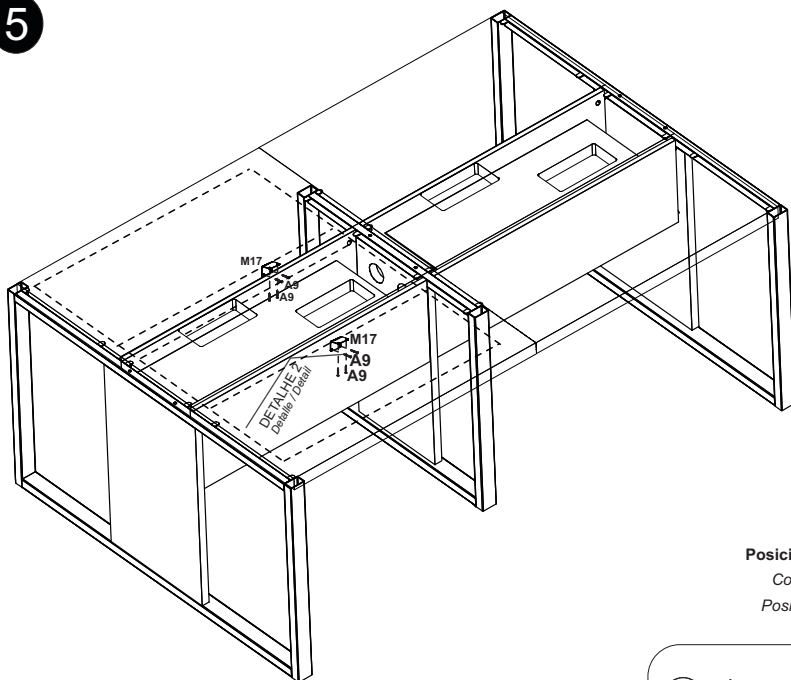

Detalle / Detail  
DETALHE 2

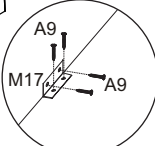

Posicione a cantoneira encostada na quina das peças.  
Coloque la esquina contra la esquina de las piezas.  
Position the corner against the corner of the pieces.



A9 - 8x



M17 - 2x

06/08

## ACESSÓRIOS ACCESSORIES ACCESORIOS

A8 - PARAF. 4,0x14 CP  
**18x**

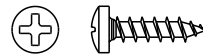

A29 - PARAF. MINIFIX  
M6x33m **8x**

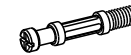

A35 - TAMBOR  
MINIFIX **8x**



A36 - BUCHA M6x13  
**8x**



B1 - SUPORTE PRAT.  
METÁLICO **8x**



L5 - BUCHA PLÁSTICA  
P/SAPATA 5/16 **2x**



F1 - TAPA FURO Ø18  
**4x**



L2 - SAPATA PLAST.  
SEXT. **2x**



T9 - CAIXA DE TOMADA  
PLÁSTICA **2x**

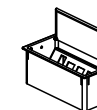

M4 - CHAPA P/CONEXÃO  
04 FUROS **8x**

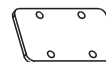

M17 - CANTONEIRA L  
4 FUROS 34x34MM **2x**

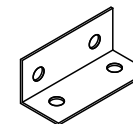

A15 - PARAF. 4,0x40 CP  
**4x**



T10 - BASE PASSA CABO  
25x60 PTO. **2x**



T14 - KIT P/CAIXA DE  
TOMADA **1x**

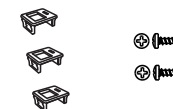

A9 - PARAF. 4,0x16 CC  
**36x**



03/08

# 1 PRÉ-MONTAGEM

Preasamblea  
Pre-assembly

MINIFIX AMBOS OS LADOS

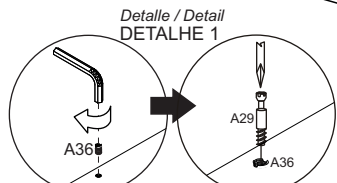
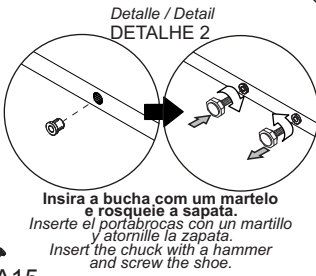
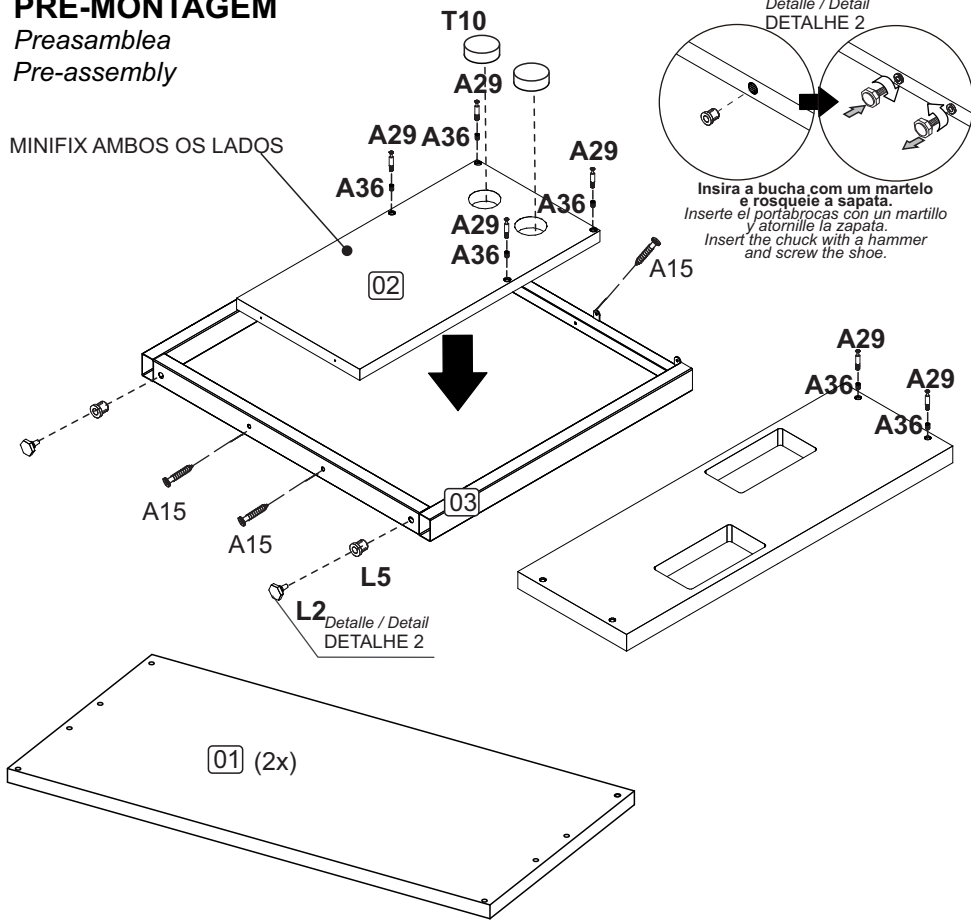

Com uma chave allen insira a bucha na peça, após, rosqueie o parafuso.  
Con una llave Allen, inserte el mandril en la pieza y luego, atornille el tornillo.  
Using an Allen key, insert the chuck into the part, then screw the screw.

04/08

- A15 - 4x
- T10 - 2x
- A36 - 12x
- B1 - 8x
- L2 - 2x
- L5 - 2x
- A29 - 12x

# 2 MONTAGEM

Armado  
Assembly

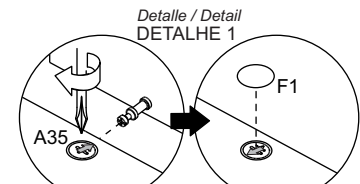
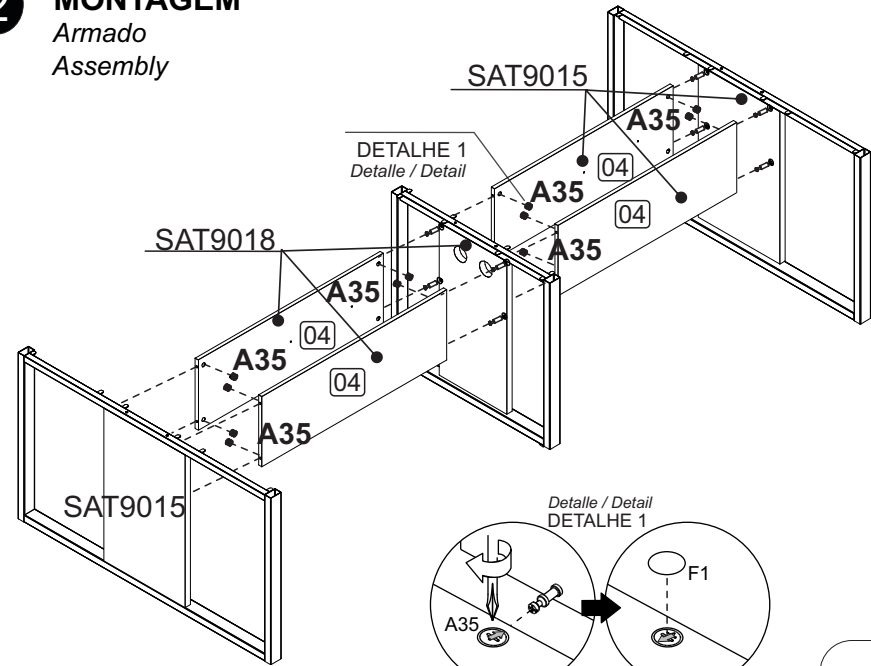

Depois de encaixar as peças coloque o tambor com a sua seta voltada para o parafuso. Para apertar Gire no sentido horário.  
Después de colocar las piezas, coloque el tambor con su flecha hacia el tornillo. Para apretar, gire en sentido horario.  
After fitting the parts, place the drum with its arrow facing the screw. To tighten, turn clockwise.

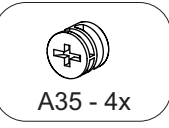

# 3

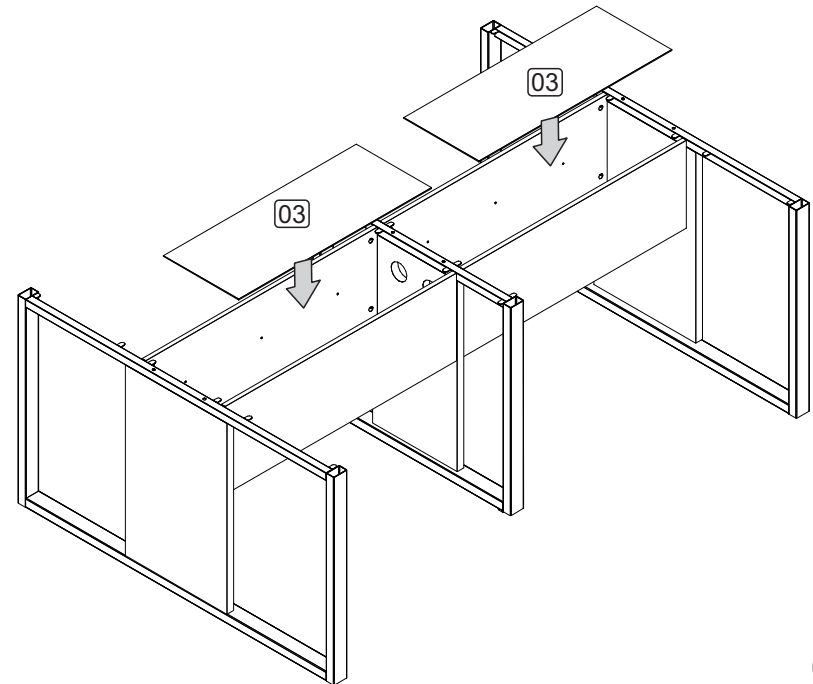

05/08