

## Capacidade de Carga - Load Capacity - Capacidad de carga

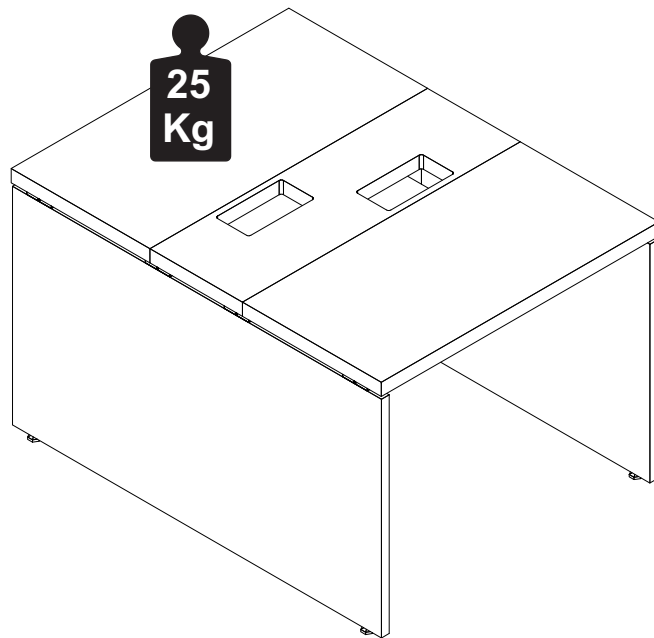

### Manutenção e Limpeza

Vidros: pano levemente umedecido com álcool, seguido de pano seco.  
Madeiras: pano levemente umedecido com água, seguido de pano seco.  
\*Nunca utilizar produtos químicos ou abrasivos.

### Maintenance and Cleaning

Glasses: cloth lightly moistened with alcohol, followed by dry cloth.  
Woods: cloth slightly moistened with water, followed by cloth seo.  
\*Never use chemicals or abrasives.

### Mantenimiento y Limpieza

Vidrios: legeramente humedecido con alcohol, seguido de un paño seco.  
Madera: ligeramente humedecido con agua, seguido de un paño seco.  
\*No utilice nunca productos quimicos o abrasivos.

## INSTRUÇÕES DE MONTAGEM ASSEMBLY INSTRUCTIONS INSTRUCCIONES DE MONTAJE

### PLATAFORMA DUPLA PLATAFORMA DOBLE DOUBLE PLATFORM

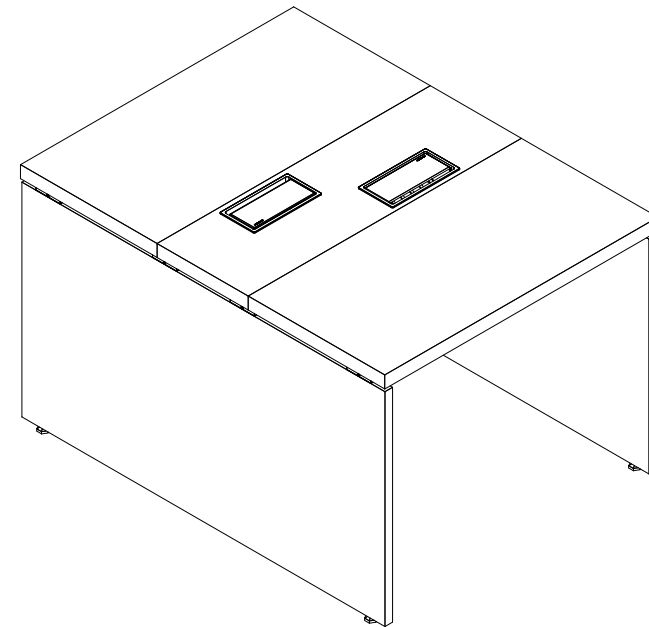

1 P.



8mm



35mm

REF. #SAT9019-1219-1319-1519



MOBILIÁRIO

PARA ESCRITÓRIO

GEBB Work Ind. de Móveis Ltda.

Rua Felix Roman, 190

São Valentin

95709-170 - Bento Gonçalves - RS - Brasil

Fone: (0XX54) 3454-1105 - (0XX54) 3453-1407

Phone: (0XX54) 3454-1105 - (0XX54) 3453-1407

E-mail: [pedidos@gebbwork.com.br](mailto:pedidos@gebbwork.com.br)

[www.gebbwork.com.br](http://www.gebbwork.com.br)

WhatsApp: +55 54 99177-8324

## LISTA DE PEÇAS

- 01 - Tampo
- 02 - Painel Lateral Direito
- 03 - Painel Lateral Esquerdo
- 04 - Painel Frontal
- 05 - Régua
- 06 - Travessa Inferior

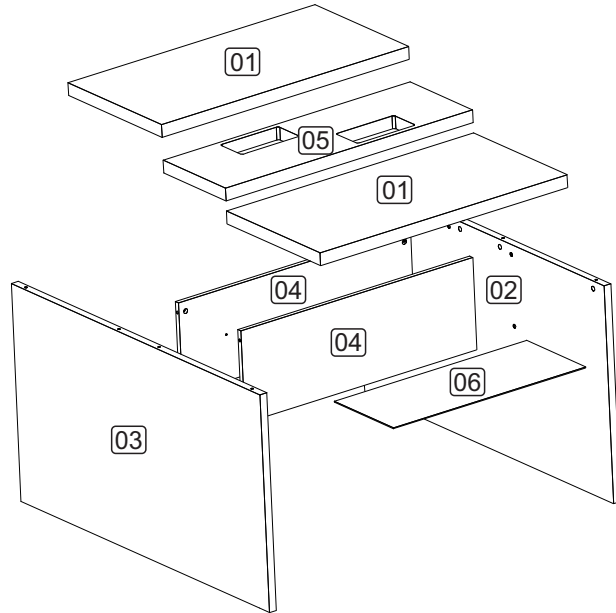

## LISTA DE PIEZAS

- 01 - Tapa
- 02 - Panel Lateral Derecho
- 03 - Panel Lateral Izquierdo
- 04 - Panel Delantero
- 05 - Travesa
- 06 - Travesa Inferior

## PARTS IDENTIFICATION

- 01 - Top
- 02 - Right Side Panel
- 03 - Left Side Panel
- 04 - Front Panel
- 05 - Traverse
- 06 - Lower Traverse

5

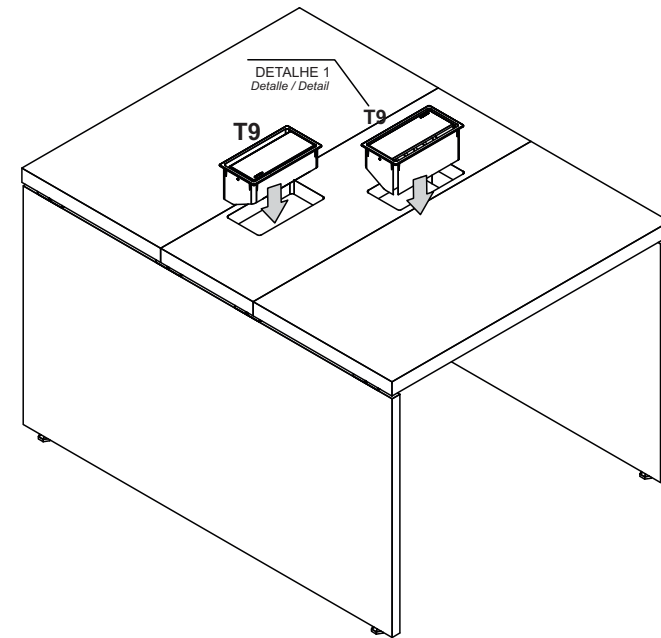

*Detalle / Detail*  
DETALHE 1

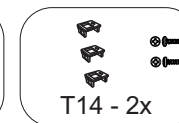
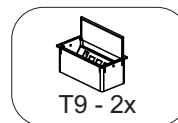
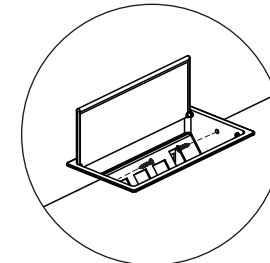

**Ver manual de montagem da caixa.**  
*Consulte el manual de montaje de la caja.*  
*See box assembly manual.*

Detalle / Detail  
DETALHE 3

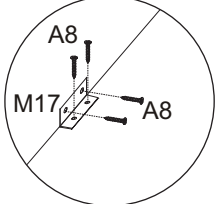

**Posicione a cantoneira encostada na quina das peças.**  
 Coloque la ángulo contra la esquina de las piezas.  
 Position the corner against the corner of the pieces.

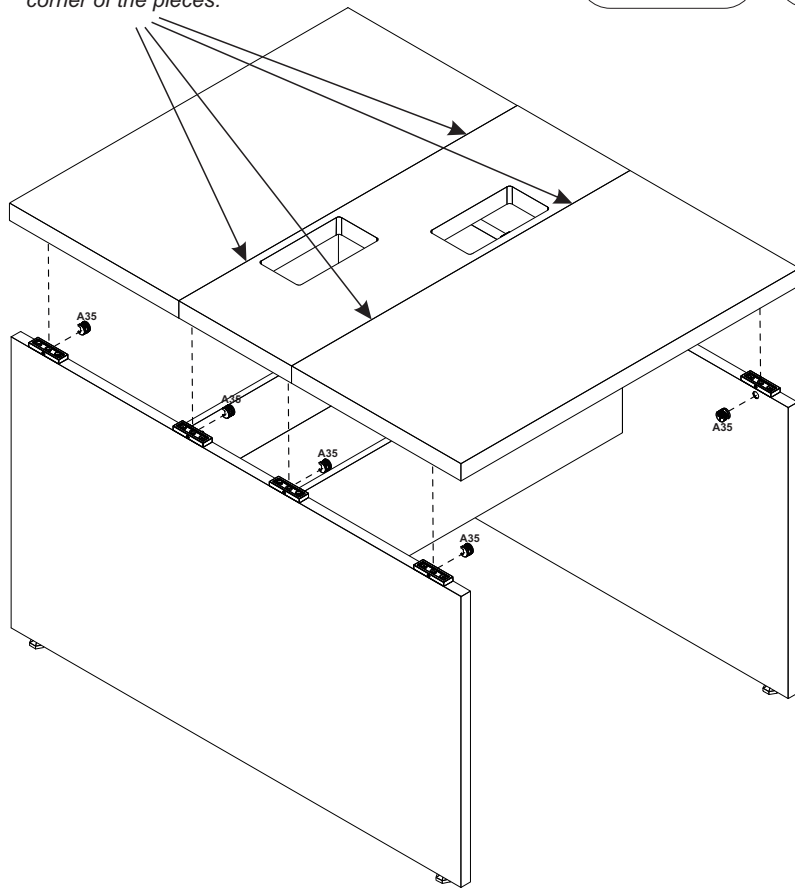

Detalle / Detail  
DETALHE 1

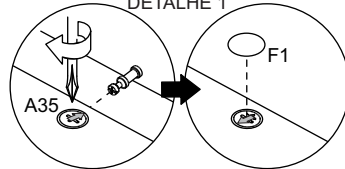

Depois de encaixar as peças coloque o tambor com a sua seta voltada para o parafuso. Para apertar Gire no sentido horário.  
 Después de colocar las piezas, coloque el tambor con su flecha hacia el tornillo. Para apretar, gire en sentido horario.  
 After fitting the parts, place the drum with its arrow facing the screw. To tighten, turn clockwise.

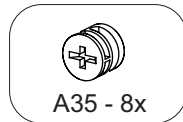

A35 - 8x

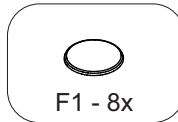

F1 - 8x

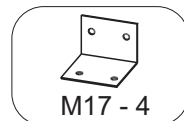

M17 - 4

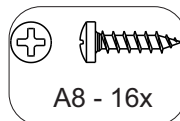

A8 - 16x

# ACESSÓRIOS ACCESSORIES ACCESORIOS

A8 - PARAF. 4,0x14 CP  
**24x**



A29 - PARAF. MINIFIX  
M6x33m **16x**

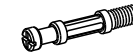

A35 - TAMBOR  
MINIFIX **16x**



A36 - BUCHA M6x13  
**16x**



B1 - SUPORTE PRAT.  
METÁLICO **8x**



L5 - BUCHA PLÁSTICA  
P/SAPATA 5/16 **4x**



F1 - TAPA FURO Ø18  
**8x**



L2 - SAPATA PLAST.  
SEXT. **4x**



T14 - KIT P/CAIXA DE  
TOMADA **1x**

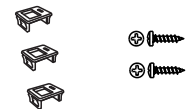

T9 - CAIXA DE TOMADA  
PLÁSTICA **2x**

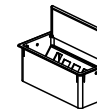

M17 - CANTONEIRA L  
4 FUROS 46x46MM **4x**



B27 -SUPORTE 80x25X10  
**8x**

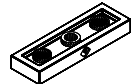

A12 - PARAF. 4,0x30 CC  
**16x**



M9 - CANTONEIRA L  
2 FUROS ZAMAK **4x**



# 1 PRÉ-MONTAGEM

Preasamblea  
Pre-assembly

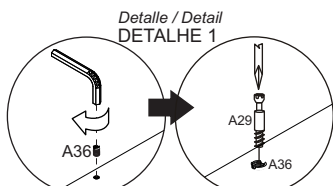
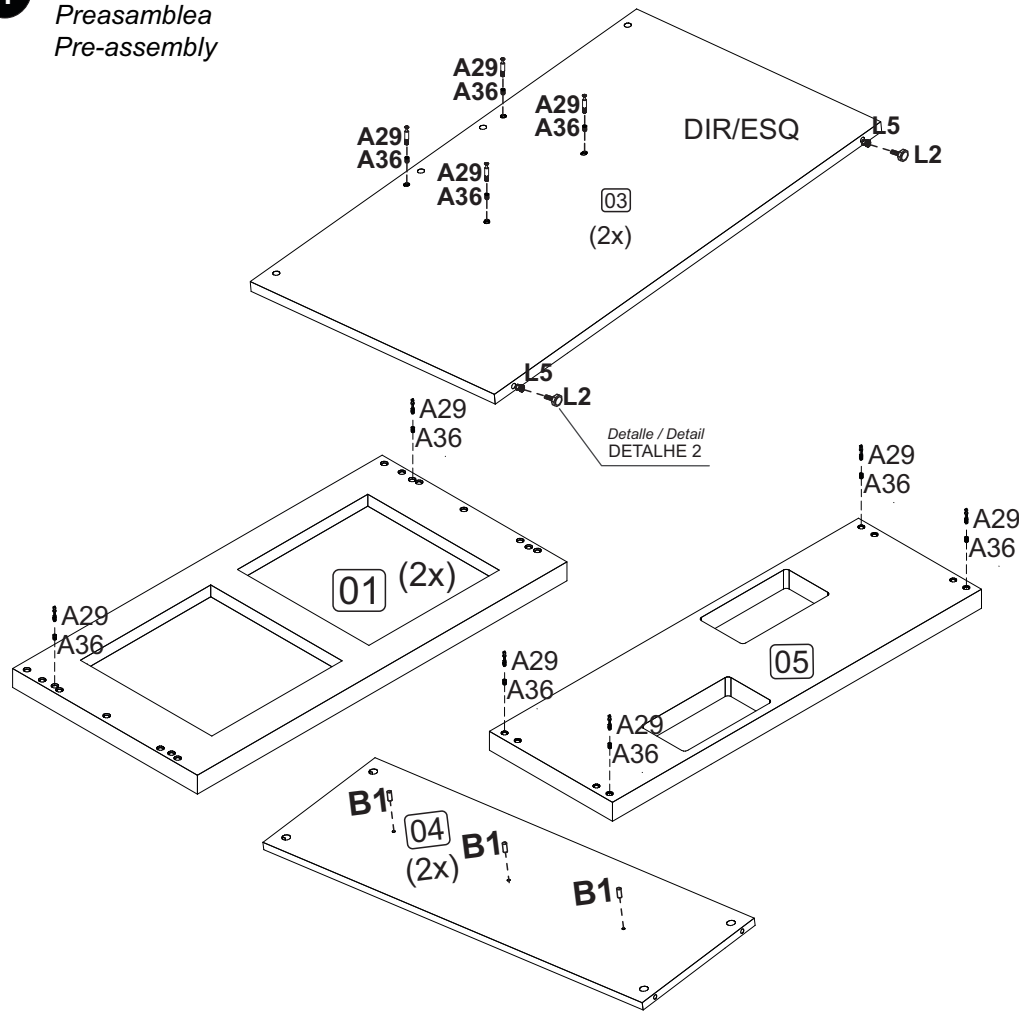

Com uma chave allen insira a bucha na peça, após, rosqueie o parafuso. Con una llave Allen, inserte el mandril en la pieza y luego atornille el tornillo. Using an Allen key, insert the chuck into the part, then screw the screw.

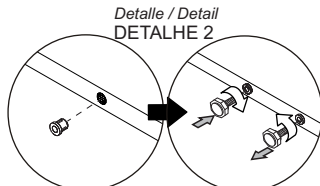

Insira a bucha com um martelo e rosqueie a sapata. Inserte el portabrocas con un martillo y atornille la zapata. Insert the chuck with a hammer and screw the shoe.



B1 - 8x



L2 - 4x



L5 - 4x

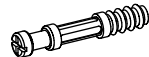

A29 - 16x

# 2 MONTAGEM

Armado  
Assembly

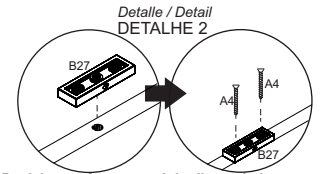
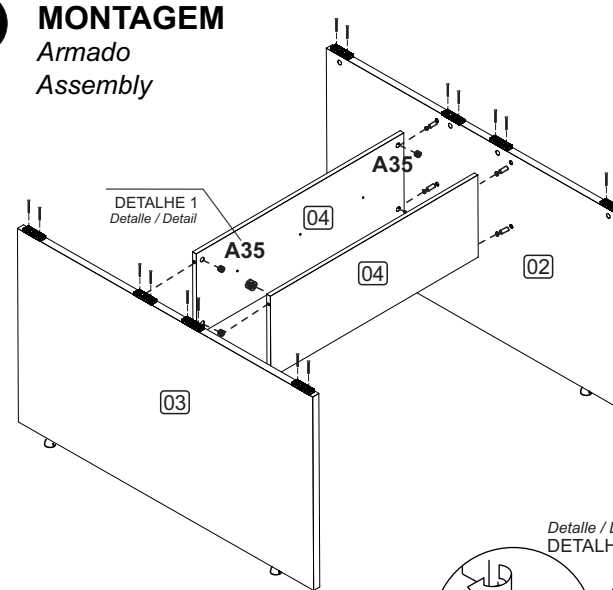

Posicione o furo central do distanciador com o furo da peça, após parafuse nos furos laterais. Coloque el orificio central del espaciador con el orificio en la pieza, después de atornillar los orificios laterales. Position the central hole of the spacer with the hole in the part, after screwing in the side holes.

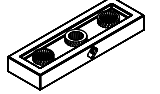

B27 - 8x



A12 - 16x

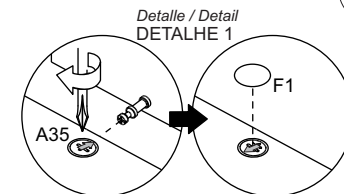

Depois de encaixar as peças coloque o tambor com a sua seta voltada para o parafuso. Para apertar Gire no sentido horário. Después de colocar las piezas, coloque el tambor con su flecha hacia el tornillo. Para apretar, gire en sentido horario. After fitting the parts, place the drum with its arrow facing the screw. To tighten, turn clockwise.



A35 - 8x

# 3

