

## Capacidade de Carga - Load Capacity - Capacidad de carga

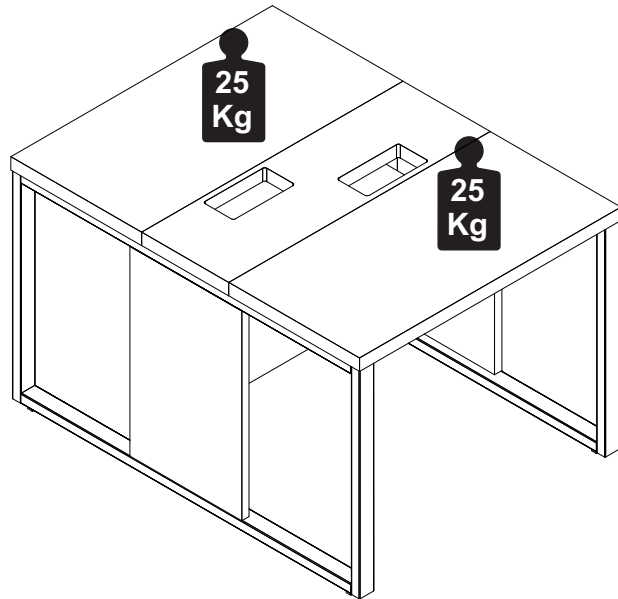

### Manutenção e Limpeza

Vidros: pano levemente umedecido com álcool, seguido de pano seco.  
Madeiras: pano levemente umedecido com água, seguido de pano seco.  
\*Nunca utilizar produtos químicos ou abrasivos.

### Maintenance and Cleaning

Glasses: cloth lightly moistened with alcohol, followed by dry cloth.  
Woods: cloth slightly moistened with water, followed by cloth seco.  
\*Never use chemicals or abrasives.

### Mantenimiento y Limpieza

Vidrios: legeramente humedecido con alcohol, seguido de un paño seco.  
Madera: ligeramente humedecido con agua, seguido de un paño seco.  
\*No utilice nunca productos quimicos o abrasivos.

## INSTRUÇÕES DE MONTAGEM ASSEMBLY INSTRUCTIONS INSTRUCCIONES DE MONTAJE

### PLATAFORMA DUPLA TABLE DOUBLE TABLA DOBLE

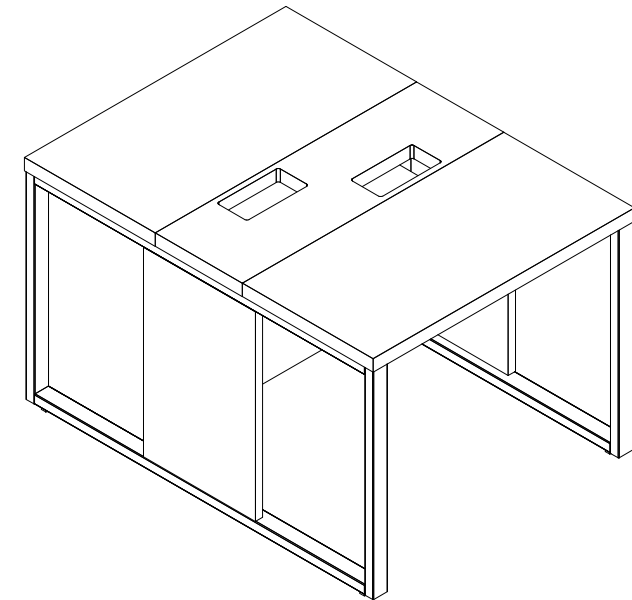

2 P.



8mm



45mim

REF. #SAT9015-1215-1315-1515



MOBILIÁRIO  
PARA ESCRITÓRIO

GEBB Work Ind. de Móveis Ltda.  
Rua Felix Roman, 190  
São Valentin

95709-170 - Bento Gonçalves - RS - Brasil  
Fone: (0XX54) 3454-1105 - (0XX54) 3453-1407  
Phone: (0XX54) 3454-1105 - (0XX54) 3453-1407

E-mail: [pedidos@gebbwork.com.br](mailto:pedidos@gebbwork.com.br)

[www.gebbwork.com.br](http://www.gebbwork.com.br)

WhatsApp: +55 54 99177-8324

## LISTA DE PEÇAS

- 01 - Tampo
- 02 - Pé Lateral Quadro
- 03 - Régua
- 04 - Painel Frontal
- 05 - Aplique Lateral
- 06 - Travessa Inferior

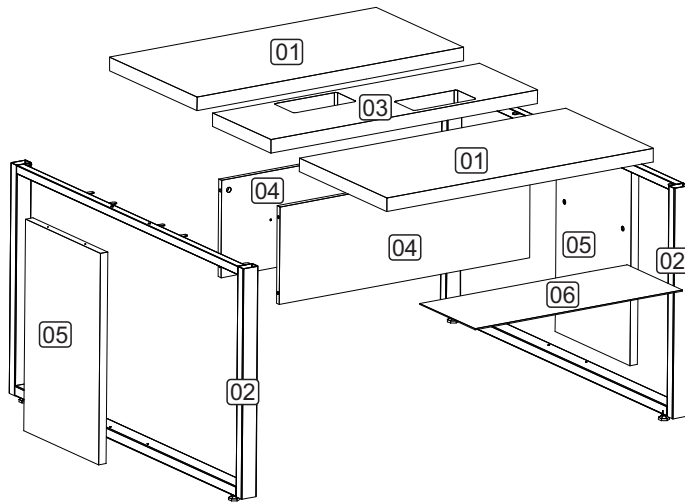

## LISTA DE PIEZAS

- 01 - Tapa
- 02 - Pata Lateral
- 03 - Traviesa
- 04 - Panel Delantero
- 05 - Cerramiento Lateral
- 06 - Traviesa Inferior

## PARTS IDENTIFICATION

- 01 - Top
- 02 - Side Panel
- 03 - Traverse
- 04 - Front Panel
- 05 - Side Closure
- 06 - Lower Traverse

## GABARITO DE POSIÇÃO

Plantilla de posición  
Position template

Posicione o Tampo sobre a estrutura metálica conforme as medidas a baixo.  
Position the worktop over the metal structure according to the measurements below.  
Coloque la encimera sobre la estructura metálica según las siguientes medidas.

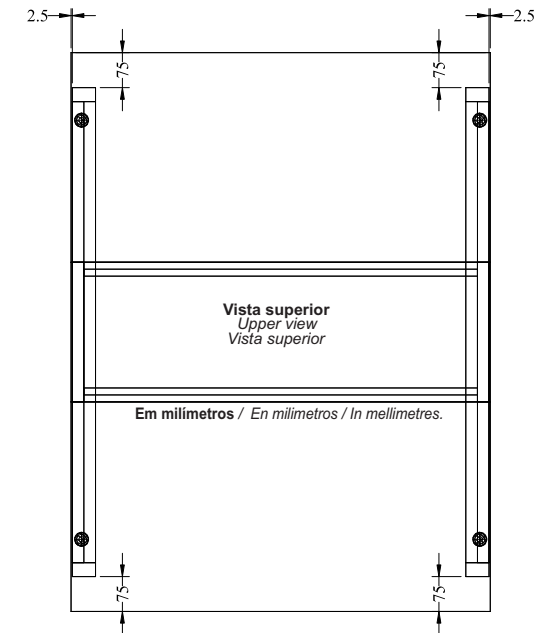

7

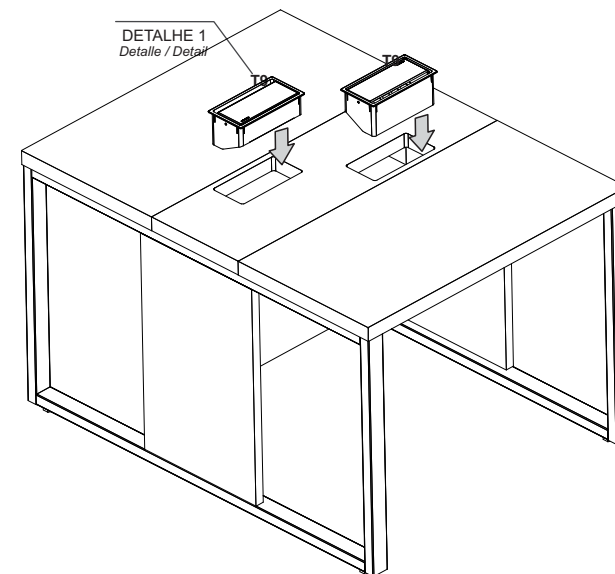

Detalle / Detail  
DETALHE 1

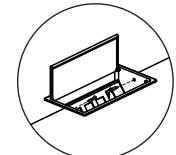

Ver manual de montagem da caixa.  
Consulte el manual de montaje de la caja.  
See box assembly manual.



T9 - 2x



T14 - 2x

**5****Unir tampos 01 aos pés metálicos 02**

Unir tapas 01 a patas metálicas 02

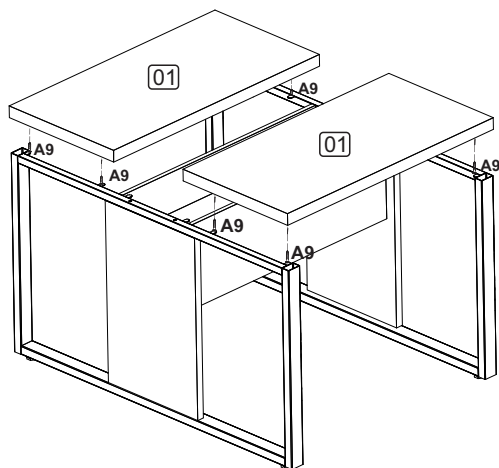

A9 - 8x

**6****Fixar régua para caixa de tomadas em pé metálico.**

Fije la regla a la caja del zócalo en pie metálico.

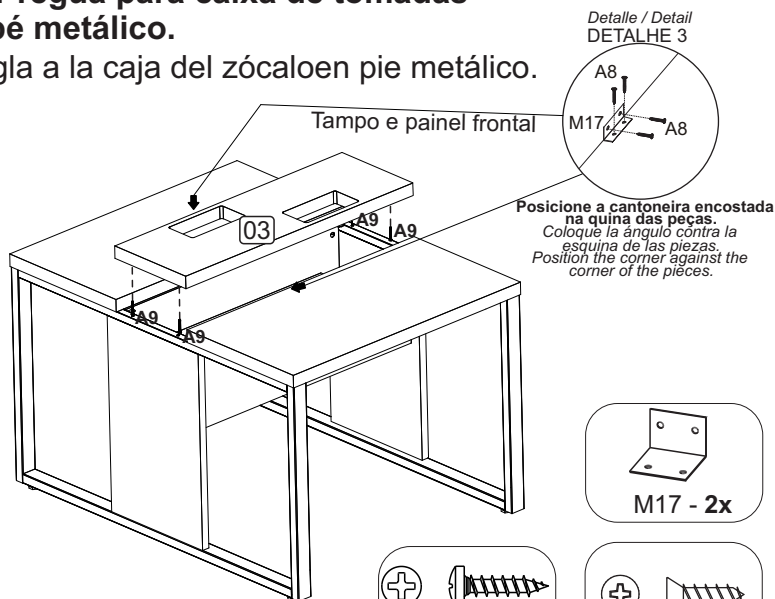
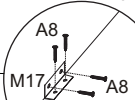
Detalle / Detail  
DETALHE 3

Posicione a cantoneira encostada na quina das peças.  
Coloque la ángulo contra la esquina de las piezas.  
Position the corner against the corner of the pieces.



M17 - 2x



A8 - 8x



A9 - 4x

**ACESSÓRIOS** ACCESSORIES ACCESORIOS

A15 - PARAF. 4,0x40 CP

8x



A9 - PARAF. 4,0x16 CC

12x



A8 - PARAF. 4,0x14 CP

16x



A36 - BUCHA M6x13

8x



A29 - PARAF. MINIFIX

M6x33m 8x

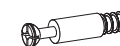

A35 - TAMBOR

MINIFIX 8x

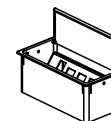
L5 - BUCHA PLÁSTICA  
P/SAPATA 5/16 4xB1 - SUPORTE PRAT.  
METÁLICO 8xL2 - SAPATA PLAST.  
SEXT. 4xT9 - CAIXA DE TOMADA  
PLÁSTICA 2xT14 - KIT P/CAIXA DE  
TOMADA 2xM17 - CANTONEIRA L  
4 FUROS 46x46MM 2x

# 1 PRÉ-MONTAGEM

Preasamblea  
Pre-assembly

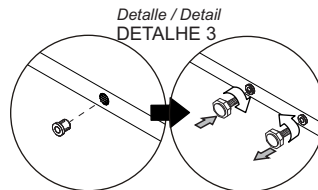
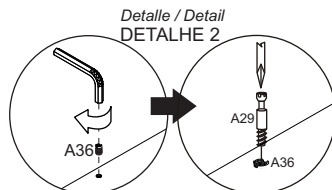
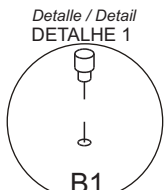
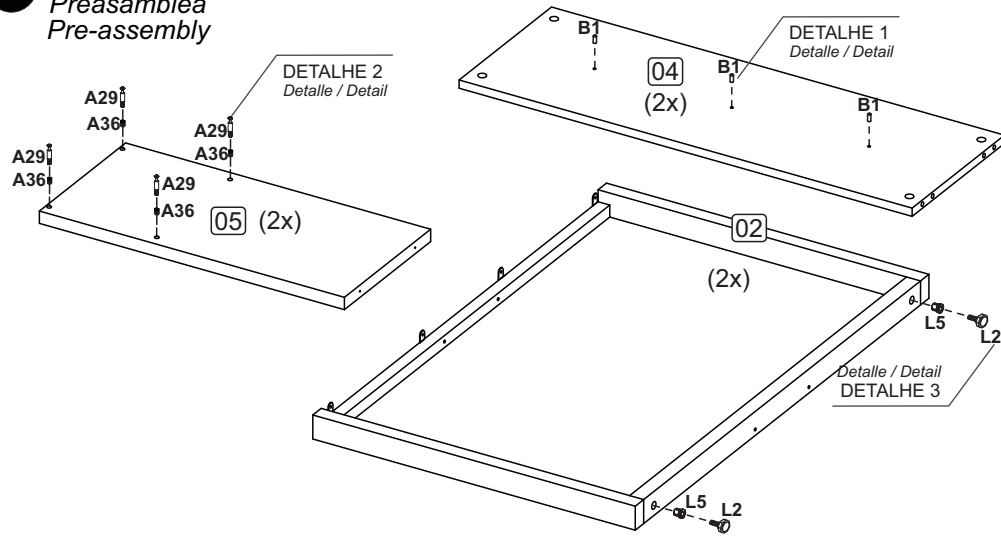

Se necessário utilize um martelo de borracha.  
Si es necesario, utilice un martillo de goma.  
If necessary, use a rubber hammer.

Com uma chave allen insira a bucha na peça, após, rosqueie o parafuso.  
Con una llave Allen, inserte el mandril en la pieza y luego atornille el tornillo.  
Using an Allen key, insert the chuck into the part, then screw the screw.

Insira a bucha com um martelo e rosqueie a sapata.  
Inserte el portabrocas con un martillo y atornille la zapata.  
Insert the chuck with a hammer and screw the shoe.

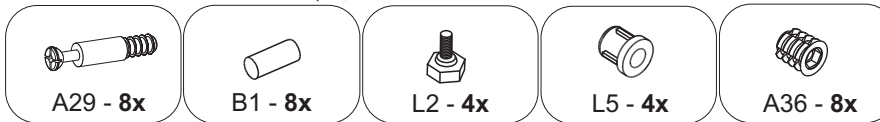

# 2 MONTAGEM

Armado  
Assembly

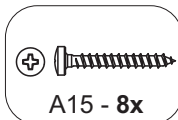
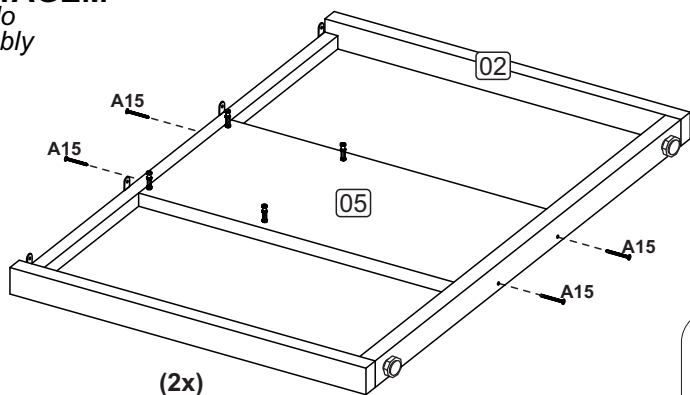

# 3

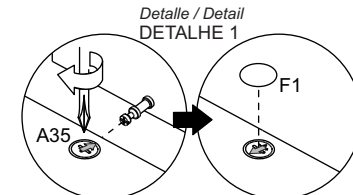
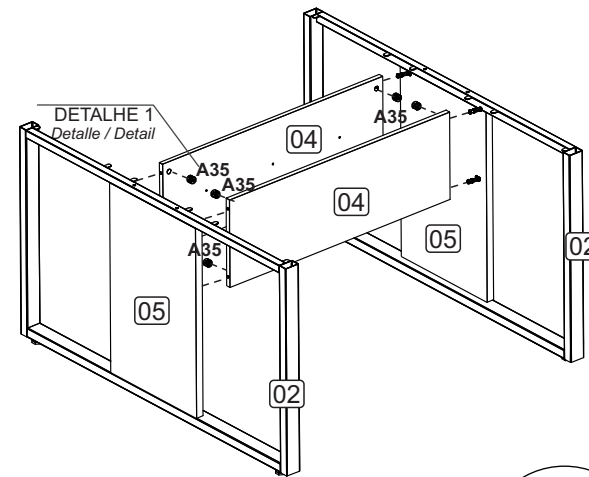

Depois de encaixar as peças coloque o tambor com a seta voltada para o parafuso. Para apertar Gire no sentido horário.  
Después de colocar las piezas, coloque el tambor con su flecha hacia el tornillo. Para apretar, gire en sentido horario.  
After fitting the parts, place the drum with its arrow facing the screw. To tighten, turn clockwise.



# 4

