

Capacidade de Carga - Load Capacity - Capacidad de carga

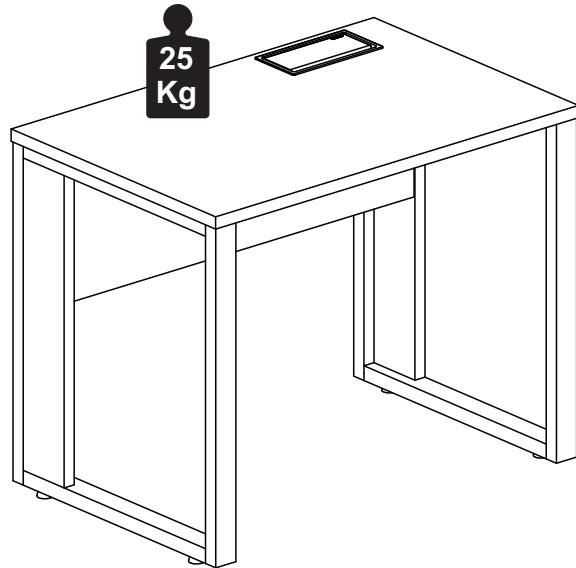

Manutenção e Limpeza

Vidros: pano levemente umedecido com álcool, seguido de pano seco.
Madeiras: pano levemente umedecido com água, seguido de pano seco.
*Nunca utilizar produtos químicos ou abrasivos.

Maintenance and Cleaning

Glasses: cloth lightly moistened with alcohol, followed by dry cloth.
Woods: cloth slightly moistened with water, followed by cloth seo.
*Never use chemicals or abrasives.

Mantenimiento y Limpieza

Vidrios: legeramente humedecido con alcohol, seguido de un paño seco.
Madera: ligeramente humedecido con agua, seguido de un paño seco.
*No utilice nunca productos quimicos o abrasivos.

INSTRUÇÕES DE MONTAGEM ASSEMBLY INSTRUCTIONS INSTRUCCIONES DE MONTAJE

PLATAFORMA SIMPLES PÉ QUADRO MESA SIMPLE PATA METÁLICA SIMPLE TABLE METALLIC FOOT

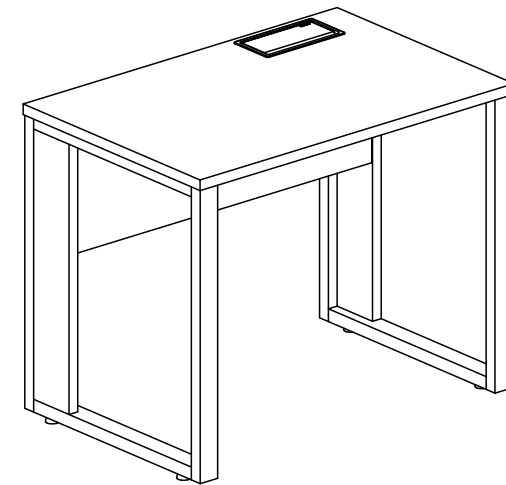

1 P.



8mm



30mim

REF. #VRA5064-5264-5364-5564

REF. #EXP5064-5264-5364-5564

 **Gebbwork**

MOBILIÁRIO
PARA ESCRITÓRIO

GEBB Work Ind. de Móveis Ltda.
Rua Felix Roman, 190
São Valentin

95709-170 - Bento Gonçalves - RS - Brasil
Fone: (0XX54) 3454-1105 - (0XX54) 3453-1407
Phone: (0XX54) 3454-1105 - (0XX54) 3453-1407
E-mail: pedidos@gebbwork.com.br

www.gebbwork.com.br
WhatsApp: +55 54 99177-8324

LISTA DE PEÇAS

- 01 - Tampo
- 02 - Pé Lateral Quadro Direito
- 03 - Pé Lateral Quadro Esquerdo
- 04 - Painel Frontal Maior
- 05 - Aplique Lateral
- 06 - Travessa Inferior
- 07 - Painel Frontal Menor

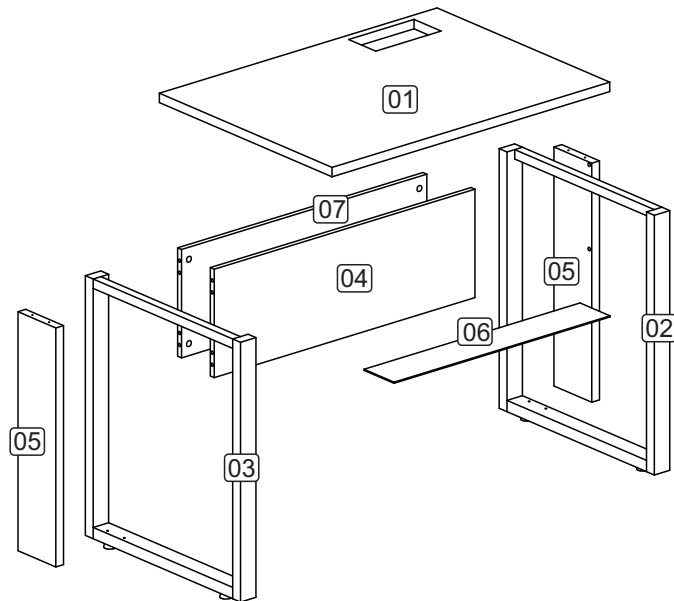

LISTA DE PIEZAS

- 01 - Tapa
- 02 - Pata Lateral Derecho
- 03 - Pata Lateral Izquierdo
- 04 - Panel Delantero Mayor
- 05 - Cerramiento Lateral
- 06 - Traviesa Inferior
- 07 - Panel Delantero Menor

PARTS IDENTIFICATION

- 01 - Top
- 02 - Right Side Panel
- 03 - Left Side Panel
- 04 - Large Front Panel
- 05 - Side closure
- 06 - Lower Traverse
- 07 - Small Front Panel

GABARITO DE POSIÇÃO

Plantilla de posición
Position template

Posicione os Tamos sobre a estrutura metálica conforme as medidas a baixo.
Position the worktop over the metal structure according to the measurements below.
Coloque la encimera sobre la estructura metálica según las siguientes medidas.

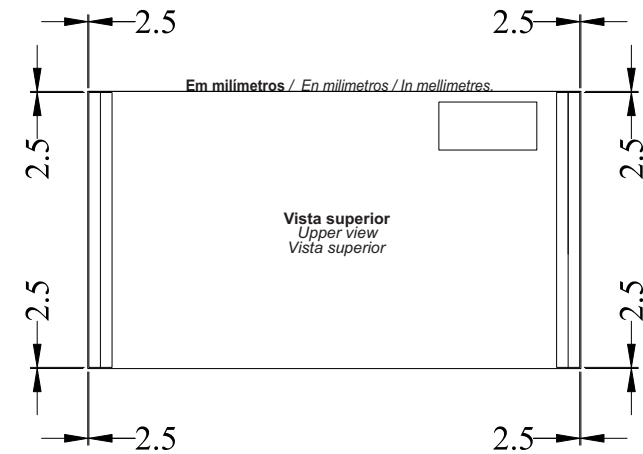

6

DETALHE 1
Detalle / Detail

T9

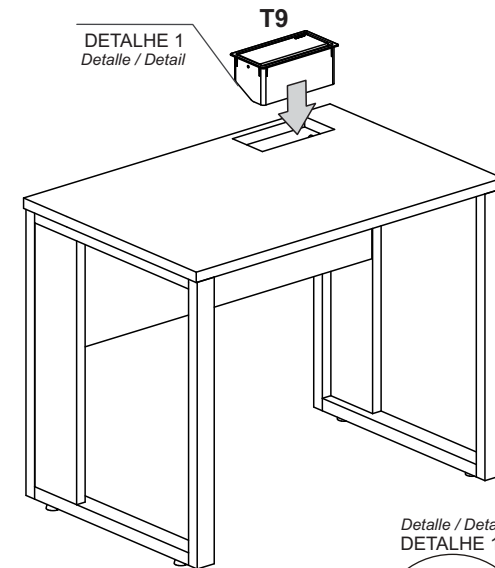

Detalle / Detail
DETALHE 1

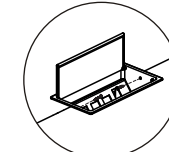

T9 - 1x



T14 - 1x

Ver manual de montagem da caixa.
Consulte el manual de montaje de la caja.
See box assembly manual.

4

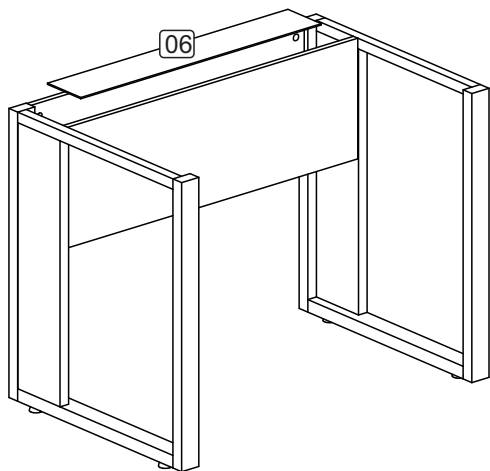

5 Conforme o gabarito de posição (página 7) posicione e parafuse os tampos
 Según la plantilla de posición (página 7), posicionar y atornillar las tapas.
 According to the position template (page 7), position and screw the previously.

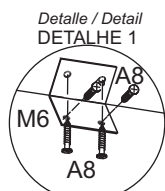
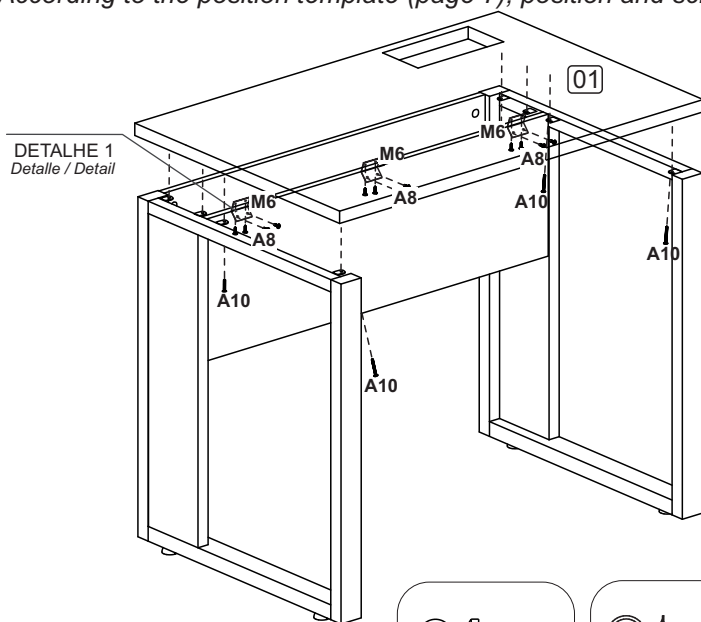

Posicione a cantoneira encostada na quina das peças.
 Coloque la angulo contra la esquina de las piezas.
 Position the corner against the corner of the pieces.



A8 - 12x



A10 - 8x



M6 - 3x

06/08

ACESSÓRIOS ACCESSORIES ACCESORIOS

A8 - PARAF. 4,0x14 CP
12x



A10 - PARAF. 4,0x20 CF
8x



A15 - PARAF. 4,0x40 CP
8x



A29 - PARAF. MINIFIX
M6x33m 8x



A35 - TAMBOR
MINIFIX 8x



A36 - BUCHA M6x13
4x



B1 - SUPORTE PRAT.
METÁLICO 8x



L2 - SAPATA PLAST.
SEXT. 4x



L5 - BUCHA PLÁSTICA
P/SAPATA 5/16 4x



M6 - CANTONEIRA L
4 FUROS 34x34MM 3x



T9 - CAIXA DE TOMADA
PLÁSTICA 1x

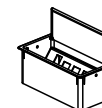

T14 - KIT P/CAIXA DE
TOMADA 1x

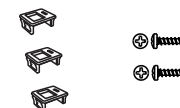

03/08

1 PRÉ-MONTAGEM

Preassembly
Pre-assembly

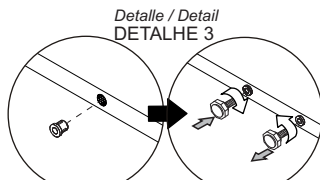
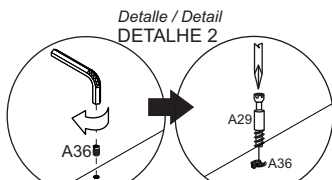
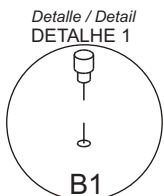
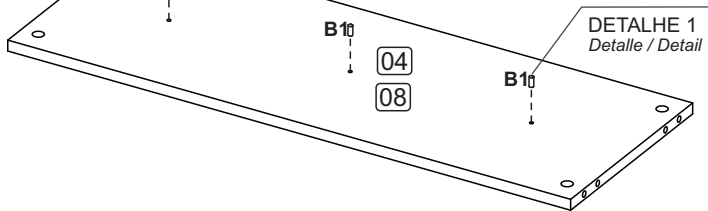
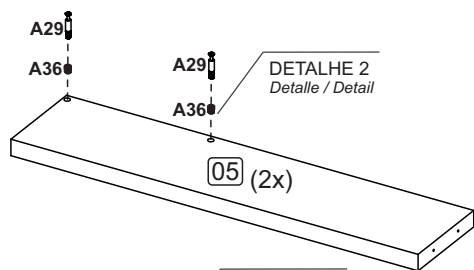
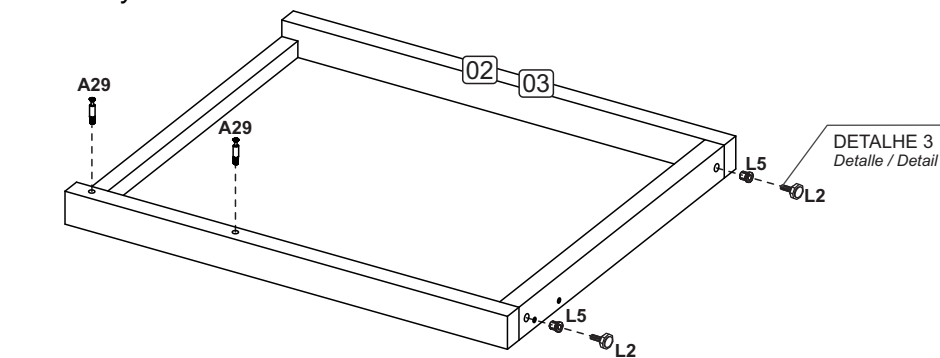

Se necessário utilize um martelo de borracha.
Si es necesario, utilice un martillo de goma.
If necessary, use a rubber hammer.

Com uma chave allen insira a bucha na peça, apos, rosqueie o parafuso.
Con una llave Allen, inserte el mandril en la pieza y luego atornille el tornillo.
Using an Allen key, insert the chuck into the part, then screw the screw.

Insira a bucha com um martelo e rosqueie a sapata.
Inserte el portabrocas con un martillo y atornille la zapata.
Insert the chuck with a hammer and screw the shoe.

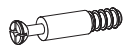

A29 - 8x



B1 - 8x



L2 - 2x



L5 - 2x



A36 - 4x

04/08

2 MONTAGEM

Armado
Assembly

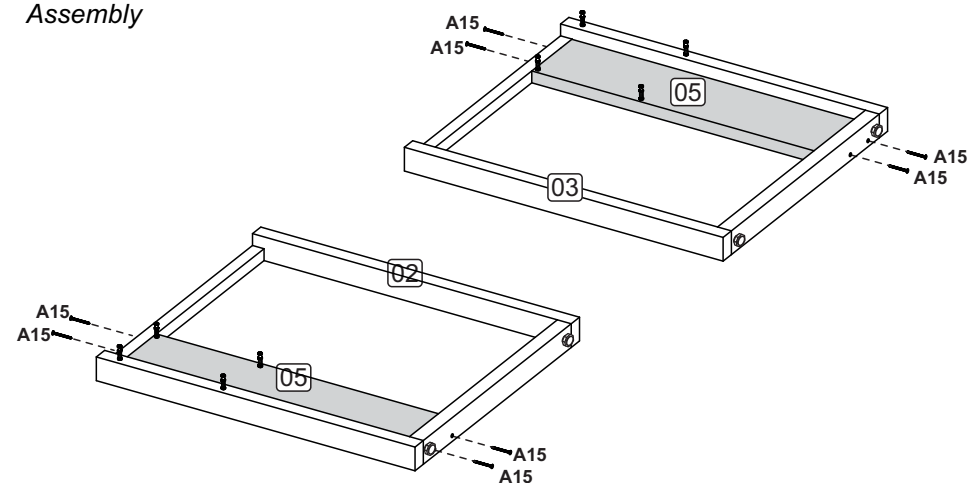

A15 - 8x

3

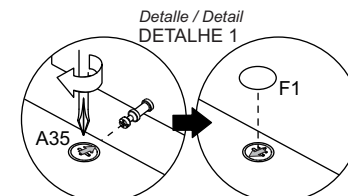
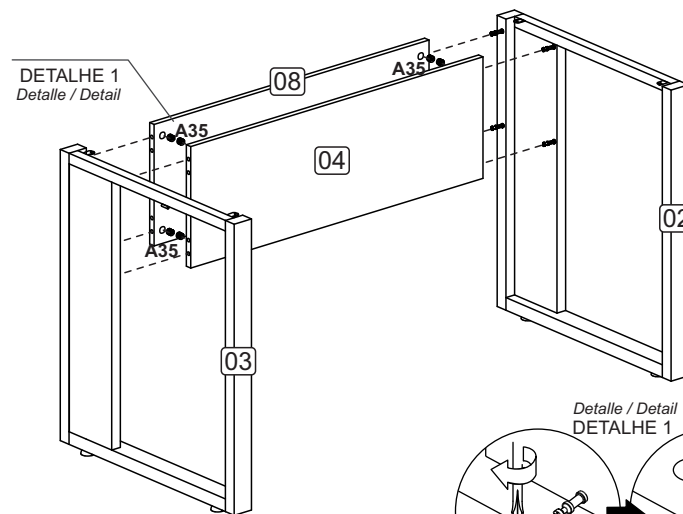

Depois de encaixar as peças coloque o tambor com a sua seta voltada para o parafuso. Para apertar Gire no sentido horário.
Después de colocar las piezas, coloque el tambor con su flecha hacia el tornillo. Para apretar, gire en sentido horario.
To tighten, turn clockwise.



A35 - 8x

05/08