

Capacidade de Carga - Load Capacity - Capacidad de carga

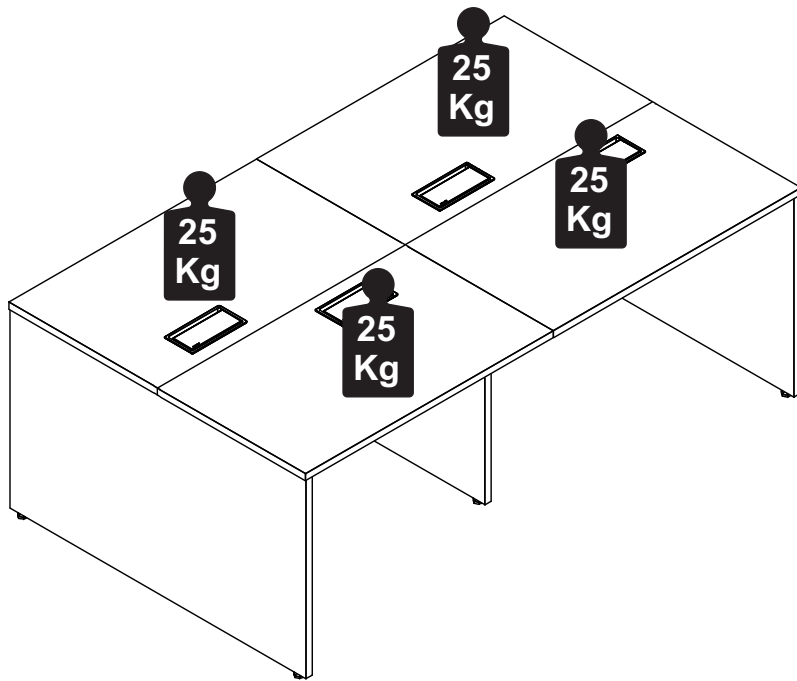

Manutenção e Limpeza

Vidros: pano levemente umedecido com álcool, seguido de pano seco.
Madeiras: pano levemente umedecido com água, seguido de pano seco.
*Nunca utilizar produtos químicos ou abrasivos.

Maintenance and Cleaning

Glasses: cloth lightly moistened with alcohol, followed by dry cloth.
Woods: cloth slightly moistened with water, followed by cloth seo.
*Never use chemicals or abrasives.

Mantenimiento y Limpieza

Vidrios: legeramente humedecido con alcohol, seguido de un paño seco.
Madera: ligeramente humedecido con agua, seguido de un paño seco.
*No utilice nunca productos quimicos o abrasivos.

INSTRUÇÕES DE MONTAGEM ASSEMBLY INSTRUCTIONS INSTRUCCIONES DE MONTAJE

PLATAFORMA ACOPLAR DUPLA TABLE COUPLING DOUBLE TABLA ACOPLAMIENTO DOBLE

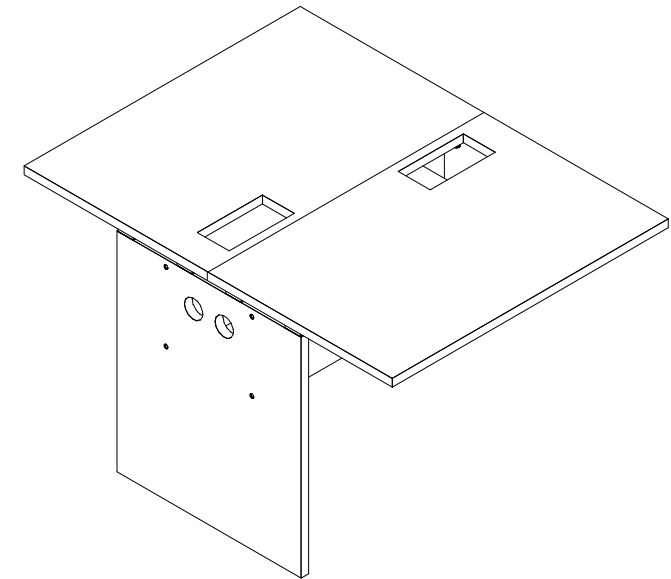

REF. #VRA9017-1217-1317-1517

 **Gebbwork**

MOBILIÁRIO
PARA ESCRITÓRIO

GEBB Work Ind. de Móveis Ltda.
Rua Felix Roman, 190
São Valentin

95709-170 - Bento Gonçalves - RS - Brasil
Fone: (0XX54) 3454-1105 - (0XX54) 3453-1407
Phone: (0XX54) 3454-1105 - (0XX54) 3453-
1407 E-mail: pedidos@gebbwork.com.br
www.gebbwork.com.br
WhatsApp: +55 54 99177-8324



1 P.



8mm



35mm

LISTA DE PEÇAS

- 01 - Painel Central
- 02 - Tampo
- 03 - Painel Frontal
- 04 - Travessa Inferior

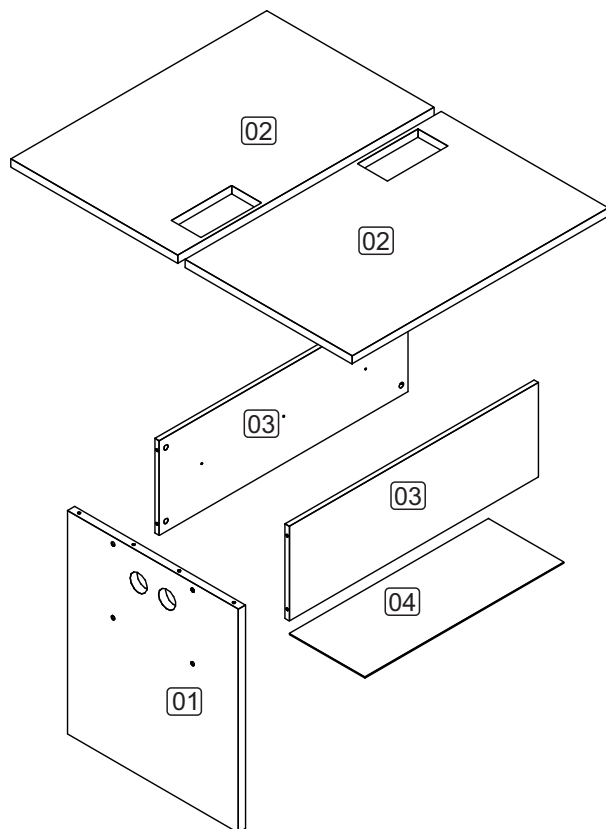

LISTA DE PIEZAS

- 01 - Panel central
- 02 - Tampo
- 03 - Panel frontal
- 04 - Travesaño inferior

PARTS IDENTIFICATION

- 01 - Central Panel
- 02 - Top
- 03 - Front Panel
- 04 - Lower Crossbar

6

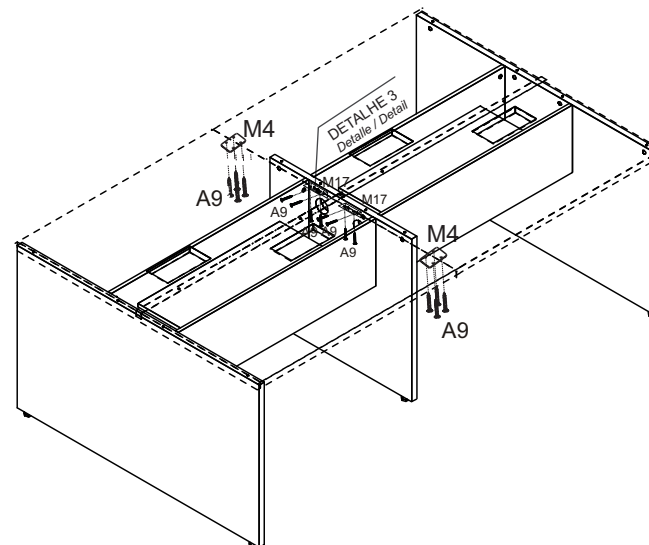

Detalle / Detail
DETALHE 3

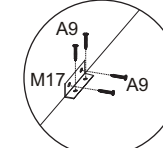

Posicione a cantoneira encostada na quina das peças.
Coloque la angulo contra la esquina de las piezas.
Position the corner against the corner of the pieces.

Detalle / Detail
DETALHE 1

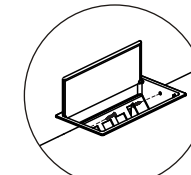

Ver manual de montagem da caixa.
Consulte el manual de montaje de la caja.
See box assembly manual.

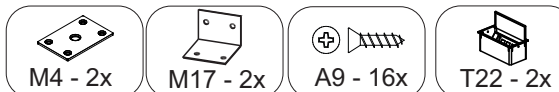

7

POSICIONE AS CHAPAS DE UNIÃO SOBRE AS MARCAÇÕES

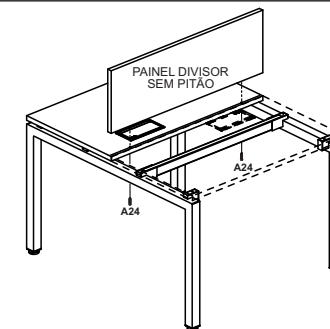
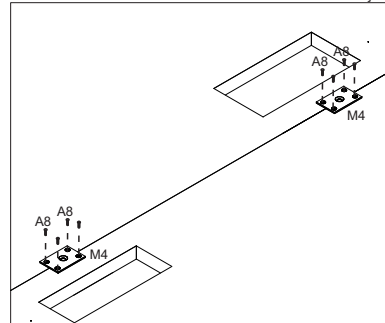

UTILIZE A FURAÇÃO CENTRAL COMO GABARITO
REPASSE A FURAÇÃO COM BROCA Ø8mm

PARA INSTALAÇÃO DE PAINÉIS DIVISORES COM USO DE PITÕES UTILIZE O MANUAL DE MONTAGEM EXCLUSIVO EXCLUSIVO DE CADA TIPO DE PITÃO

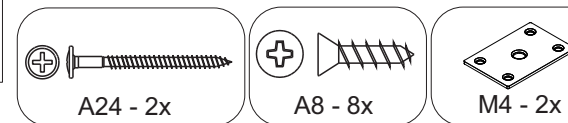
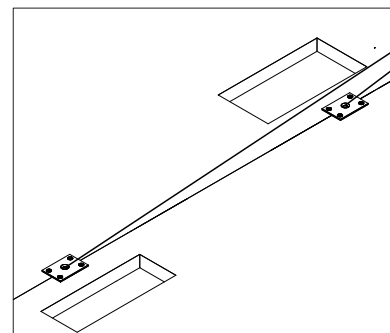

4

Tampo 02 fixado no pé.

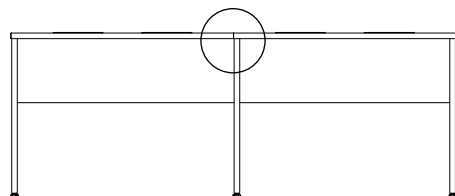
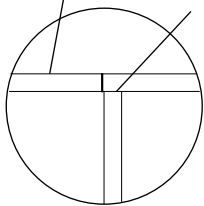

Tampo fixado com chapa de conexão M4.

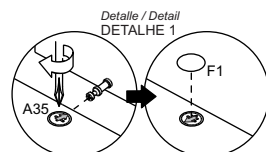
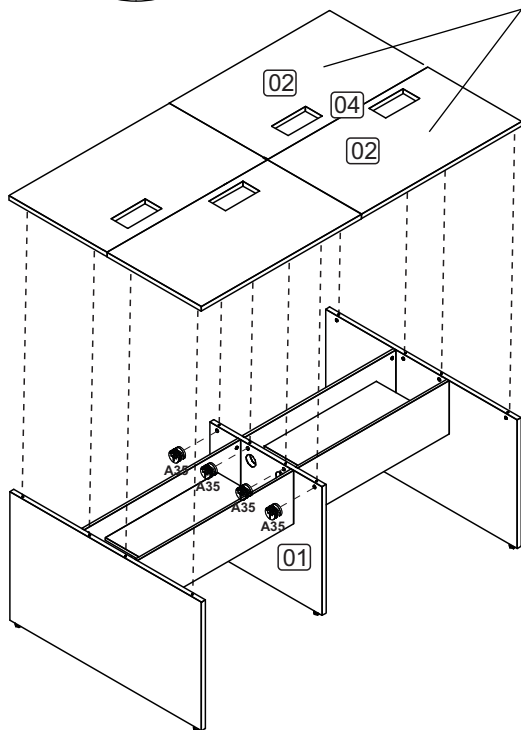

Depois de encaixar as peças coloque o tambor com a sua seta voltada para o parafuso. Para apertar Gire no sentido horário.
 Después de colocar las piezas, coloque el tambor con su flecha hacia el tornillo. Para apretar, gire en sentido horario.
 After fitting the parts, place the drum with its arrow facing the screw. To tighten, turn clockwise.

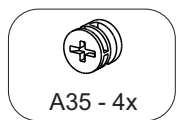

A35 - 4x

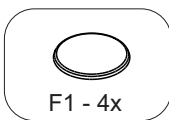

F1 - 4x

5

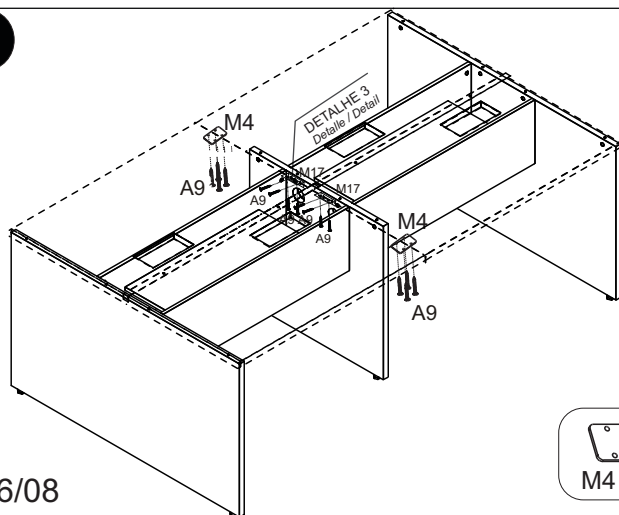

DETALHE 3
 Detalhe / Detail

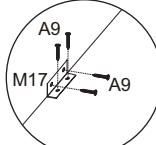

Posicione a cantoneira encostada na quina das peças.
 Coloque la ángulo contra la esquina de las piezas.
 Position the corner against the corner of the pieces.

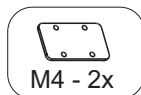

M4 - 2x

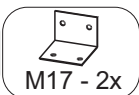

M17 - 2x

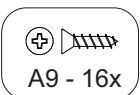

A9 - 16x

06/08

ACESSÓRIOS ACCESSORIES ACCESORIOS

A9 - PARAF. 4,0x16 CC
36x



A29 - PARAF. MINIFIX
 M6x33m **12x**

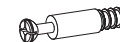

A24 - PARAF. 5,0x60 CF
2x



(Para fixação dos painéis divisores sem pitão)

A36 - BUCHA M6x13
12x



A35 - TAMBOR MINIFIX
12x



L5 - BUCHA PLÁSTICA
 P/SAPATA 5/16 **2x**



F2 - TAPA FURO Ø8
2x



M4 - CHAPA P/CONEXÃO
 05 FUROS **2x**

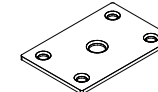

L2 - SAPATA PLAST.
 SEXT. **2x**



M6 - CANTONEIRA L
 4 FUROS 34x34MM **3x**



B8 - DISTANCIADOR
 50x24x10 **4x**



T9 - CAIXA DE TOMADA
2x

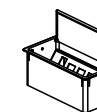

B1 - SUPORTE PRAT.
 METÁLICO **8x**



03/08

1 PRÉ-MONTAGEM

Preasamblea
Pre-assembly

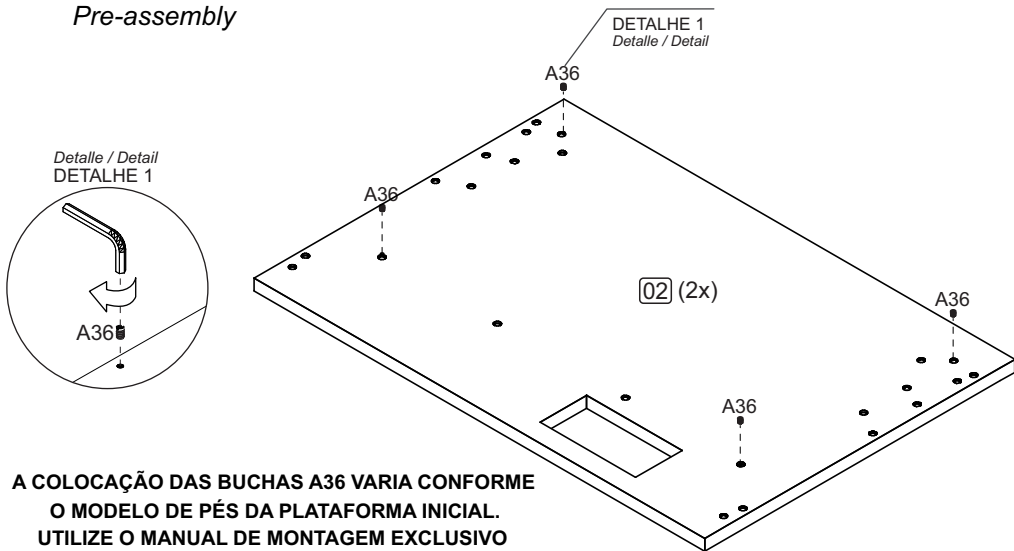

A COLOCAÇÃO DAS BUCHAS A36 VARIA CONFORME O MODELO DE PÉS DA PLATAFORMA INICIAL. UTILIZE O MANUAL DE MONTAGEM EXCLUSIVO DE CADA PLATAFORMA INICIAL.

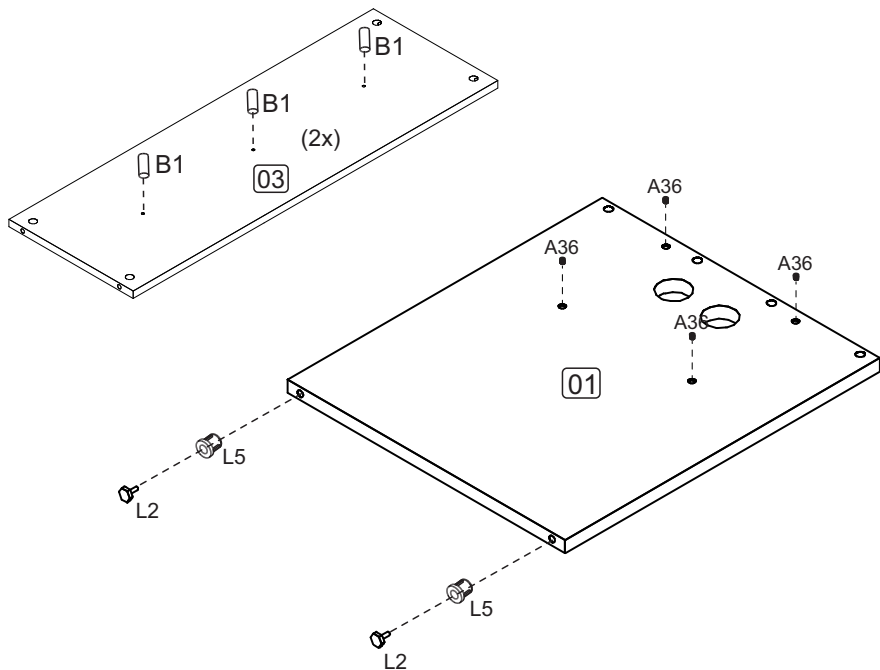

B1 - 6x

A36 - 4x

L2 - 2x

L5 - 2x

04/08

2 MONTAGEM

Armado
Assembly

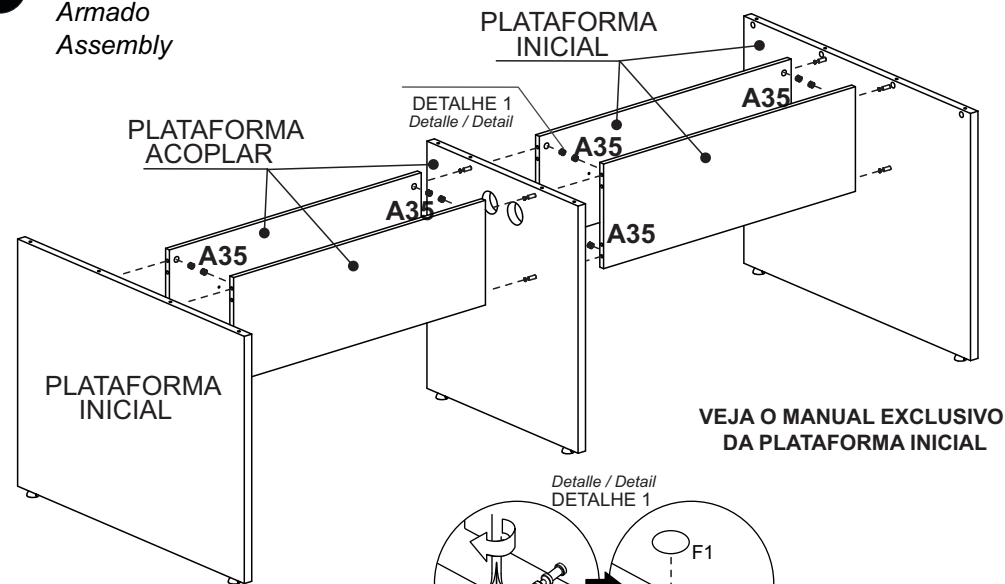

VEJA O MANUAL EXCLUSIVO DA PLATAFORMA INICIAL

Depois de encaixar as peças coloque o tambor com a sua seta voltada para o parafuso. Para apertar Gire no sentido horário.
Después de colocar las piezas, coloque el tambor con su flecha hacia el tornillo. Para apretar, gire en sentido horario.
After fitting the parts, place the drum with its arrow facing the screw. To tighten, turn clockwise.

A35 - 4x

3

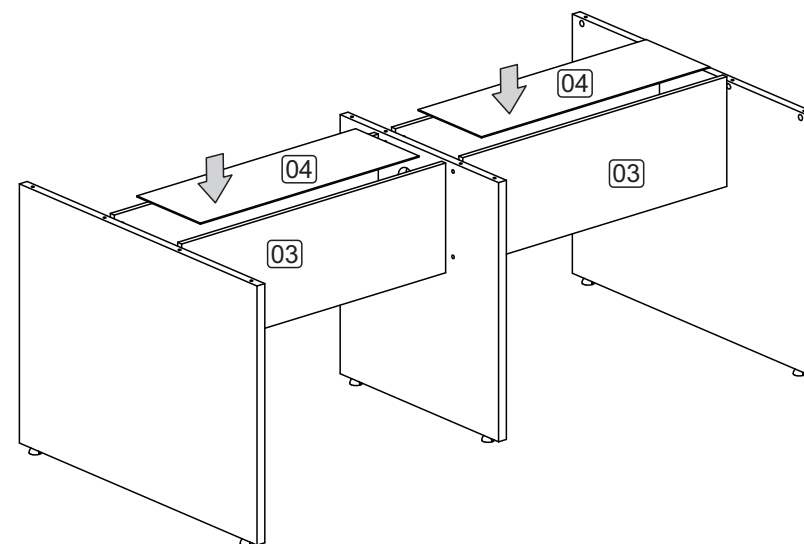

05/08