

## Capacidade de Carga - Load Capacity - Capacidad de carga

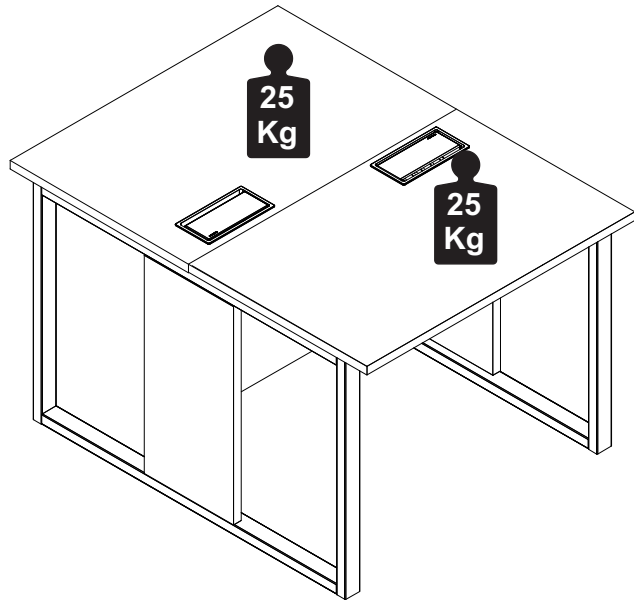

### Manutenção e Limpeza

Vidros: pano levemente umedecido com álcool, seguido de pano seco.  
Madeiras: pano levemente umedecido com água, seguido de pano seco.  
\*Nunca utilizar produtos químicos ou abrasivos.

### Maintenance and Cleaning

Glasses: cloth lightly moistened with alcohol, followed by dry cloth.  
Woods: cloth slightly moistened with water, followed by cloth seo.  
\*Never use chemicals or abrasives.

### Mantenimiento y Limpieza

Vidrios: legeramente humedecido con alcohol, seguido de un paño seco.  
Madera: ligeramente humedecido con agua, seguido de un paño seco.  
\*No utilice nunca productos quimicos o abrasivos.

## INSTRUÇÕES DE MONTAGEM ASSEMBLY INSTRUCTIONS INSTRUCCIONES DE MONTAJE

### PLATAFORMA DUPLA PÉ QUADRO TABLE FOOT DOUBLE PLATFORM PIES DE MESA PLATAFORMA DOBLE

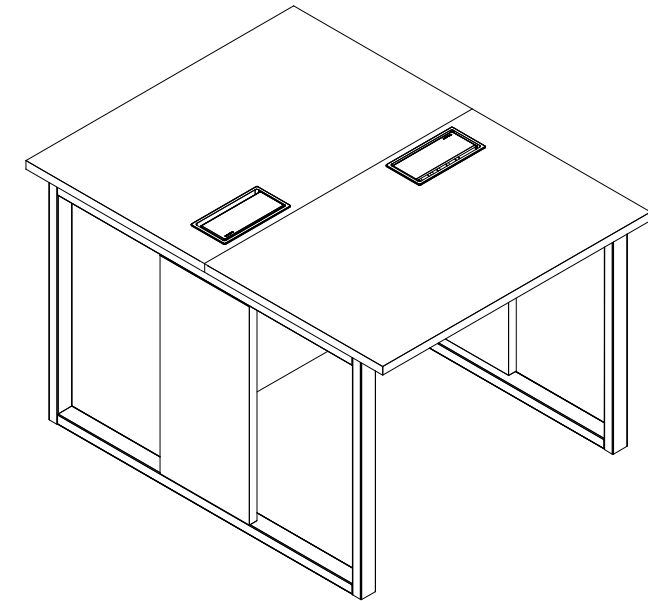

1 P.



8mm



35min

REF. #VRA9014-1214-1314-1514

 **Gebbwork**

MOBILIÁRIO  
PARA ESCRITÓRIO

GEBB Work Ind. de Móveis Ltda.  
Rua Felix Roman, 190  
São Valentin

95709-170 - Bento Gonçalves - RS - Brasil  
Fone: (0XX54) 3454-1105 - (0XX54) 3453-1407  
Phone: (0XX54) 3454-1105 - (0XX54) 34531407

E-mail: [pedidos@gebbwork.com.br](mailto:pedidos@gebbwork.com.br)

[www.gebbwork.com.br](http://www.gebbwork.com.br)

WhatsApp: +55 54 99177-8324

## LISTA DE PEÇAS

- 01 - Tampo
- 02 - Pé Lateral Quadro
- 03 - Painel Frontal
- 04 - Aplique Lateral
- 05 - Travessa Inferior

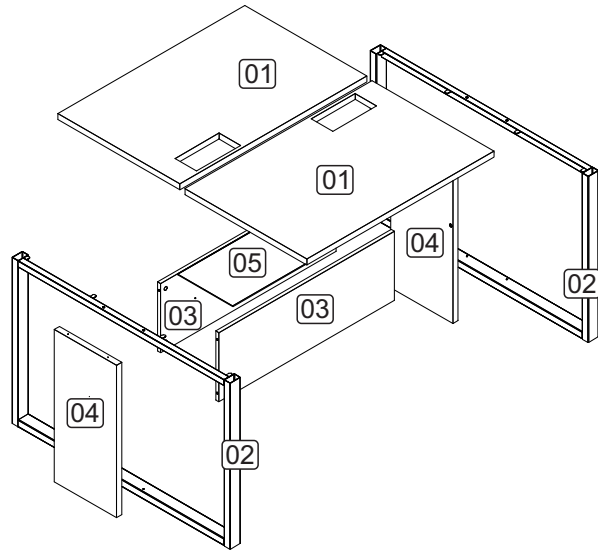

## LISTA DE PIEZAS

- 01 - Tapa
- 02 - Pata Lateral
- 03 - Panel Delantero
- 04 - Cerramiento Lateral
- 05 - Traviesa Inferior

## PARTS IDENTIFICATION

- 01 - Top
- 02 - Side Panel
- 03 - Front Panel
- 04 - Side Closure
- 05 - Lower Traverse

## GABARITO DE POSIÇÃO

Plantilla de posición  
Position template

Posicione o Tampo sobre a estrutura metálica conforme as medidas a baixo.  
Position the worktop over the metal structure according to the measurements below.  
Coloque la encimera sobre la estructura metálica según las siguientes medidas.

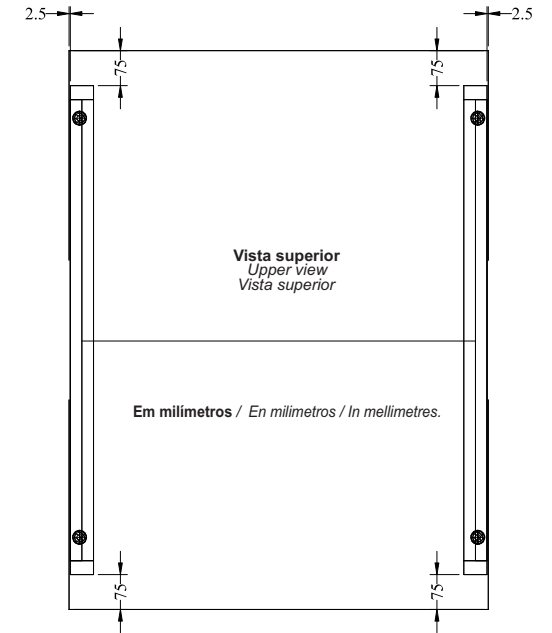

7

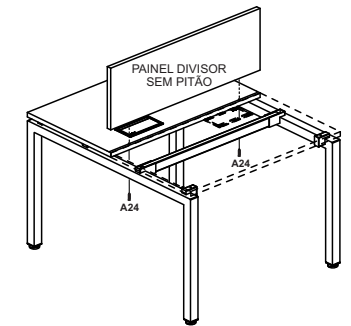
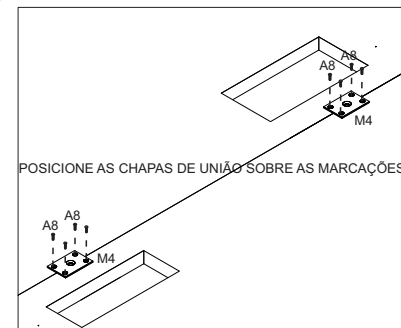

UTILIZE A FURAÇÃO CENTRAL COMO GABARITO  
REPASSE A FURAÇÃO COM BROCA Ø8mm

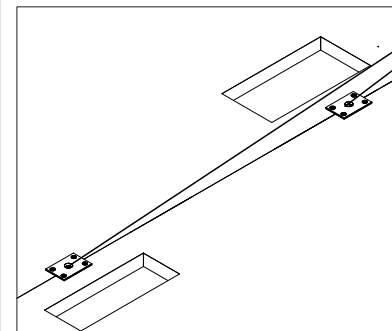

PARA INSTALAÇÃO DE PAINÉS DIVISORES COM USO DE PITÕES UTILIZE O MANUAL DE MONTAGEM EXCLUSIVO EXCLUSIVO DE CADA TIPO DE PITÃO



5

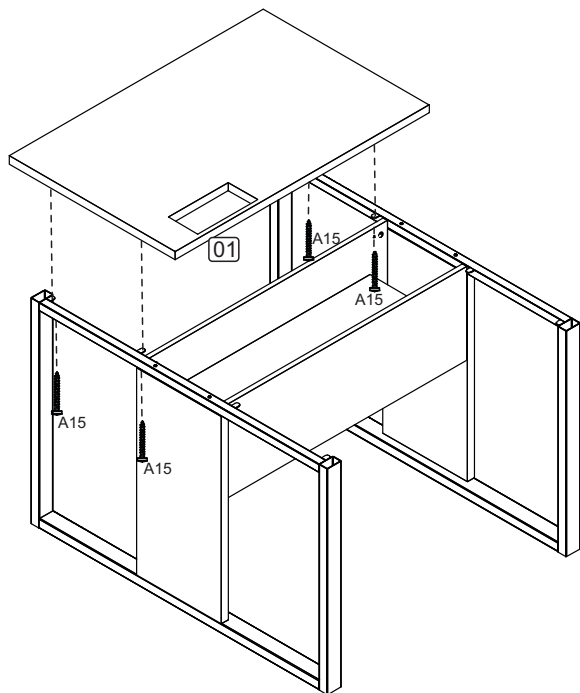

A15 - 4x

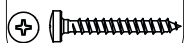

6

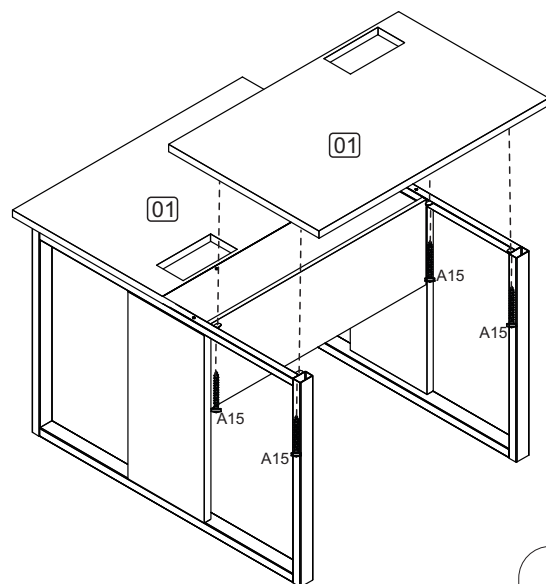
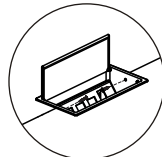
Detalle / Detail  
DETALHE 1Ver manual de montagem da caixa.  
Consulte el manual de montaje de la caja.  
See box assembly manual.

T9 - 2x

A15 - 4x

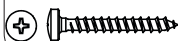

06/08

# ACESSÓRIOS ACCESSORIES ACCESORIOS

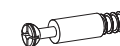
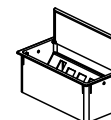
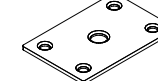
A15 - PARAF. 4,0x40 CP  
8xA9 - PARAF. 4,0x16 CC  
8xA24 - PARAF. 5,0x60 CF  
2x(Para fixação dos painéis  
divisores sem pitão)A36 - BUCHA M6x13  
8xA29 - PARAF. MINIFIX  
M6x33m 8xA35 - TAMBOR  
MINIFIX 8xL5 - BUCHA PLÁSTICA  
P/SAPATA 5/16 4xB1 - SUPORTE PRAT.  
METÁLICO 8xL2 - SAPATA PLAST.  
SEXT. 4xT9 - CAIXA DE TOMADA  
2xM4 - CHAPA P/CONEXÃO  
05 FUROS 4x

03/08

# 1 PRÉ-MONTAGEM

Preasamblea  
Pre-assembly

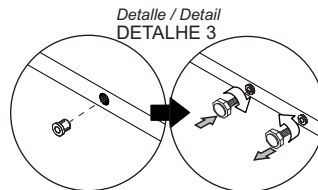
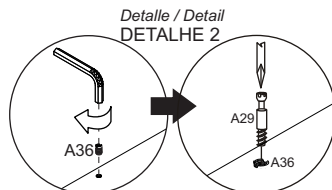
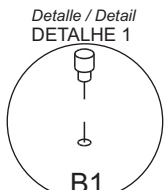
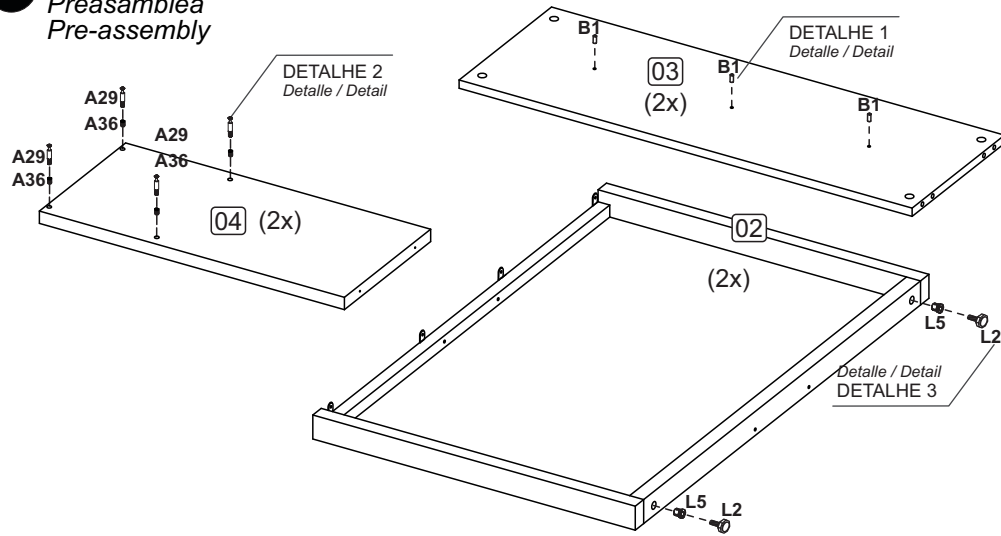

Se necessário utilize um martelo de borracha.  
Si es necesario, utilice un martillo de goma.  
If necessary, use a rubber hammer.

Com uma chave allen insira a bucha na peça, após, rosqueie o parafuso.  
Con una llave Allen, inserte el mandril en la pieza y luego atornille el tornillo.  
Using an Allen key, insert the chuck into the part, then screw the screw.

Insira a bucha com um martelo rosqueie a sapata.  
Inserte el portabrocas con un martillo atornille la zapata.  
Insert the chuck with a hammer and screw the shoe.

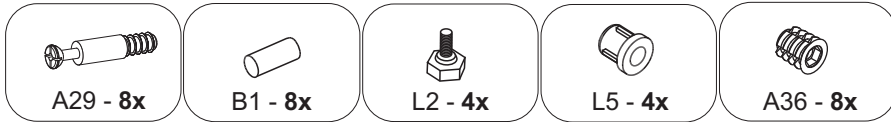

# 2 MONTAGEM

Armado  
Assembly

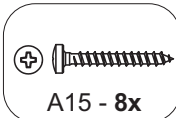
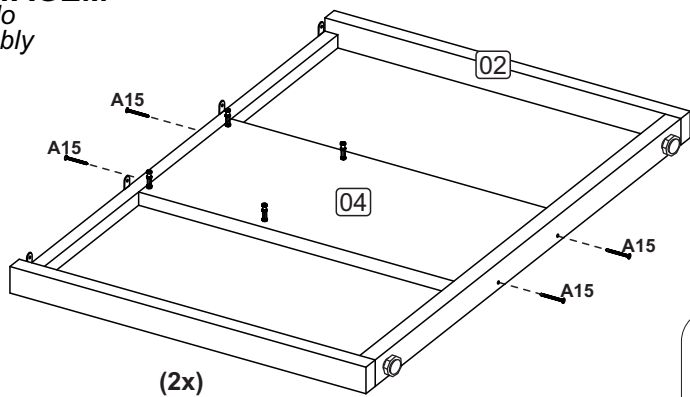

# 3

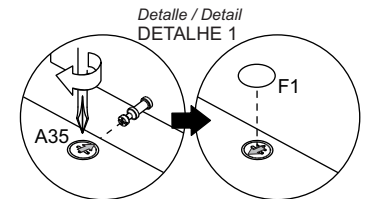
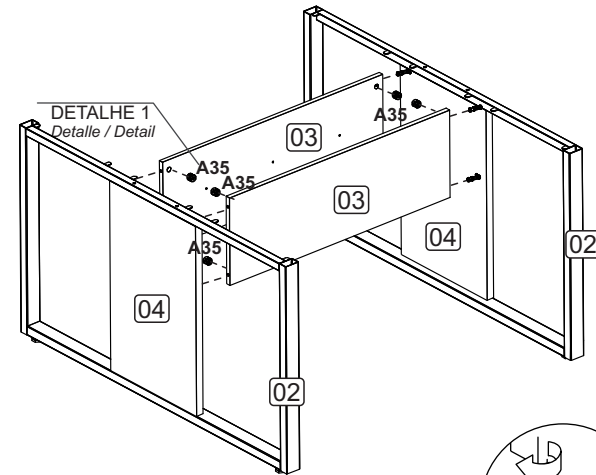

Depois de encaixar as peças coloque o tambor com a sua seta voltada para o parafuso. Para apertar Gire no sentido horário.  
Después de colocar las piezas, coloque el tambor con su flecha hacia el tornillo. Para apretar, gire en sentido horario.  
After fitting the parts, place the drum with its arrow facing the screw.  
To tighten, turn clockwise.

# 4

