

Capacidade de Carga - Load Capacity - Capacidad de carga

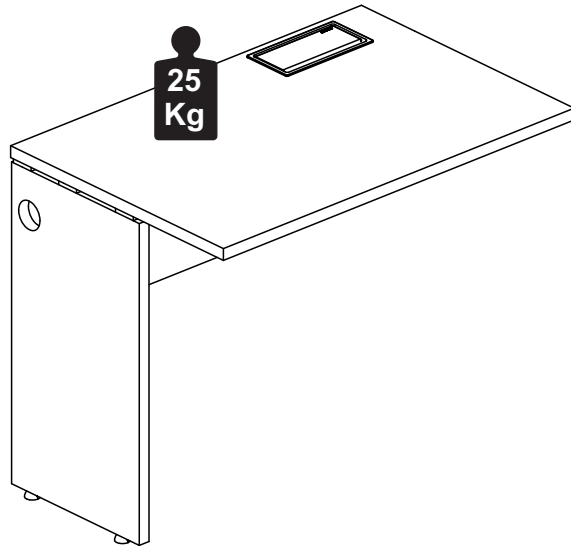

Manutenção e Limpeza

Vidros: pano levemente umedecido com álcool, seguido de pano seco.
Madeiras: pano levemente umedecido com água, seguido de pano seco.
*Nunca utilizar produtos químicos ou abrasivos.

Maintenance and Cleaning

Glasses: cloth lightly moistened with alcohol, followed by dry cloth.
Woods: cloth slightly moistened with water, followed by cloth seo.
*Never use chemicals or abrasives.

Mantenimiento y Limpieza

Vidrios: legeramente humedecido con alcohol, seguido de un paño seco.
Madera: ligeramente humedecido con agua, seguido de un paño seco.
*No utilice nunca productos quimicos o abrasivos.

INSTRUÇÕES DE MONTAGEM ASSEMBLY INSTRUCTIONS INSTRUCCIONES DE MONTAJE

PLATAFORMA SIMPLES ACOPLAR PLATAFORMA SIMPLE SIMPLE PLATFORM

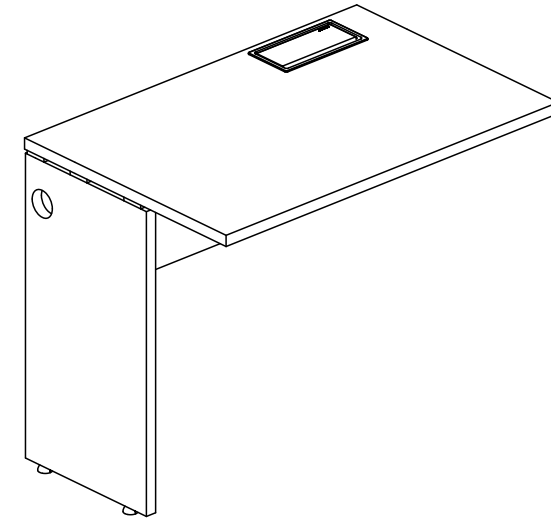

REF. #VRA5063-5263-5363-5563

REF. #EXP5063-5263-5363-5563



MOBILIÁRIO
PARA ESCRITÓRIO
GEBB Work Ind. de Móveis Ltda.
Rua Felix Roman, 190
São Valentin

95709-170 - Bento Gonçalves - RS - Brasil
Fone: (0XX54) 3454-1105 - (0XX54) 3453-1407
Phone: (0XX54) 3454-1105 - (0XX54) 3453-1407

E-mail: pedidos@gebbwork.com.br

www.gebbwork.com.br

WhatsApp: +55 54 99177-8324



1 P.



8mm



20mm

LISTA DE PEÇAS

- 01 - Tampo
- 02 - Painel Central
- 03 - Travessa Inferior
- 04 - Painel Frontal

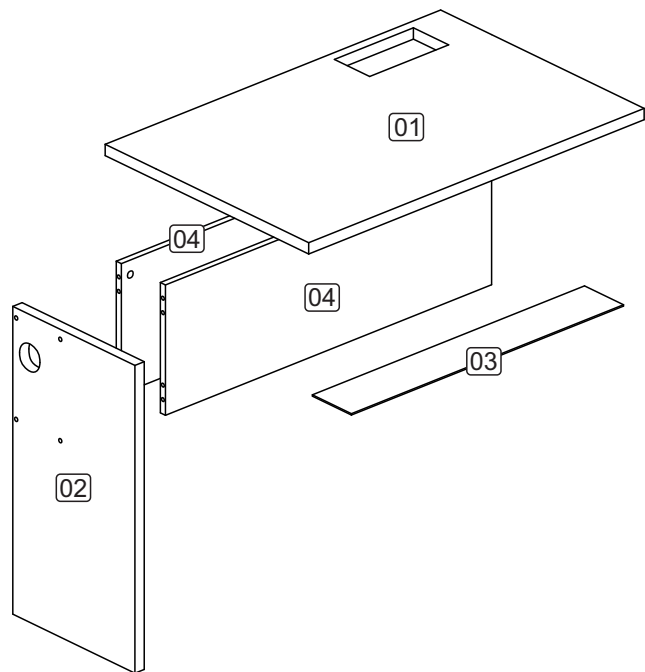

LISTA DE PIEZAS

- 01 - Tapa
- 02 - Panel Central
- 03 - Traviesa Inferior
- 04 - Panel Delantero

PARTS IDENTIFICATION

- 01 - Top
- 02 - Center Panel
- 03 - Lower Traverse
- 04 - Front Panel

6

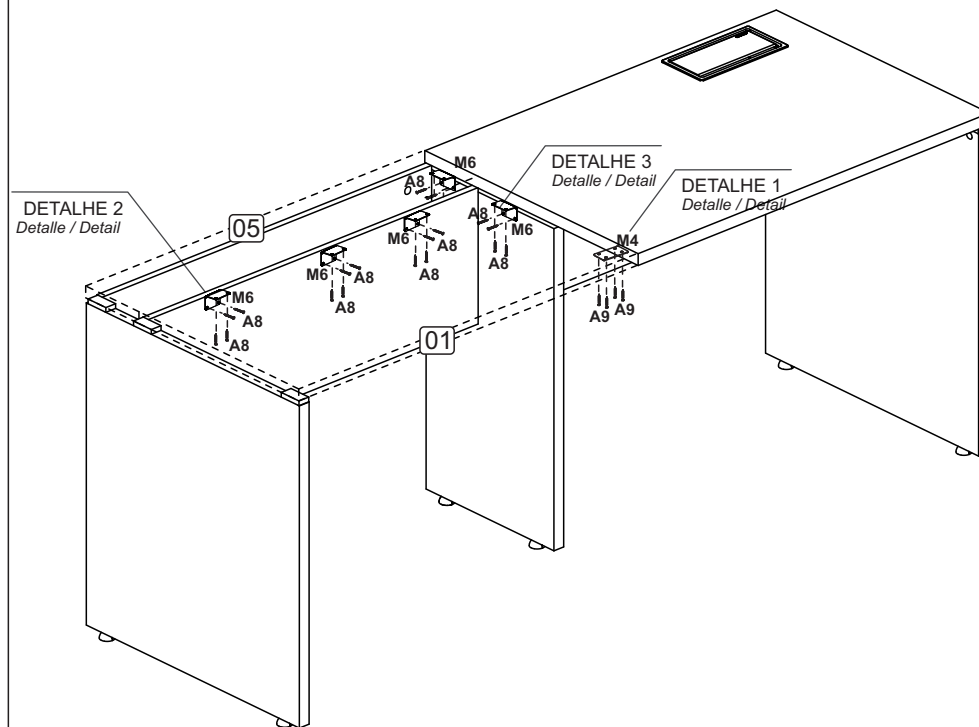

Detalle / Detail
DETALHE 1

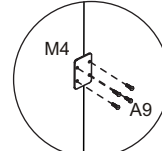

Coloque a Chapa centralizada entre as peças na vertical.
Colocar la placa centralizada entre las piezas de forma vertical.
Place the centralized plate between the pieces vertical.

Detalle / Detail
DETALHE 3

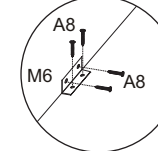

Posicione a cantoneira encostada na quina das peças.
Coloque la ángulo contra la esquina de las piezas.
Position the corner against the corner of the pieces.



A8 - 20x



A9 - 4x

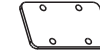

M4 - 1x



M6 - 5x

4

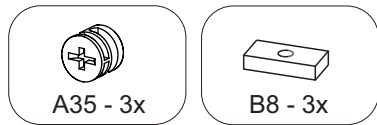
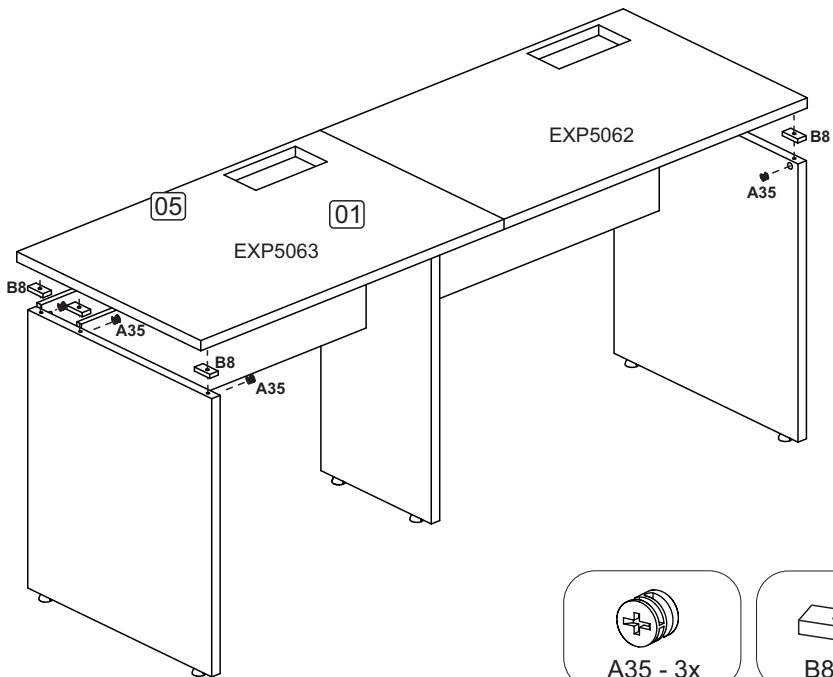

A35 - 3x

B8 - 3x

5

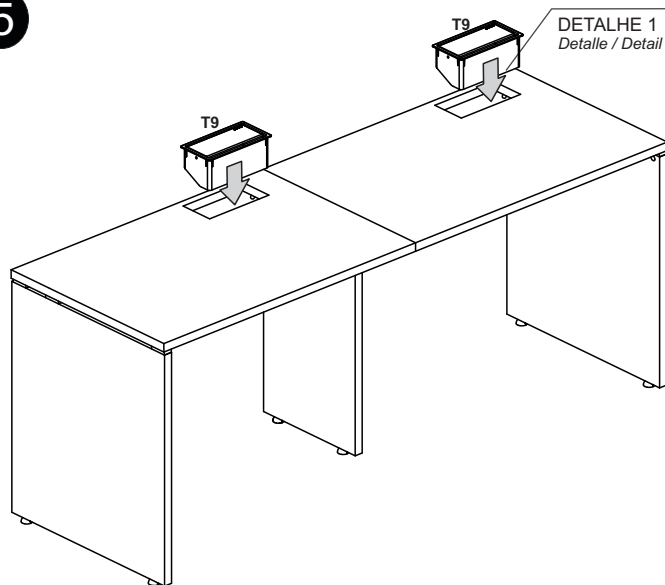

Ver manual de montagem da caixa.
Consulte el manual de montaje de la caja.
See box assembly manual.

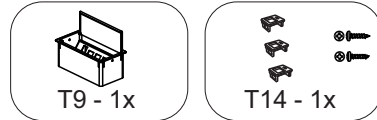

T9 - 1x

T14 - 1x

ACESSÓRIOS ACCESSORIES ACCESORIOS

- | | | |
|--|--|--|
| <p>A8 - PARAF. 4,0x14 CP
20x</p> | <p>A9 - PARAF. 4,0x16 CC
4x</p> | <p>A29 - PARAF. MINIFIX
M6x33m 11x</p> |
| <p>A35 - TAMBOR
MINIFIX 11x</p> | <p>A36 - BUCHA M6x13
11x</p> | <p>B1 - SUPORTE PRAT.
METÁLICO 6x</p> |
| <p>B8 - DISTANCIADOR
50x24x10 3x</p> | <p>F1 - TAPA FURO Ø18
4x</p> | <p>L2 - SAPATA PLAST.
SEXT. 2x</p> |
| <p>L5 - BUCHA PLÁSTICA
P/SAPATA 5/16 2x</p> | <p>M4 - CHAPA P/CONEXÃO
04 FUROS 1x</p> | <p>M6 - CANTONEIRA L
4 FUROS 34x34MM 5x</p> |
| <p>T9 - CAIXA DE TOMADA
PLÁSTICA 1x</p> | <p>T14 - KIT P/CAIXA DE
TOMADA 1x</p> | <p>T10 - BASE PASSA CABO
25x60 PTO. 1x</p> |

1 PRÉ-MONTAGEM

Pre-assembly
Pre-assembly

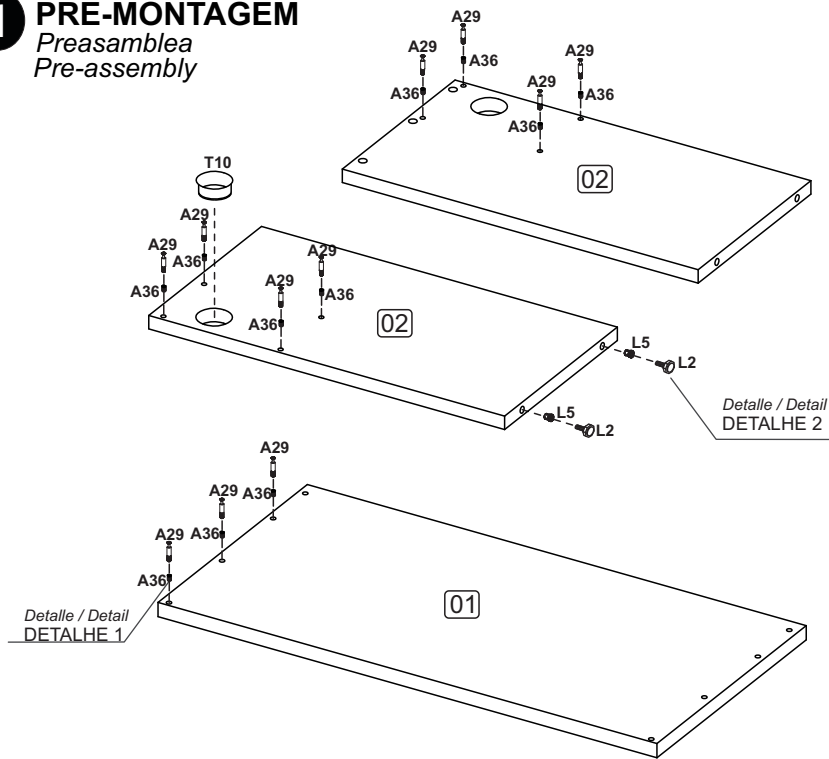

Detalle / Detail
DETALHE 1

Detalle / Detail
DETALHE 2

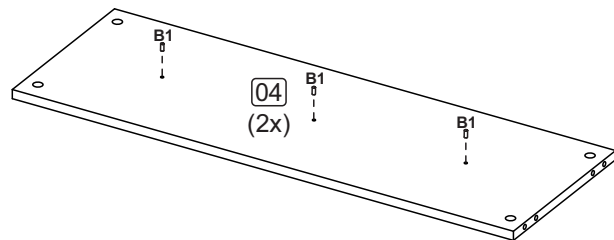

Detalle / Detail
DETALHE 1

Detalle / Detail
DETALHE 2

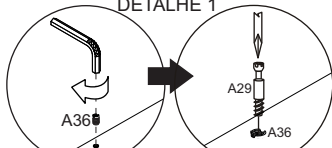

Com uma chave allen insira a bucha na peça, apos, rosqueie o parafuso. Con una llave Allen, inserte el mandril en la pieza y luego atornille el tornillo. Using an Allen key, insert the chuck into the part, then screw the screw.

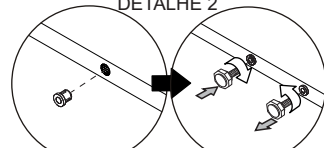

Insira a bucha com um martelo e rosqueie a sapatá. Inserte el portábocas con un martillo y atornille la zapata. Insert the chuck with a hammer and screw the shoe.

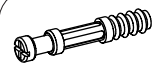

A29 - 11x



A36 - 11x



B1 - 6x



L2 - 2x



L5 - 2x



T10 - 1x

04/08

2 MONTAGEM

Armado
Assembly

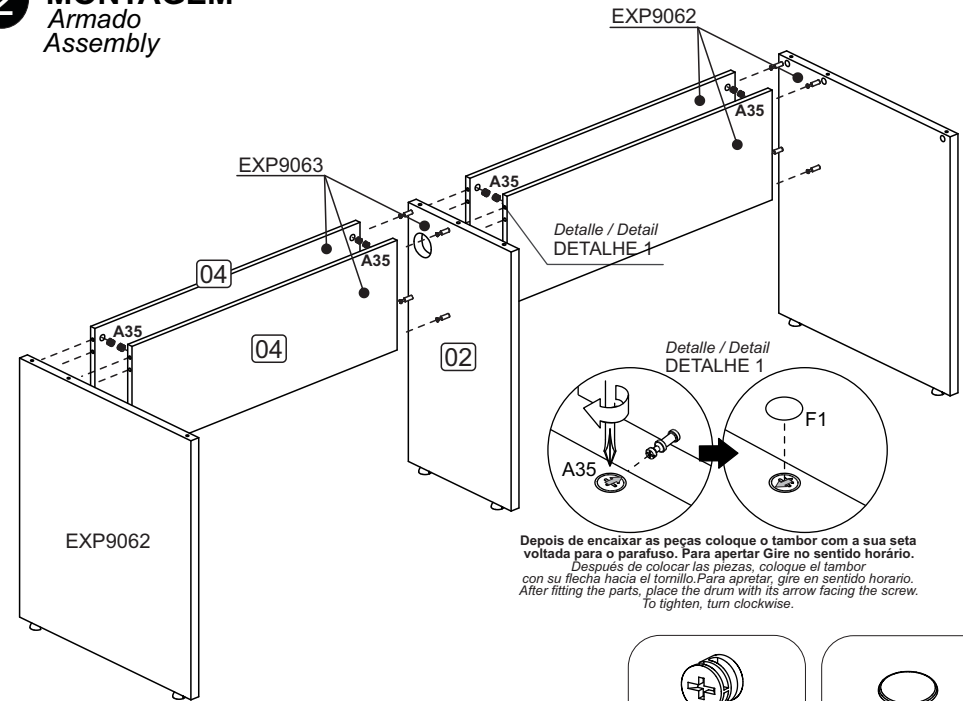

Depois de encaixar as peças coloque o tambor com a sua seta voltada para o parafuso. Para apertar Gire no sentido horário. Después de colocar las piezas, coloque el tambor con su flecha hacia el tornillo. Para apretar, gire en sentido horario. After fitting the parts, place the drum with its arrow facing the screw. To tighten, turn clockwise.



A35 - 8x



F1 - 2x

3

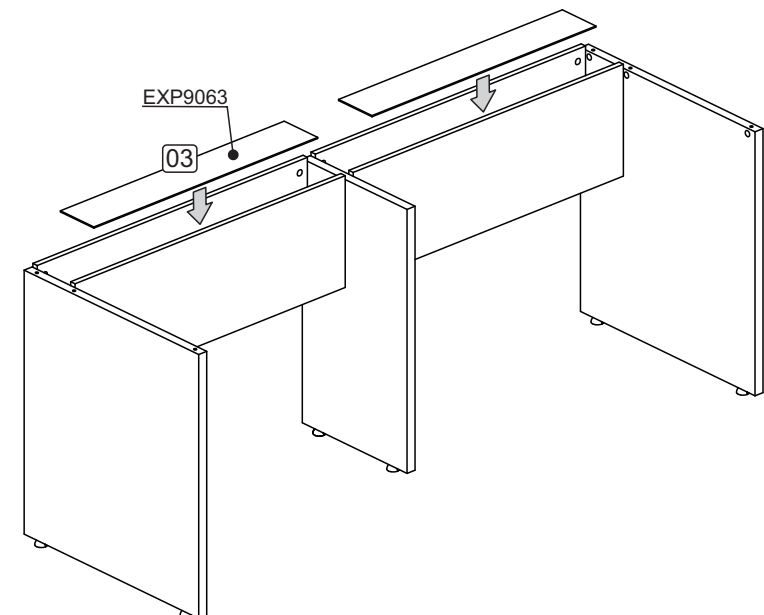

05/08