

Capacidade de Carga - Load Capacity - Capacidad de carga

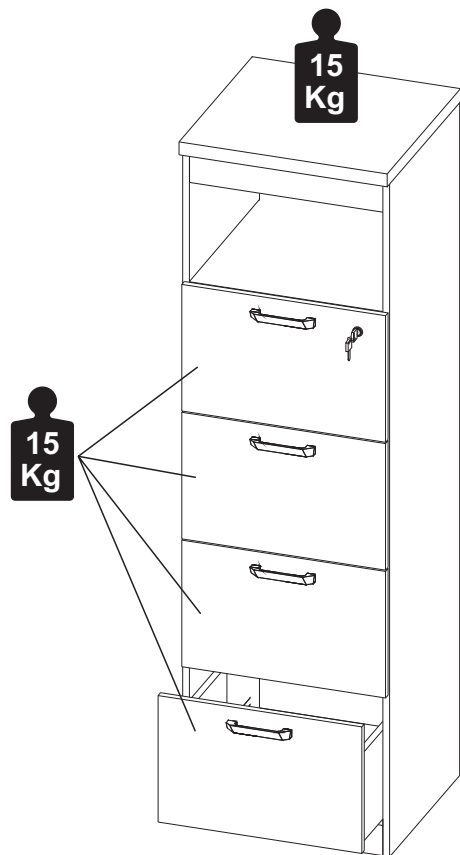

Manutenção e Limpeza

Vidros: pano levemente umedecido com álcool, seguido de pano seco.
Madeiras: pano levemente umedecido com água, seguido de pano seco.
*Nunca utilizar produtos químicos ou abrasivos.

Maintenance and Cleaning

Glasses: cloth lightly moistened with alcohol, followed by dry cloth.
Woods: cloth slightly moistened with water, followed by cloth seco.
*Never use chemicals or abrasives.

Mantenimiento y Limpieza

Vidrios: legeramente humedecido con alcohol, seguido de un paño seco.
Madera: ligeramente humedecido con agua, seguido de un paño seco.
*No utilice nunca productos quimicos o abrasivos.

INSTRUÇÕES DE MONTAGEM ASSEMBLY INSTRUCTIONS INSTRUCCIONES DE MONTAJE

GAVETEIRO DRAWERS CAJONERO

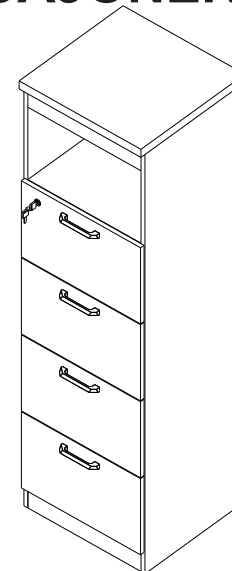

1 P.



35min

REF. #VRA4616

REF. #YAR4616



Gebbwork

MOBILIÁRIO
PARA ESCRITÓRIO

GEBB Work Ind. de Móveis Ltda.
Rua Felix Roman, 190
São Valentin

95709-170 - Bento Gonçalves - RS - Brasil
Fone: (0XX54) 3454-1105 - (0XX54) 3453-1407
Phone: (0XX54) 3454-1105 - (0XX54) 3453-1407

E-mail: pedidos@gebbwork.com.br

www.gebbwork.com.br

WhatsApp: +55 54 99177-8324

LISTA DE PEÇAS

LISTA DE PEÇAS

- 01 - Lateral Esquerda
- 02 - Lateral Direita
- 03 - Tampo
- 07 - Frente Gav. Maior
- 08 - Frente Gaveta Tranca
- 09 - Base
- 11 - Fundo Gaveta
- 12 - Lateral Esq. Gav. Maior
- 13 - Lateral Dir. Gav. Maior
- 14 - Costa Gav. Maior
- 15 - Costa
- 16 - Rodapé

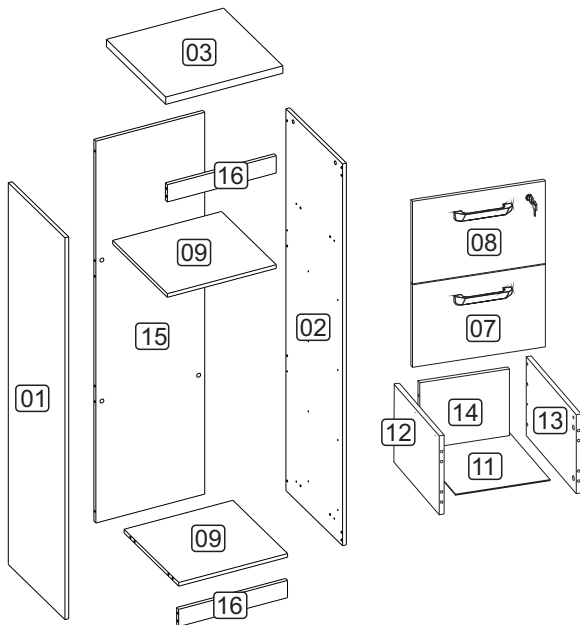

LISTA DE PIEZAS

- 01 - Lateral Izquierda
- 02 - Lateral Derecha
- 03 - Tampo
- 07 - Frente Cajón Mayor
- 08 - Frente Cajón tranca
- 09 - Base
- 11 - Fondo Cajón
- 12 - Lateral Izquierda Cajón mayor
- 13 - Lateral Derecha Cajón Menor
- 14 - Revés Cajón Mayor
- 15 - Costa
- 16 - Pie

PARTS IDENTIFICATION

- 01 - Left Side
- 02 - Right Side
- 03 - Cover
- 07 - Large Front Drawer
- 08 - Front Drawer Locks
- 09 - Base
- 11 - Bottom Drawer
- 12 - Large Left Side Drawer
- 13 - Large Right Side Drawer
- 14 - Large Back Drawer
- 15 - Coast
- 16 - Footer

6

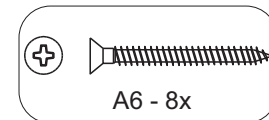
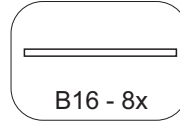
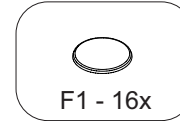
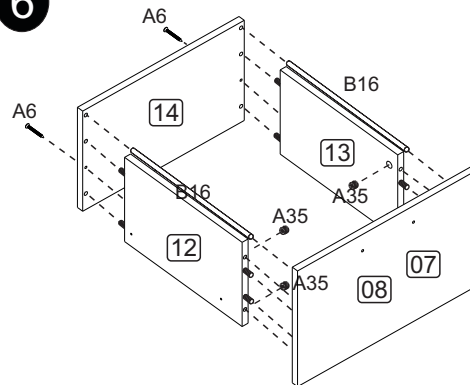

7

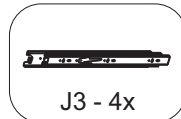
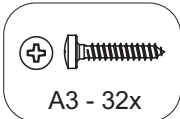
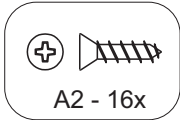
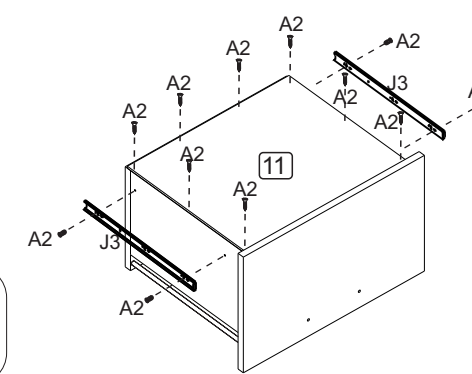

8

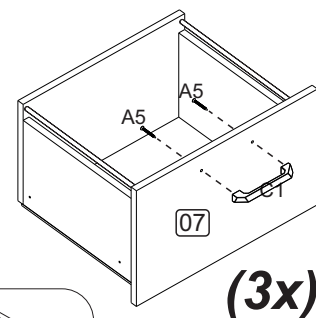

(3x)

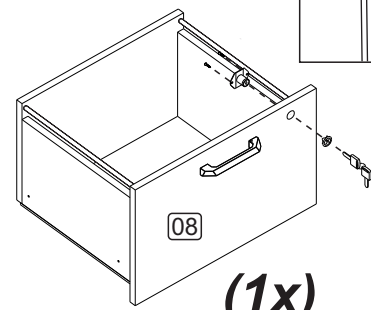

(1x)

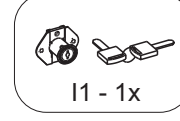
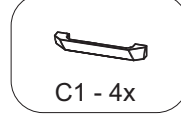
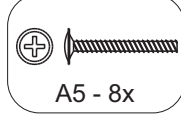
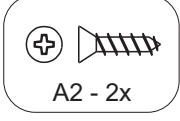
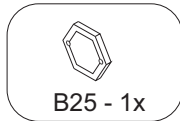

4

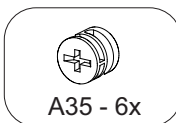
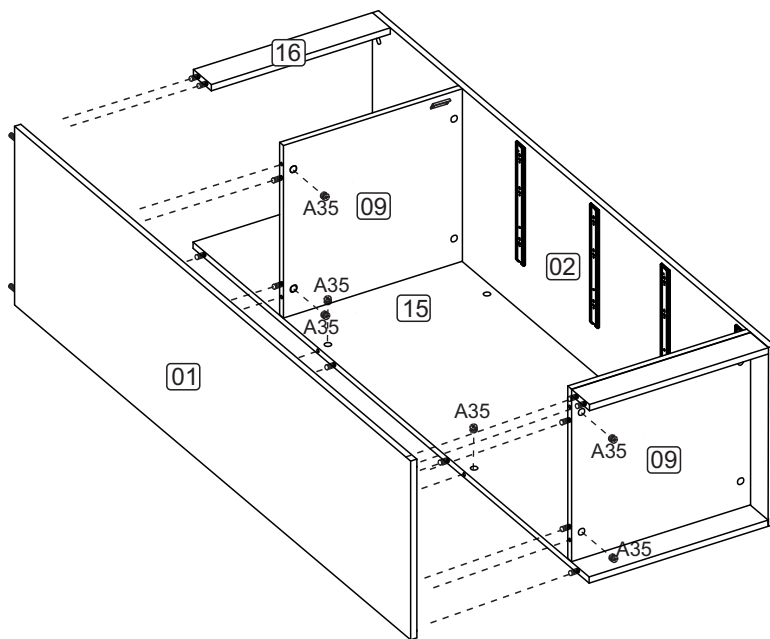

5

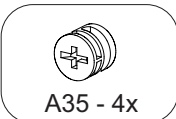
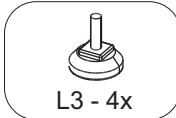
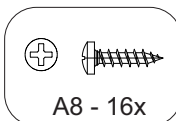
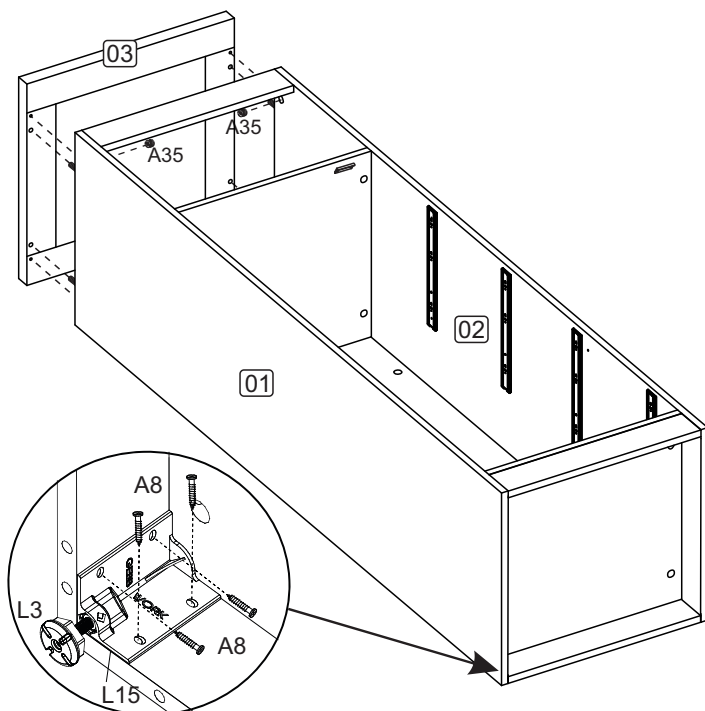

06/08

ACESSÓRIOS ACCESSORIES ACCESORIOS

A2 - PARAF. 3,5x14 CC
36x



A3 - PARAF. 3,5x20 CP
32x



A5 - PARAF. 3,5x25 CF
8x



A6 - PARAF. 3,5x40 CC
8x



A8 - PARAF. 4,0x14 CP
16x



A32 - PARAF. MINIFIX
32x

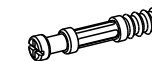

A35 - TAMBOR
MINIFIX **32x**



B16 - HASTE MET.
353mm **8x**



C1 - PUXADOR
4x



D1 - CAVILHA 8x30
60x

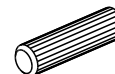

F1 - TAPA FURO Ø18
16x



I1 - FECHADURA P/GAV.
1x



J3 - CORREDIÇA
TELESC. 350mm **4x**



L3 - SAPATA PLAST. 1/4
4x



L15 - CANTONEIRA P/
SAPATA 70X40X40 **4x**



M2 - BATENTE P/PORTA
1x



B25 - SEPARADOR
P/ FECHADURA **1x**



03/08

1 PRÉ-MONTAGEM

Preasamblea
Pre-assembly

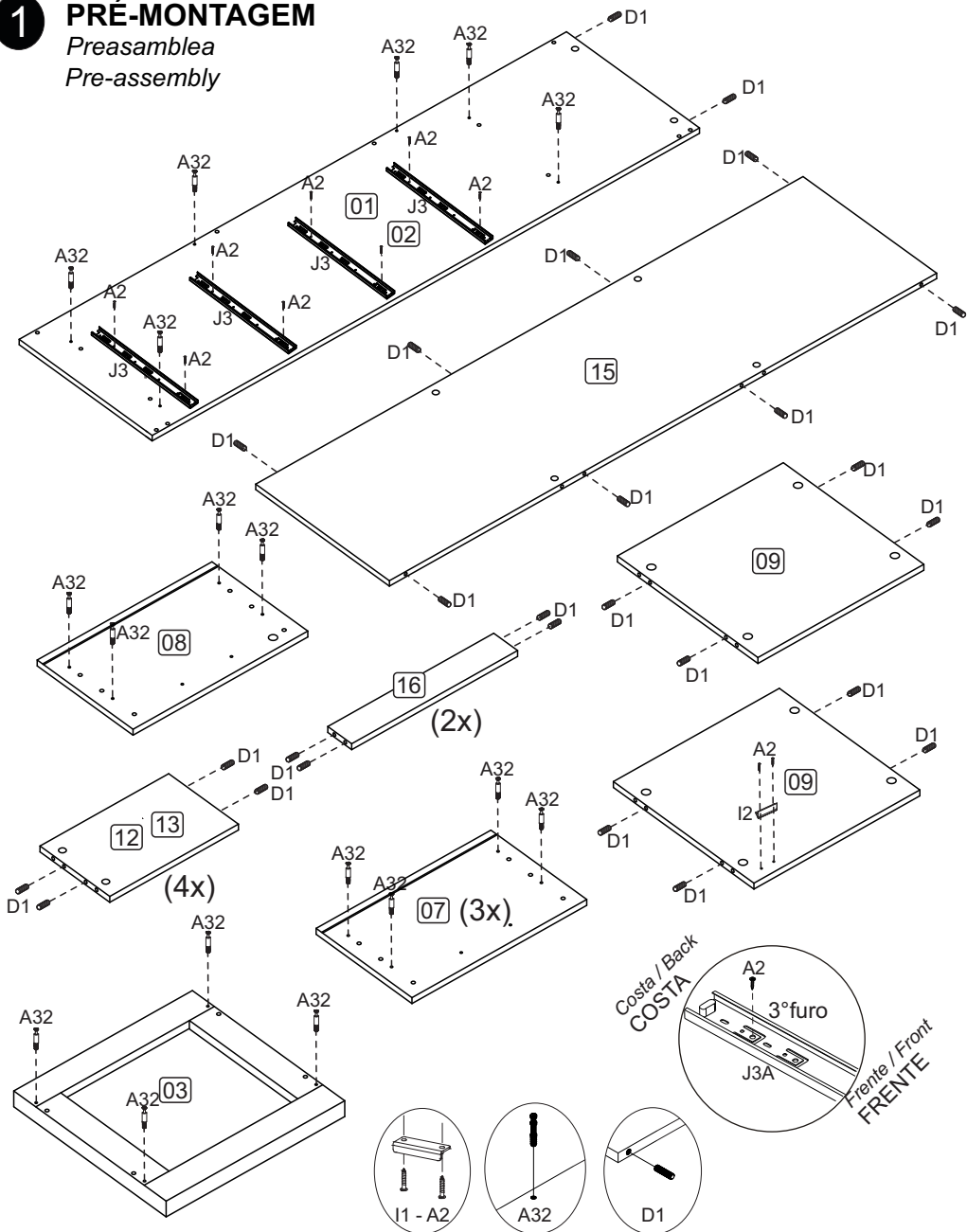

04/08

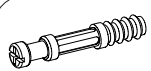

A32 - 32x

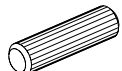

D1 - 60x



I1 - 1x



J3 - 4x



A2 - 18x

2

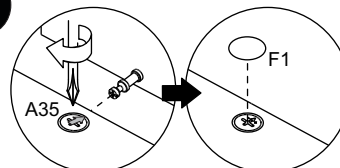

Depois de encaixar as peças coloque o tambor com a sua seta voltada para o parafuso. Para apertar Gire no sentido horário.
Después de colocar las piezas, coloque el tambor con su flecha hacia el tornillo. Para apretar, gire en sentido horario.
After fitting the parts, place the drum with its arrow facing the screw. To tighten, turn clockwise.

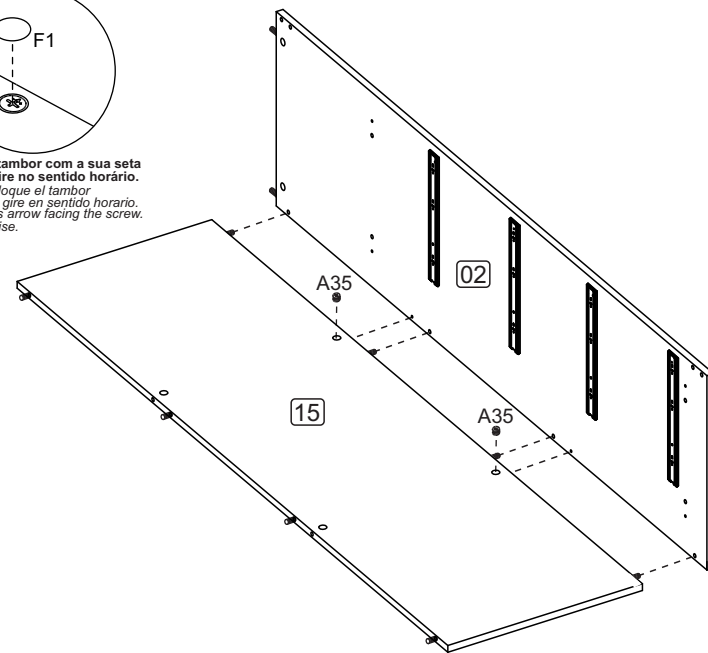

A35 - 2x

3

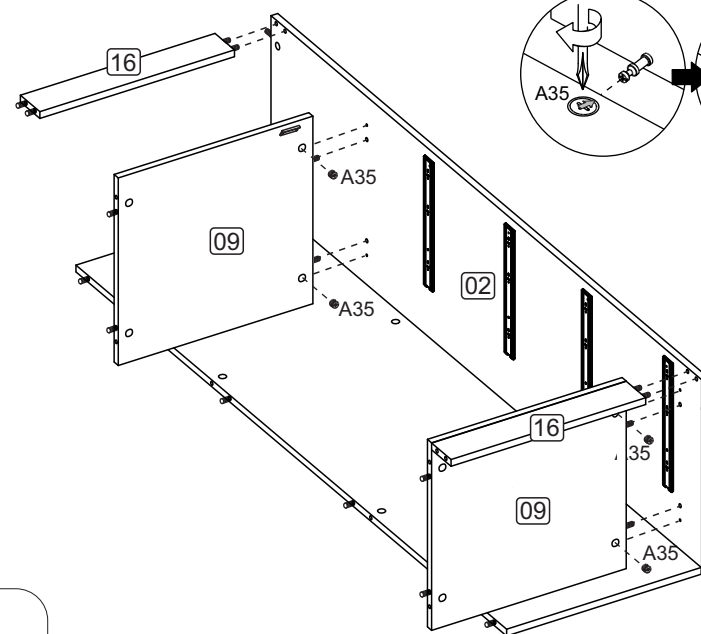
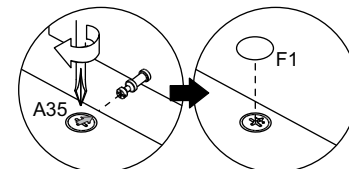

A35 - 4x

05/08