

## Capacidade de Carga - Load Capacity - Capacidad de carga

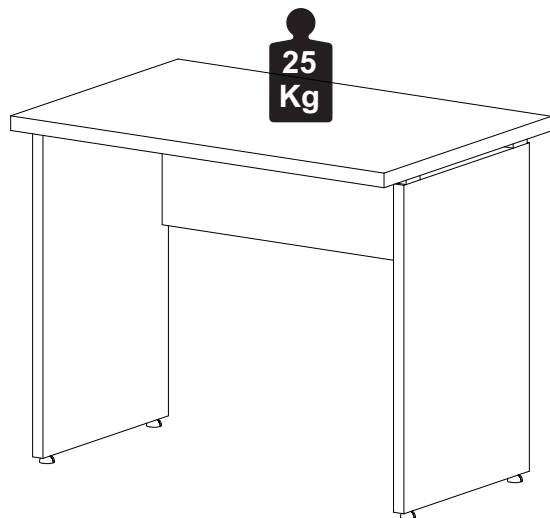

### Manutenção e Limpeza

Vidros: pano levemente umedecido com álcool, seguido de pano seco.  
Madeiras: pano levemente umedecido com água, seguido de pano seco.  
\*Nunca utilizar produtos químicos ou abrasivos.

### Maintenance and Cleaning

Glasses: cloth lightly moistened with alcohol, followed by dry cloth.  
Woods: cloth slightly moistened with water, followed by cloth seo.  
\*Never use chemicals or abrasives.

### Mantenimiento y Limpieza

Vidrios: legeramente humedecido con alcohol, seguido de un paño seco.  
Madera: ligeramente humedecido con agua, seguido de un paño seco.  
\*No utilice nunca productos quimicos o abrasivos.

## INSTRUÇÕES DE MONTAGEM ASSEMBLY INSTRUCTIONS INSTRUCCIONES DE MONTAJE

### MESAS TABLES TABLAS

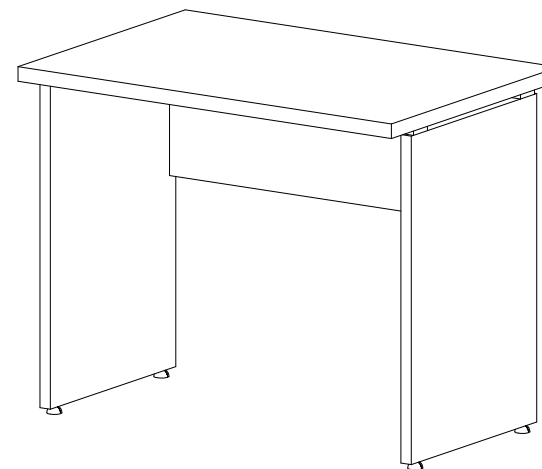

1 P.



8mm

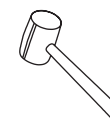

15mm

REF. #YAR 9060/1260/1360/1560  
REF. #EXP9060/1260/1360/1560



MOBILIÁRIO  
PARA ESCRITÓRIO

GEBB Work Ind. de Móveis Ltda.  
Rua Felix Roman, 190  
São Valentin

95709-170 - Bento Gonçalves - RS - Brasil  
Fone: (0XX54) 3454-1105 - (0XX54) 3453-1407  
Phone: (0XX54) 3454-1105 - (0XX54) 3453-1407

E-mail: [pedidos@gebbwork.com.br](mailto:pedidos@gebbwork.com.br)  
[www.gebbwork.com.br](http://www.gebbwork.com.br)

WhatsApp: +55 54 99177-8324

## LISTA DE PEÇAS

- 01 - Lateral Esquerda
- 02 - Lateral Direita
- 03 - Tampo
- 04 - Saia

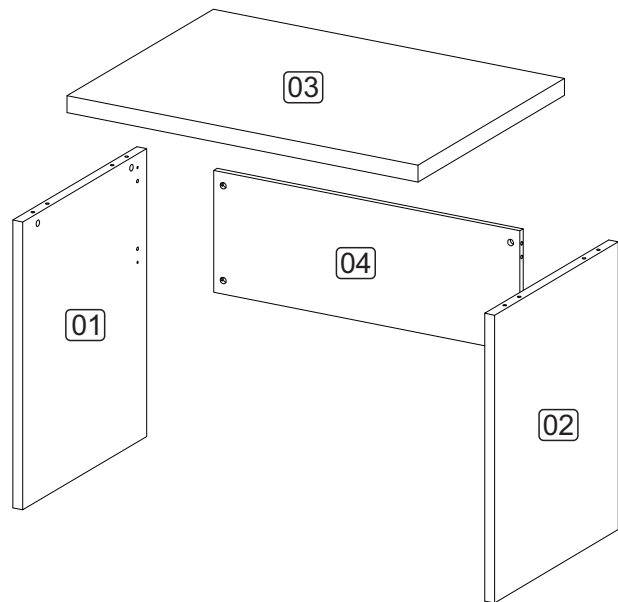

## LISTA DE PIEZAS

- 01 - Lateral Izquierda
- 02 - Lateral Derecha
- 03 - Tapa
- 04 - Revés

## PARTS IDENTIFICATION

- 01 - Left Side
- 02 - Right Side
- 03 - Top
- 04 - Back

### 3 PARA COMPENSAR A DIFERANÇA ENTRE A ALTURA DAS LATERAIS '01' E '02' E O PAINEL FRONTAL '04' UTILIZE O DISTANCIADOR 'B8'.

Para compensar la diferencia entre la altura de los lados '01' y '02' y el panel frontal '04' utilice el espaciador 'b8'.

To compensate for the difference between the height of the sides '01' and '02' and the front panel '04' use the spacer 'b8'.

Encaixe o distanciador 'B8' no parafuso 'A32' da peça '03'.  
Coloque el espaciador "B8" en el tornillo "A32" de la pieza "03".  
Fit the spacer 'B8' to the 'A32' screw of part '03'.

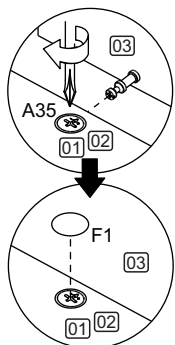
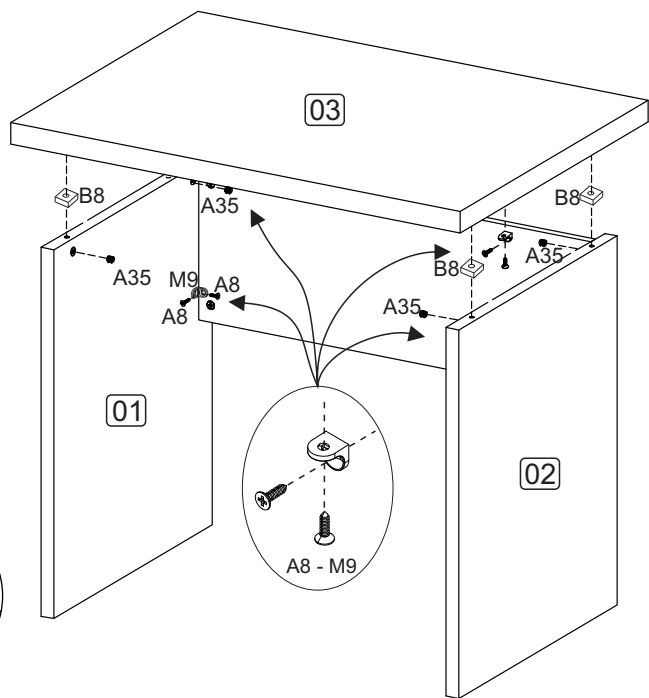

Girar os tambores em sentido horário



M9 - 4x



A35 - 4x



B8 - 4x



F1 - 4x



A8 - 8x

## ACESSÓRIOS ACCESSORIES ACCESORIOS

A8 - PARAF. 4,0x14 CP  
8x



A29 - PARAF. MINIFIX  
M6x33m 8x

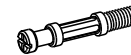

A35 - TAMBOR MINIFIX  
8x



A36 - BUCHA M6x13  
8x



B8 - DISTANCIADOR  
50x24x10 4x



D1 - CAVILHA 8x30  
4x

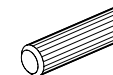

F1 - TAPA FURO Ø18  
8x



L2 - SAPATA PLAST. SEXT.  
4x



L5 - BUCHA PLÁSTICA  
P/SAPATA 5/16 4x



M9 - CANTONEIRA L  
2 FUROS ZAMAK 4x

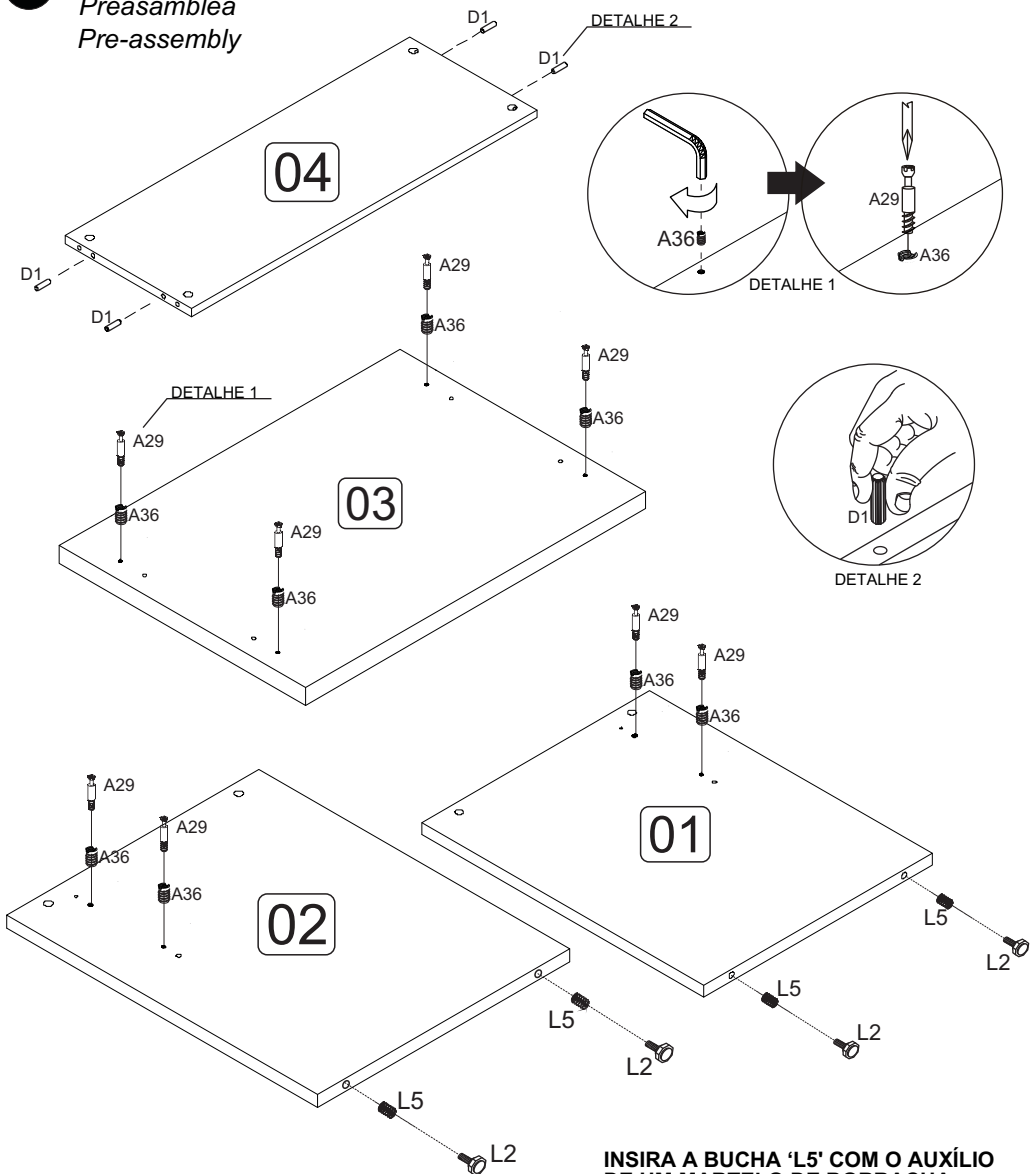

1

**PRÉ-MONTAGEM**Preasamblea  
Pre-assembly

**INSIRA A BUCHA 'L5' COM O AUXÍLIO DE UM MARTELO DE BORRACHA APÓS ROSQUEIE A SAPATA 'L2'.**

*Inserte el casquillo 'L5' con la ayuda de un martillo de goma y luego atornille la zapata 'L2'*  
*Insert the 'L5' bushing with the aid of a rubber hammer then screw in the 'L2' shoe*

04/08

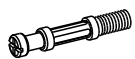

A29 - 8x



A36 - 8x



D1 - 4x



L2 - 4x



L5 - 4x

2

**MONTAGEM**Armado  
Assembly

**Encaixe a peça '04' nas peças '01' e '02' através dos parafusos 'A32' e Cavilha 'D1'.**  
*Ajuste la parte '04' a las partes '01' y '02' con los tornillos 'A32' y el perno 'D1'.*  
*Fit part '04' to parts '01' and '02' using screws 'A32' and Bolt 'D1'.*

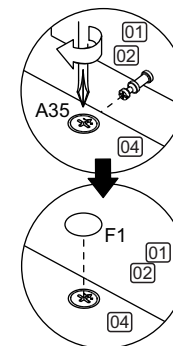
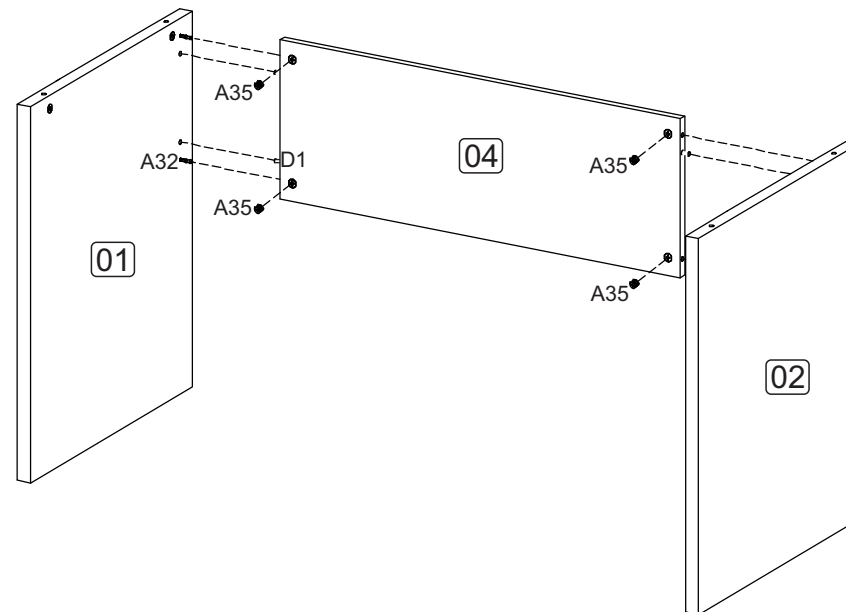

Girar os tambores em sentido horário



A35 - 4x



F1 - 4x

05/08