

Capacidade de Carga - Load Capacity - Capacidad de carga

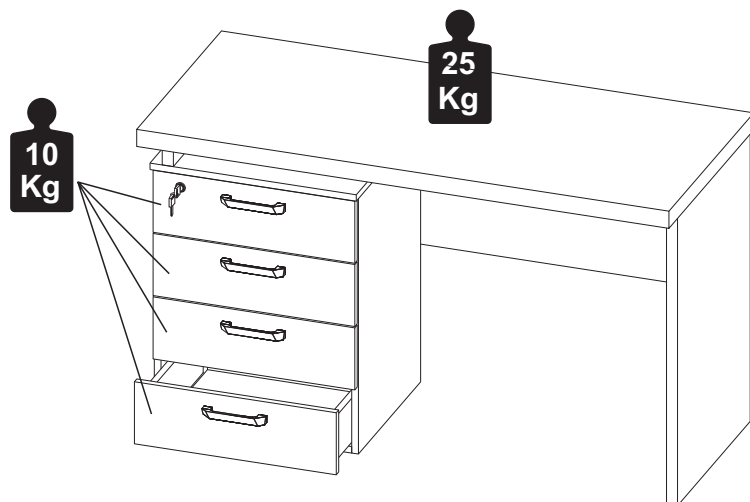

Manutenção e Limpeza

Vidros: pano levemente umedecido com álcool, seguido de pano seco.
Madeiras: pano levemente umedecido com água, seguido de pano seco.
*Nunca utilizar produtos químicos ou abrasivos.

Maintenance and Cleaning

Glasses: cloth lightly moistened with alcohol, followed by dry cloth.
Woods: cloth slightly moistened with water, followed by cloth seo.
*Never use chemicals or abrasives.

Mantenimiento y Limpieza

Vidrios: legeramente humedecido con alcohol, seguido de un paño seco.
Madera: ligeramente humedecido con agua, seguido de un paño seco.
*No utilice nunca productos quimicos o abrasivos.

INSTRUÇÕES DE MONTAGEM ASSEMBLY INSTRUCTIONS INSTRUCCIONES DE MONTAJE

GAVETEIRO DRAWERS CAJONERO

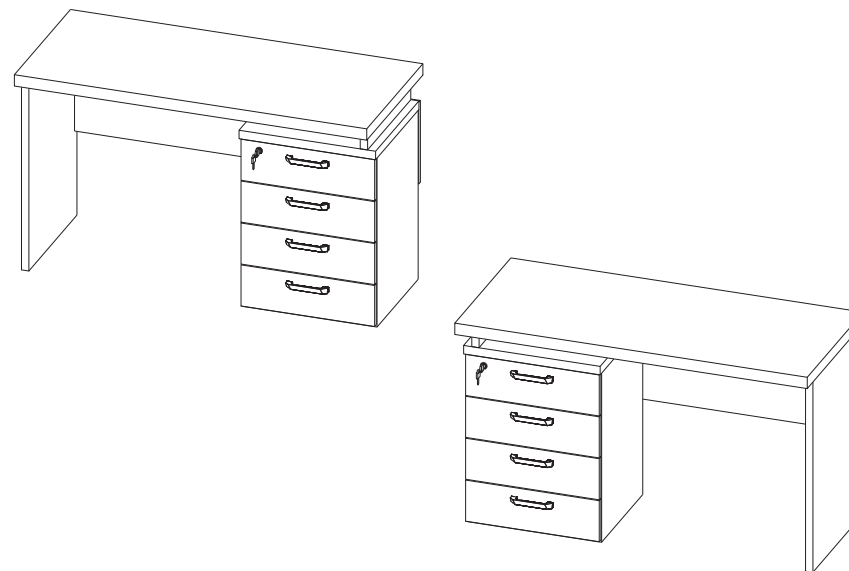

REF. #YAR 1253/1353/1553

 **GEBB WORK**
MOBILIÁRIO PARA ESCRITÓRIO

GEBB Work Ind. de Móveis Ltda.
Rua Felix Roman, 190
São Valentin

95709-170 - Bento Gonçalves - RS - Brasil
Fone: (0XX54) 3454-1105 - (0XX54) 3453-1407
Phone: (0XX54) 3454-1105 - (0XX54) 3453-1407
E-mail: pedidos@gebbwork.com.br

www.gebbwork.com.br
WhatsApp: +55 54 99177-8324

LISTA DE PEÇAS

LISTA DE PEÇAS

- 01 - Lateral Esquerda
- 02 - Lateral Direita
- 03 - Tampo
- 04 - Base
- 05 - Frente Gaveta
- 06 - Frente Gaveta c/Fechadura
- 08 - Lateral Esq. Gaveta
- 09 - Lateral Dir. Gaveta
- 10 - Costa Gaveta
- 11 - Fundo Gaveta
- 15 - Costa
- 16 - Travessa Superior
- 17 - Travessa Lateral
- 18 - Painel Lateral
- 19 - Tampo Engrossado
- 20 - Painel Frontal

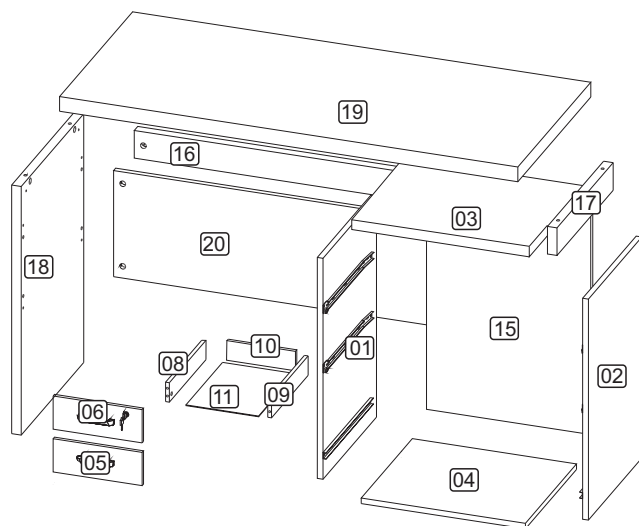

LISTA DE PIEZAS

- 01 - Lateral Izquierda
- 02 - Lateral Derecha
- 03 - Tampo
- 04 - Base
- 05 - Frente Cajón
- 06 - Frente Cajón tranca
- 08 - Lateral Izq. Cajón
- 09 - Lateral Der. Cajón
- 10 - Revés Cajón
- 11 - Fondo Cajón
- 15 - Costa
- 16 - Travessa Superior
- 17 - Travessa Lateral
- 18 - Panel Lateral
- 19 - Tampo Engrossado
- 20 - Panel Frontal

PARTS IDENTIFICATION

- 01 - Left Side
- 02 - Right Side
- 03 - Cover
- 04 - Base
- 05 - Drawer Front
- 06 - Front Drawer Locks
- 08 - Left Drawer Side
- 09 - Right Drawer Side
- 10 - Drawer Back
- 11 - Drawer Bottom
- 15 - Coast
- 16 - Dish
- 17 - Sid Dish
- 18 - Panel Side
- 19 - Cover
- 20 - Front Panel

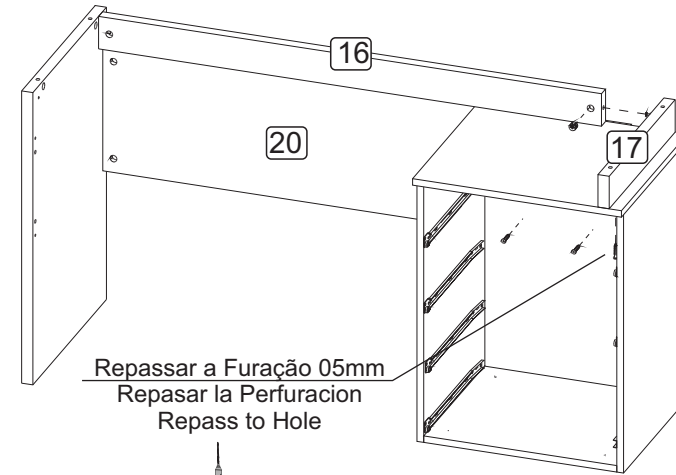
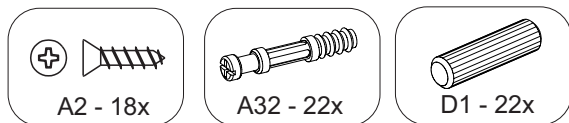
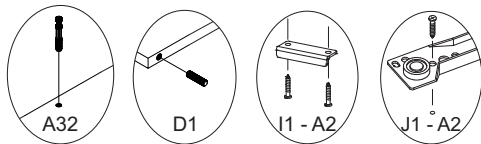
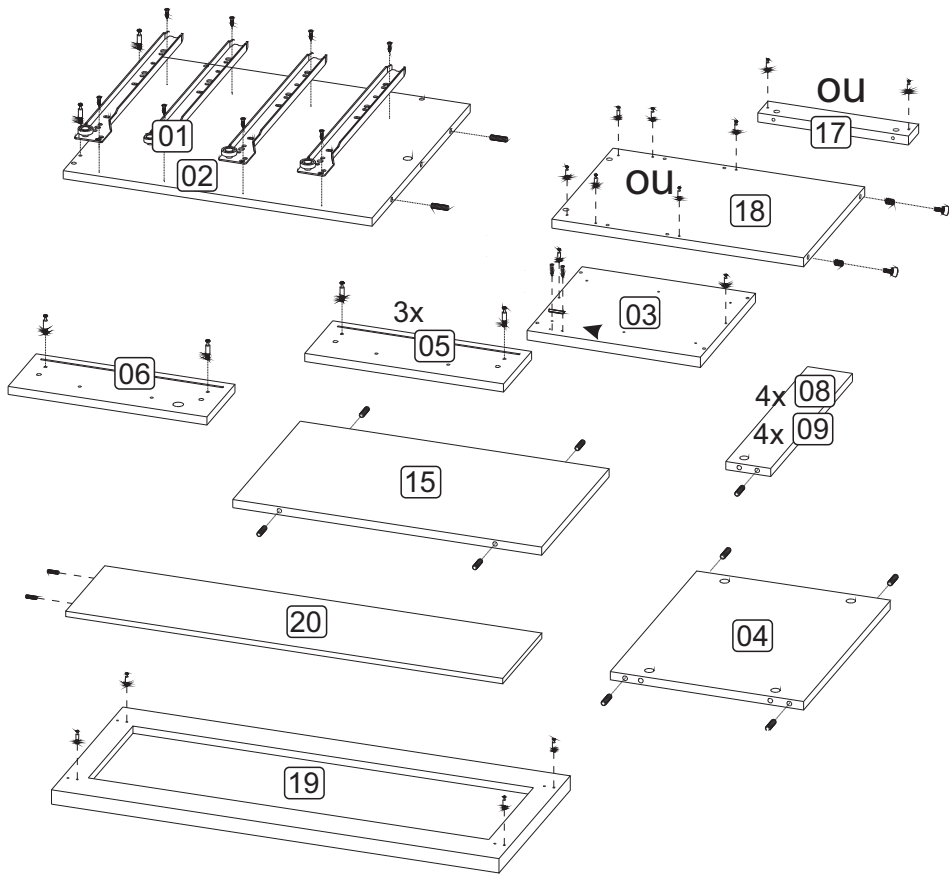

Repassar a Furação 05mm
Repasar la Perforacion
Repass to Hole



ou

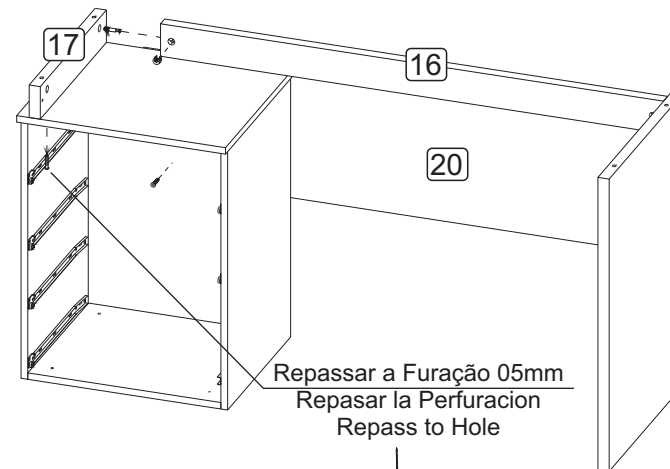

Repassar a Furação 05mm
Repasar la Perforacion
Repass to Hole

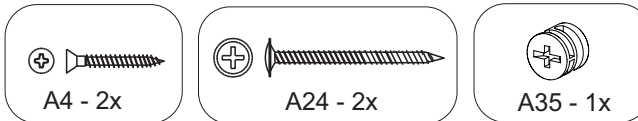

outras opções

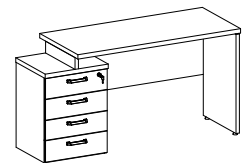
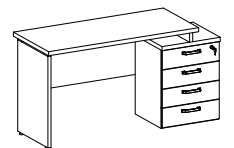
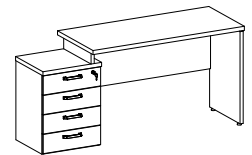
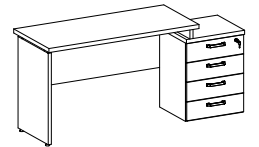

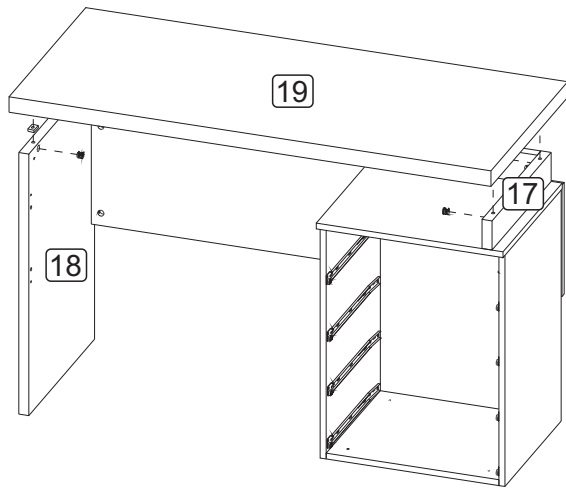

ou

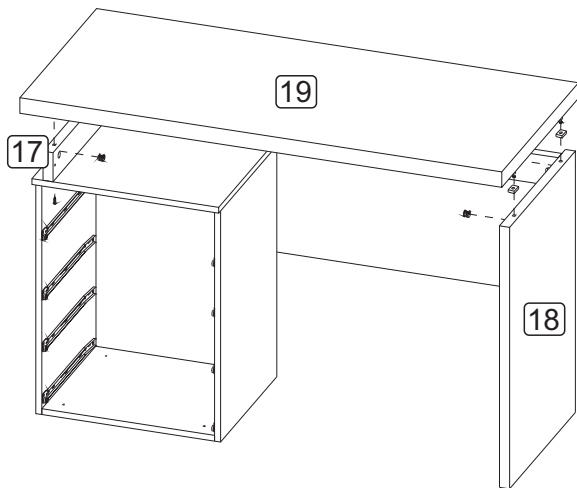

outras opções

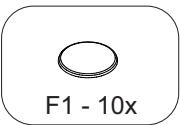
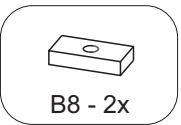
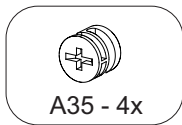
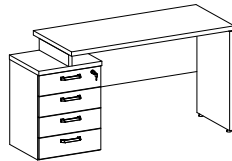
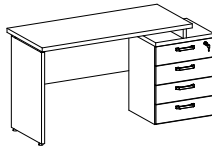
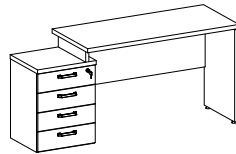
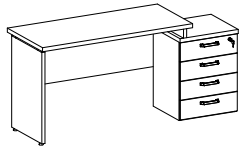

ACESSÓRIOS ACCESSORIES ACCESORIOS

A2 - PARAF. 3,5x14 CC
20x



A3 - PARAF. 3,5x20 CP
40x



A4 - PARAF. 3,5x25 CC
2x



A5 - PARAF. 3,5x25 CF
8x

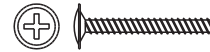

A24 - PARAF. 5,0x60 CF
2x



A32 - PARAF. MINIFIX
22x

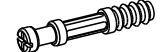

A35 - TAMBOR
MINIFIX **22x**



B2 - DISTANCIADOR
50x24x10 **2x**



C1 - PUXADOR
4x



D1 - CAVILHA 8x30
22x

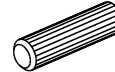

F1 - TAPA FURO ø18
18x



H6 - CANTONEIRA P/GAV
QUICK INSTALL **8x**



I1 - FECHADURA P/GAV.
1x



J1 - CORREDIÇA 350mm
4x

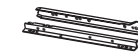

L2 - SAPATA PLAST. SEXT.
5/16 **2x**



L3 - SAPATA PLAST. 1/4
4x



L5 - BUCHA PLÁSTICA
P/SAPATA 5/16 **2x**



M2 - BATENTE P/PORTA
1x



M3 - CHAPA P/SAPATA
1/4" **4x**



B25 - SEPARADOR
P/ FECHADURA **1x**



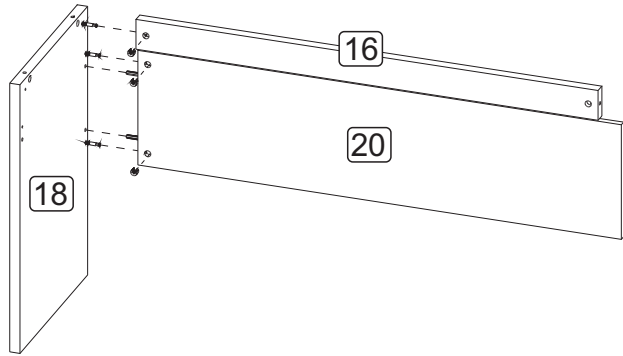

ou

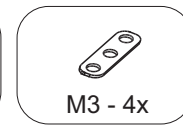
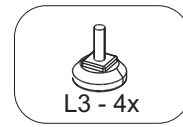
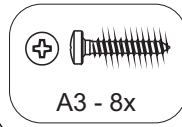
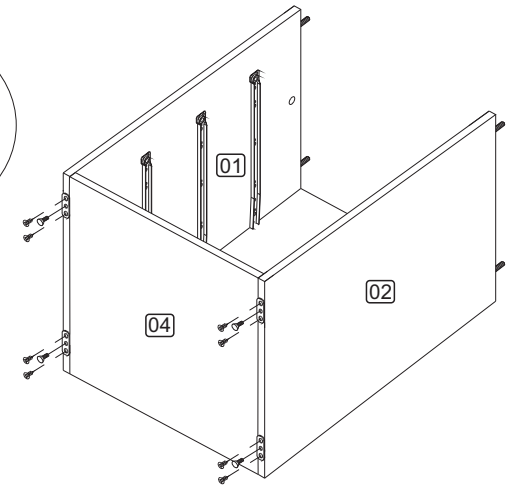
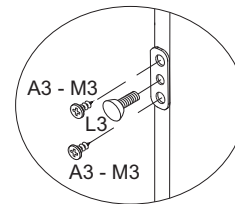
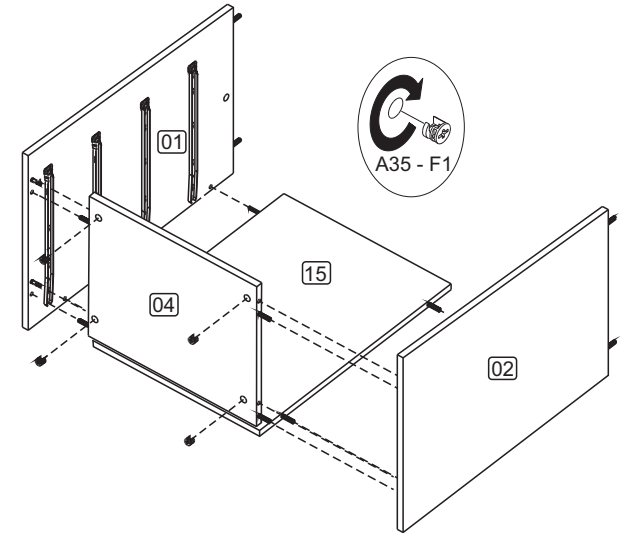
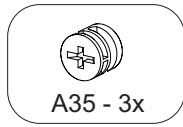
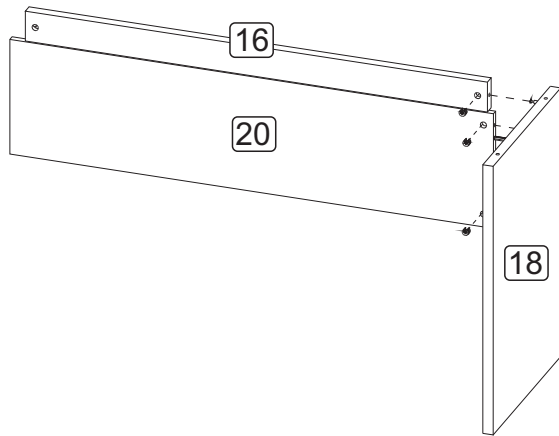

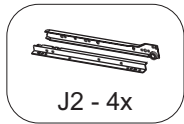
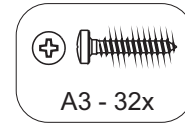
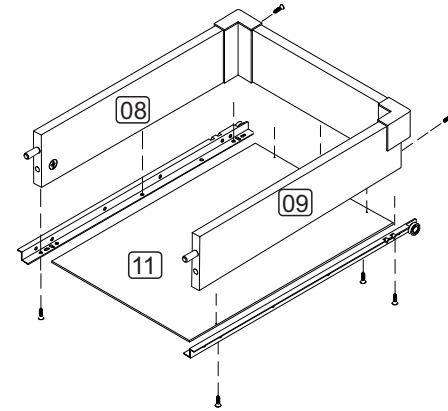
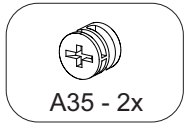
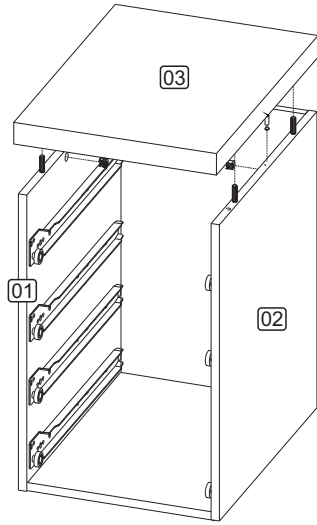

(4x)

