

Capacidade de Carga - Load Capacity - Capacidad de carga

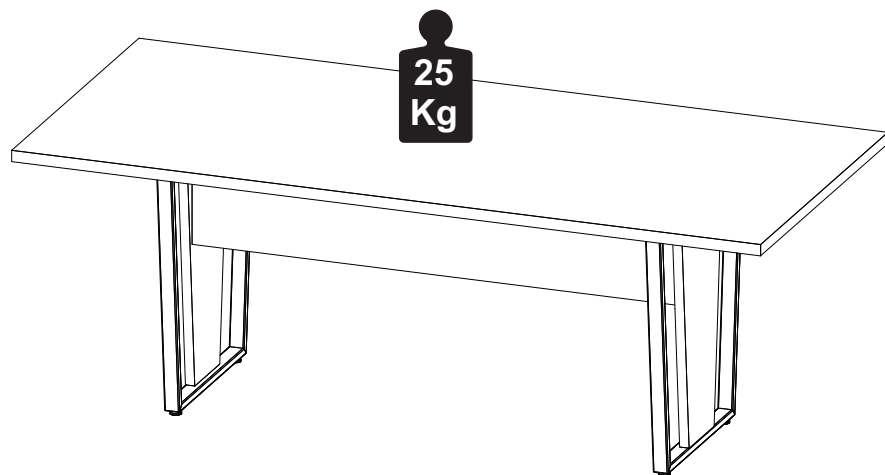

Manutenção e Limpeza

Vidros: pano levemente umedecido com álcool, seguido de pano seco.
Madeiras: pano levemente umedecido com água, seguido de pano seco.
*Nunca utilizar produtos químicos ou abrasivos.

Maintenance and Cleaning

Glasses: cloth lightly moistened with alcohol, followed by dry cloth.
Woods: cloth slightly moistened with water, followed by cloth seo.
*Never use chemicals or abrasives.

Mantenimiento y Limpieza

Vidrios: legeramente humedecido con alcohol, seguido de un paño seco.
Madera: ligeramente humedecido con agua, seguido de un paño seco.
*No utilice nunca productos quimicos o abrasivos.

08/08

INSTRUÇÕES DE MONTAGEM ASSEMBLY INSTRUCTIONS INSTRUCCIONES DE MONTAJE

MESA DE REUNIÃO CONFERENCE TABLE MESA DE CONFERENCIA

YAR2191

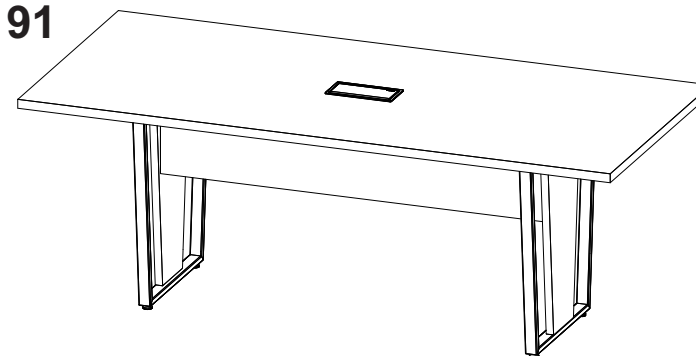

YAR2190

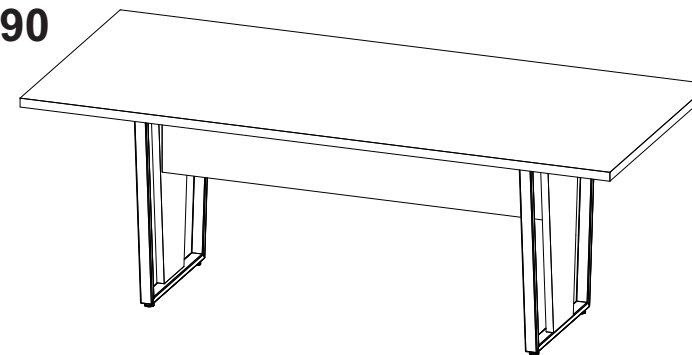

REF. #YAR2190-YAR2191



MOBILIÁRIO
PARA ESCRITÓRIO

GEBB Work Ind. de Móveis Ltda.
Rua Felix Roman, 190
São Valentin

95709-170 - Bento Gonçalves - RS - Brasil
Fone: (0XX54) 3454-1105 - (0XX54) 3453-1407
Phone: (0XX54) 3454-1105 - (0XX54) 3453-1407
E-mail: pedidos@gebbwork.com.br
www.gebbwork.com.br

WhatsApp: +55 54 99177-8324

REV.: 00 - 10/07/2023

01/08

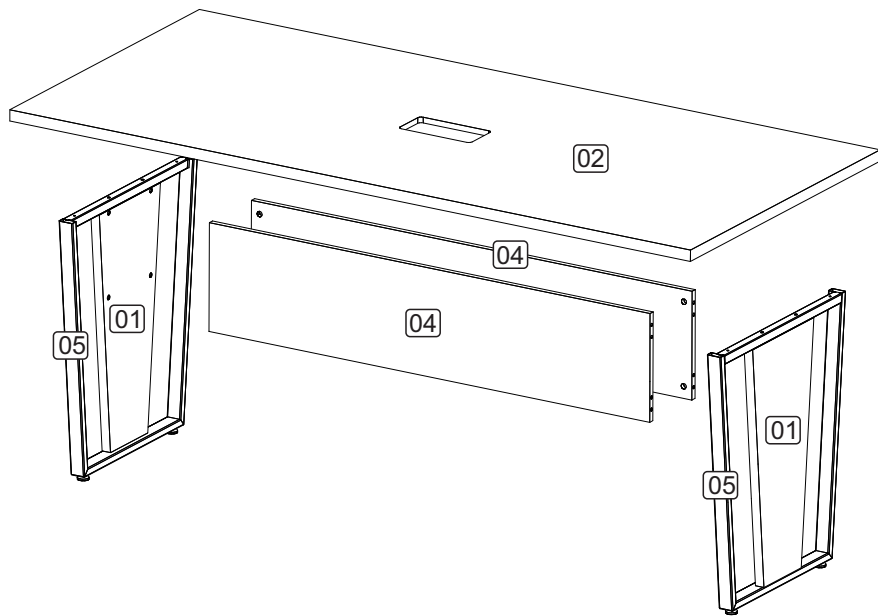

LISTA DE PEÇAS

- 01 - Aplique
- 02 - Tampo
- 04 - Painel Frontal
- 05 - Pé Metálico

LISTA DE PIEZAS

- 01 - Marco lateral
- 02 - Tapa
- 04 - Panel Delantero
- 05 - Lateral Metálica

PARTS IDENTIFICATION

- 01 - Side frame
- 02 - Top
- 04 - Front Panel
- 05 - Metallic Side

4

POSICIONAMENTO DO TAMPO POSICIONAMIENTO DE LA TAPA

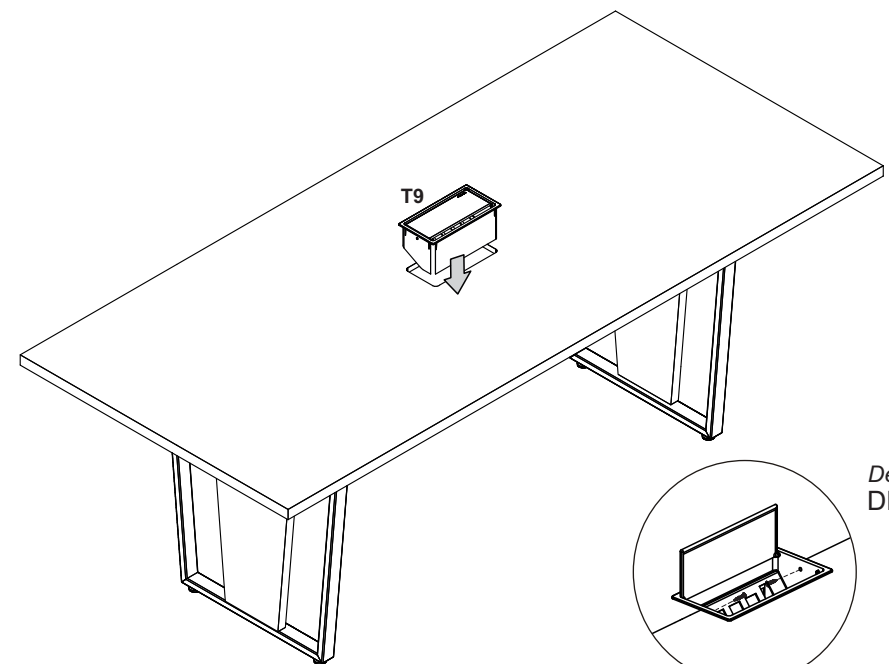
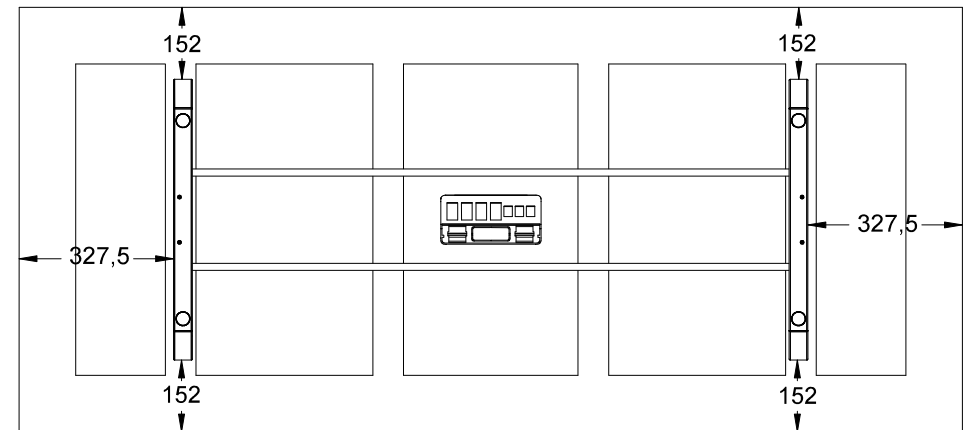

Detalle / Detail
DETALHE 1







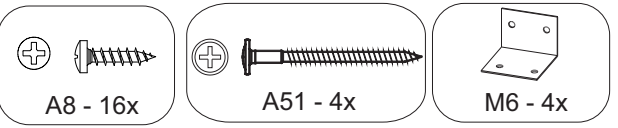
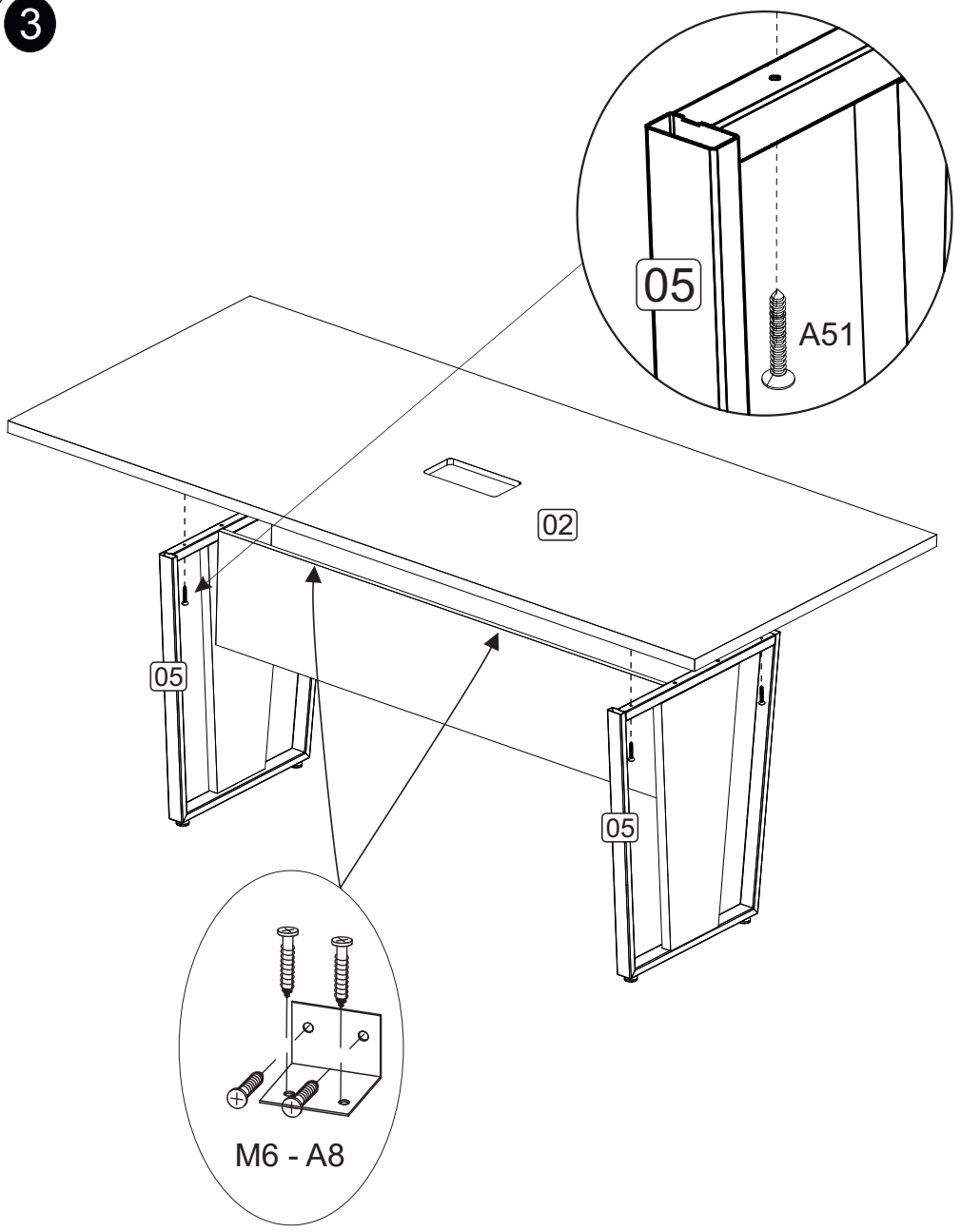

Somente no item YAR2191
Just no item YAR2191

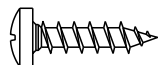
Ver manual de montagem da caixa.
Consulte el manual de montaje de la caja.
See box assembly manual.

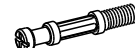
3



ACESSÓRIOS ACCESSORIES ACCESORIOS

- | | | |
|---|--|---|
| A8 - PARAF. 4,0x14 CP
16x
 | A51 - PARAF. 4,0x35 CF
4x
 | A15 - PARAF. 4,0x40 CP
8x
 |
| A29 - PARAF. MINIFIX
M6x33m 8x
 | A35 - TAMBOR
MINIFIX 8x
 | A36 - BUCHA M6x33
8x
 |
| M6 - CANTONEIRA L
04 FUROS 4x
 | L2 - SAPATA PLAST.
SEXT. 4x
 | L5 - BUCHA PLÁSTICA
P/SAPATA 5/16 4x
 |

1 PRÉ-MONTAGEM

Preasamblea
Pre-assembly

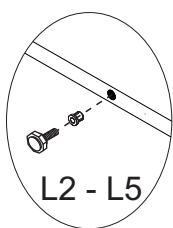
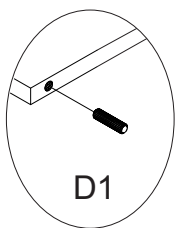
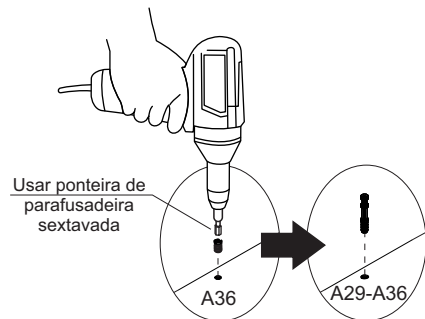
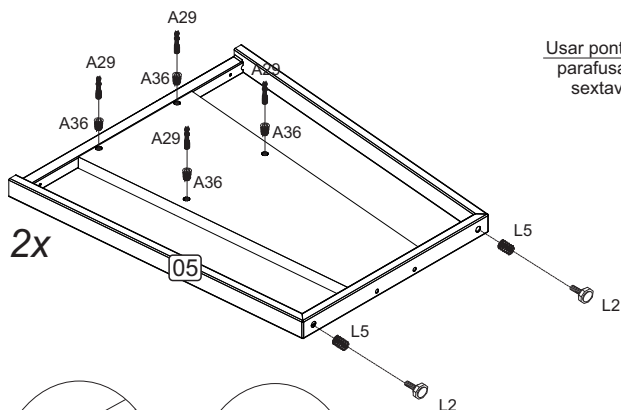
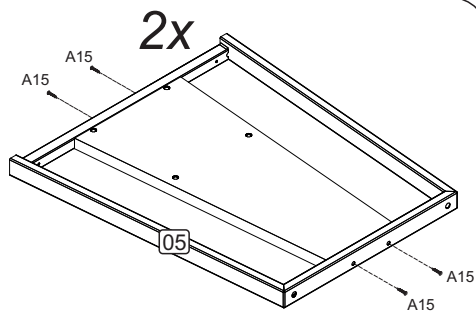
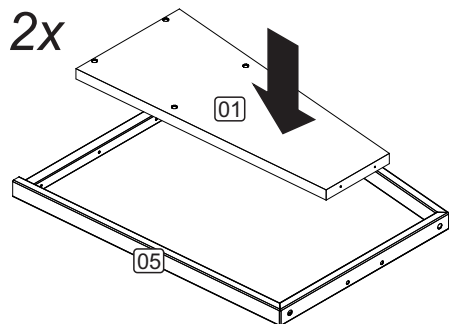

04/08

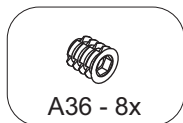

A36 - 8x

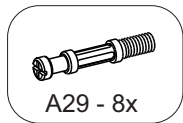

A29 - 8x

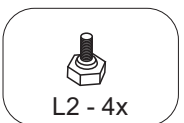

L2 - 4x

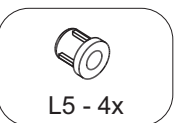

L5 - 4x

2 MONTAGEM

Armado
Assembly

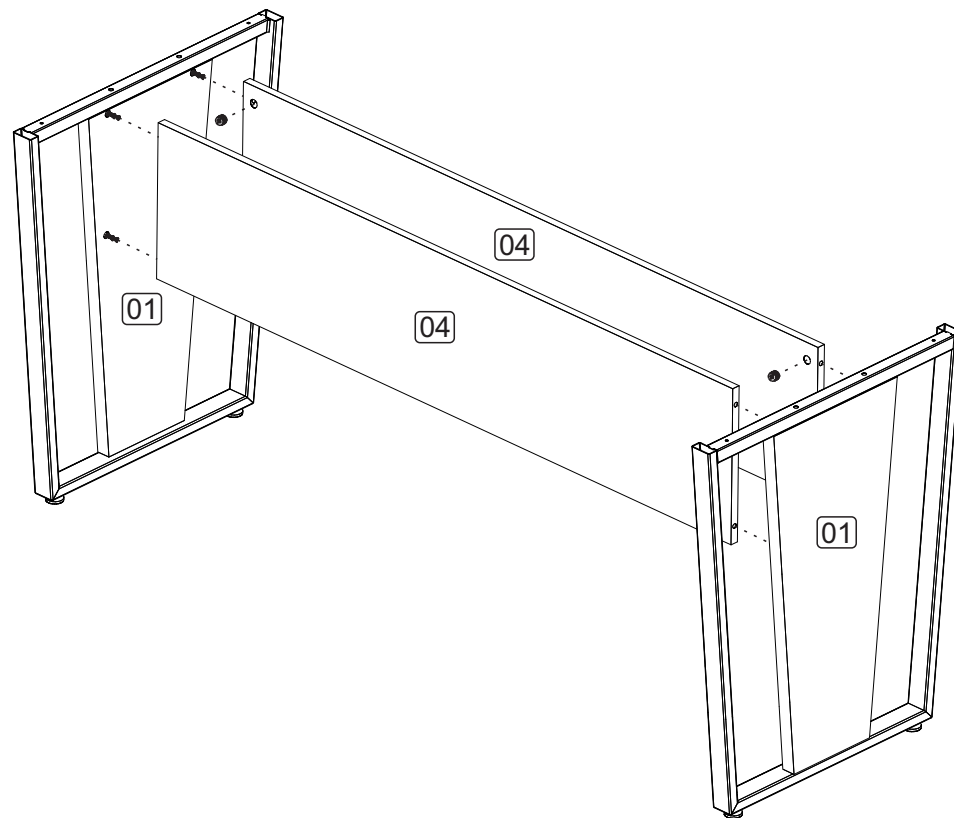

Depois de encaixar as peças coloque o tambor com a sua seta voltada para o parafuso. Para apertar Gire no sentido horário.
Después de colocar las piezas, coloque el tambor con su flecha hacia el tornillo. Para apretar, gire en sentido horario.
After fitting the parts, place the drum with its arrow facing the screw. To tighten, turn clockwise.

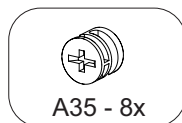
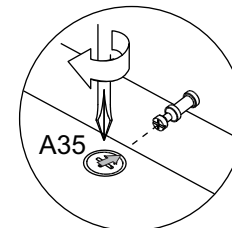

A35 - 8x

05/08